



*Delayed Lenz's Law,  
Electrical Power Generation,  
Flying (cigar shaped) Resonant Cavity,  
Transmitting through Faraday Cages*

*The Theories of George J Bugh*

*(Updated July 15, 2016 to fix slide formatting errors)*

This presentation and text from it may be copied if  
the Vasant Corporation copyright notice is included.

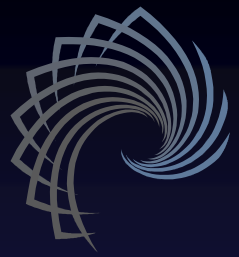

## *The Purpose of this Presentation is to Explain:*

- That Lenz's Law is meant to be applicable in situations where the source of EMF and the source of CEMF are much less than 1 wavelength apart.
- The affects when the distance between EMF and CEMF sources approach  $\frac{1}{4}$  wavelength.
- The affects within an ellipsoidal resonant cavity between a source of EMF from 1 foci and a source of CEMF from the other foci.
- What happens when a ferromagnetic material is the source of CEMF at the 2nd foci within an ellipsoidal resonant cavity.

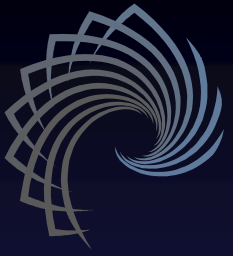

# *Definitions:*

- The first series of slides will review applicable terms:
  - EMF and Counter (back) EMF
  - Lenz's Law
  - Conservation of Energy
  - Wavelength *lambda* ( $\lambda$ )

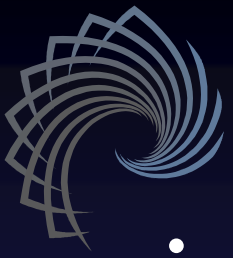

# *EMF and CEMF*

- From Wikipedia, (The definitions are long so I'm truncating to the parts applicable to the following slides.):

## **EMF:**

“Electromotive force, also called EMF, (... measured in volts), refers to voltage generated ... by the magnetic force according to Faraday's Law, which states that a time varying magnetic field will induce an electric current.... Electromotive "force" is not considered a force, as force is measured in newtons, but a potential, or energy per unit of charge, measured in volts. ...”

## **CEMF:**

“Counter-electromotive force also known as back electromotive force (abbreviated counter EMF, or CEMF)[1] is the voltage, or electromotive force, that pushes against the current which induces it. CEMF is caused by a changing electromagnetic field. It is the effect of Lenz's Law of electromagnetism. ...”

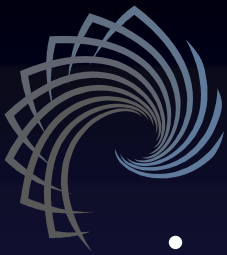

## *Example of EMF and CEMF*

- If an AC voltage is applied to the primary winding of a transformer it causes a current flow and this creates a magnetic field that expands out from the primary winding and expands through the secondary winding.
- The magnetic field expanding creates an EMF in the secondary that causes current to flow in the secondary if it is connected to a load so as to complete a circuit current path.
- The current flows in the opposite direction of the primary current.
- This creates a magnetic field of its own with an orientation that opposes the magnetic field of the primary winding. It expands through the primary winding and creates a CEMF voltage potential in the primary winding.
- This causes a current flow that is opposite to the secondary current and so is in the same direction the primary current is flowing already.
- So a shorted secondary causes much primary current.

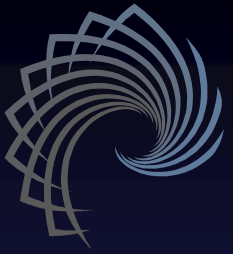

# Lenz's Law

- From Wikipedia:

“Lenz's law /'ləntsɪz lɔː/ is a common way of understanding how electromagnetic circuits obey [Newton's third law](#) and the [conservation of energy](#).<sup>[1]</sup> Lenz's law is named after [Heinrich Lenz](#), and it says:

*An induced [electromotive force](#) (emf) **always** gives rise to a current whose magnetic field opposes the original change in [magnetic flux](#).”*

- As will be discussed in this presentation, the use of the word: “**always**” is only appropriate with the unspoken assumption that the source of EMF and the source of CEMF are much less than 1 wavelength apart from each other.

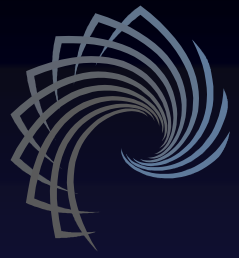

# Lenz's Law and a Dynamo

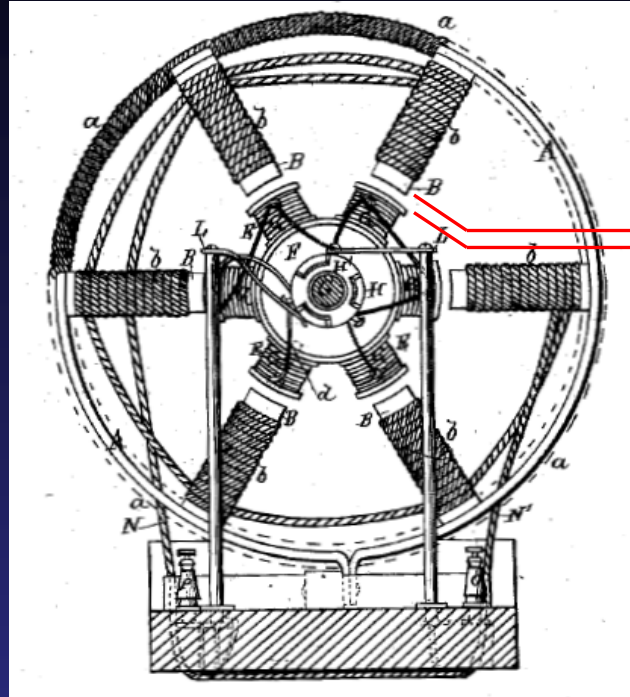

This gap width is much less than 1 wavelength of the AC signal to or from the dynamo.

- When the magnetized rotor is mechanically rotated, it induces a current in the stator if the stator is connected to an electrical load to complete a circuit.
- The stator's induced current causes a magnetic field that radiates back to the rotor and pushes against the rotor's magnetic field, requiring continuous mechanical force to push back against it to keep turning the rotor.
- Aside from friction losses, eddy current losses, etc., the electrical energy transferred from the stator to an electrical load equals the mechanical energy required to turn the rotor, so energy is conserved.

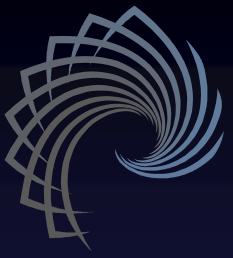

# Conservation of Energy

- From Wikipedia:

“The total energy is said to be *conserved* over time. For an isolated system, this law means that energy can change its location within the system, and that it can change form within the system, for instance [chemical energy](#) can become [kinetic energy](#), but that energy can be neither created nor destroyed. ... *matter* particles (such as electrons) can be converted to *non-matter* (such as [photons](#) of [electromagnetic radiation](#)), or even into potential energy or kinetic energy. Matter could also be created out of kinetic or other types of energy, in the process of [matter creation](#). ... A consequence of the law of conservation of energy is that no intended "[perpetual motion machine](#)" can perpetually deliver energy to its surroundings.<sup>[2]</sup>”

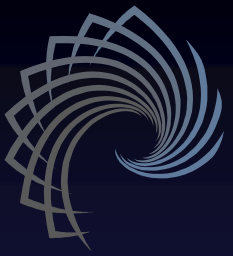

# *Conservation of Energy* continued

- An apparent perpetual motion machine must always be transferring energy from some source.
- That source could, for example, be matter converted to energy through some known or unknown process.
- That source could, for example, be some electromagnetic energy received from some unknown source.
- By these statements this author is not discounting “free energy” machines.
- Unknown sources and energy transfer processes are possible.
- Economically “free energy” is possible but the law of conservation of energy is never violated.

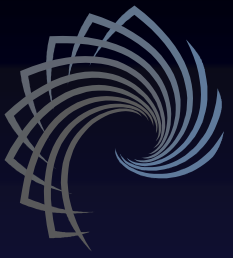

# Wavelength lambda ( $\lambda$ )

- From Wikipedia:

“In physics, the wavelength of a sinusoidal wave is the spatial period of the wave, the distance over which the wave's shape repeats.<sup>[1]</sup> It is usually determined by considering the distance between consecutive corresponding points of the same phase, such as crests, troughs, or zero crossings, and is a characteristic of both traveling waves and standing waves, as well as other spatial wave patterns.<sup>[2][3]</sup> Wavelength is commonly designated by the Greek letter lambda ( $\lambda$ ). ... Assuming a sinusoidal wave moving at a fixed wave speed, wavelength is inversely proportional to frequency: waves with higher frequencies have shorter wavelengths, and lower frequencies have longer wavelengths.<sup>[6]</sup>”

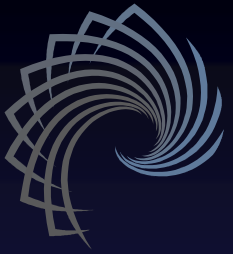

## *When should Lenz's Law apply?*

- The next series of slides discuss when it is appropriate to adhere to Lenz's Law and when it is not.
- NOTE: In diagrams to follow a blue arrow is used to indicate electron current flow (negative charges) rather than the flow of positive charges.

# Lenz's Law with small gap widths

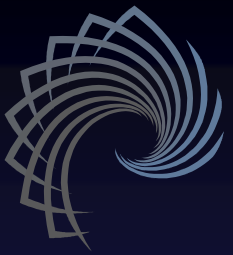

Magloop antenna with a circumference of less than or equal to  $\lambda/10$

- The Magloop antenna is similar to and used to represent a 1 turn primary of a transformer or a 1 turn rotor winding of a dynamo.
- The thick copper plate is similar to and used to represent a 1 turn transformer secondary that is shorted or a 1 turn stator that is shorted.
- Consider when the GAP WIDTH is, for example, less than  $\lambda/100$  as would be the case with typical transformers and dynamos (motor/generators).
- An AC signal generator connected through a transmission line and an impedance matching network (all not shown), causes electron current flow (blue arrow) in the magloop antenna.
- The magloop antenna's electron current flow creates a magnetic field that radiates out to the thick copper plate. It is really an electromagnetic field but the radiated electric field component is small from this type of antenna.

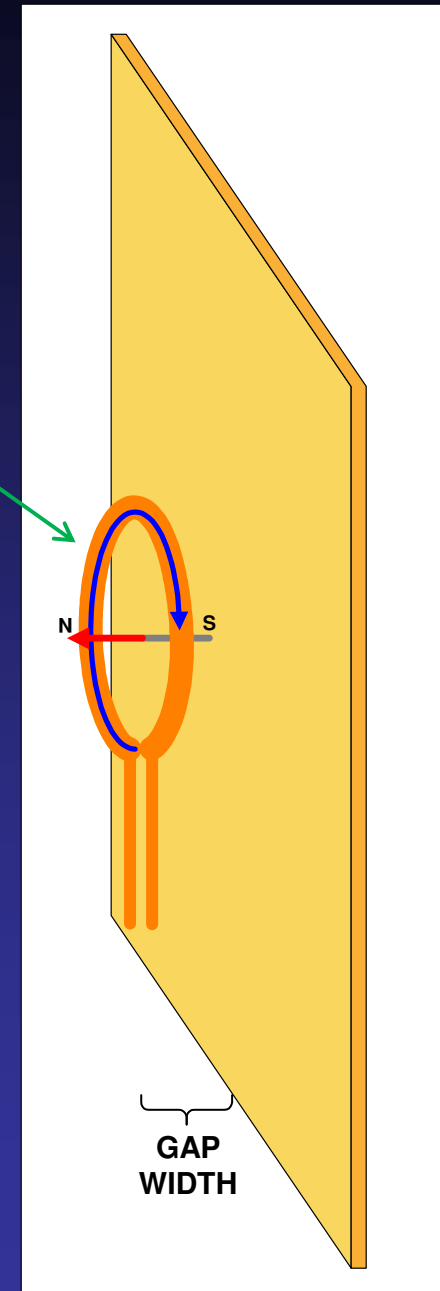

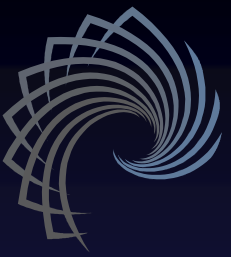

# Lenz's Law with small gap widths *continued*

The current flow induced by the reflected SOUTH flux cutting through the magloop antenna adds to current induced by the signal generator's voltage.

Induced current flow

- When this magnetic field reaches the copper plate, it creates an EMF voltage within the copper plate that generates electron current flow (blue arrow) in the copper plate in the opposite direction to the electron current flow in the magloop antenna.
- The copper plate's current flow generates a magnetic field that radiates back towards the magloop antenna's magnetic field and pushes against this magnetic field of the magloop antenna.
- The magnetic field from the copper plate also creates a CEMF voltage in the magloop antenna.
- This CEMF induces current in the magloop antenna in the same direction it is flowing already thus increasing its total current flow and so transfers the affect of the shorted secondary back to the signal source and loads down the signal generator.
- The transfer of the "shorted" condition of the secondary (copper plate) back to the primary (magloop antenna) is all in keeping with the law of conservation of energy.
- In this example, Lenz's Law **does** apply.

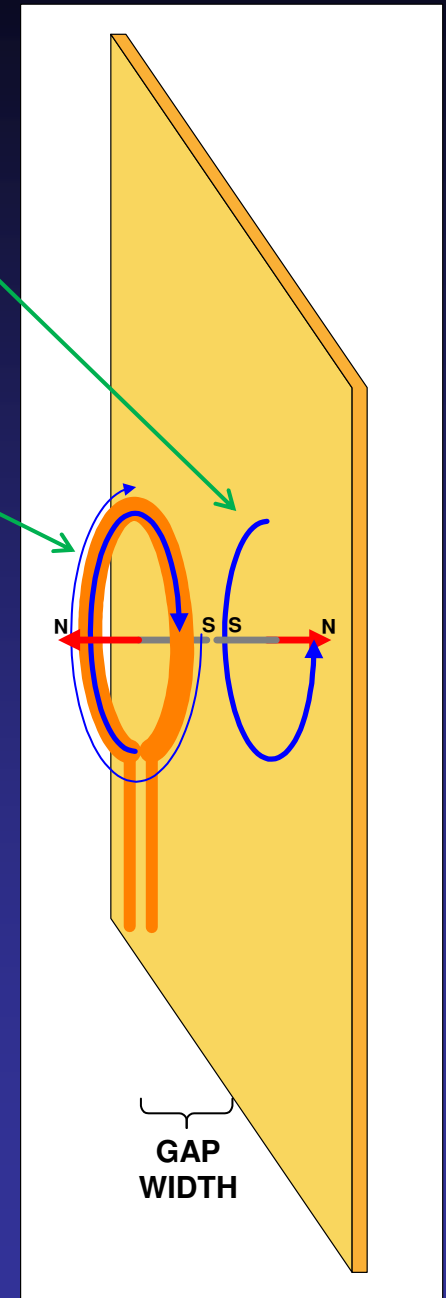

# Lenz's Law with large gap widths

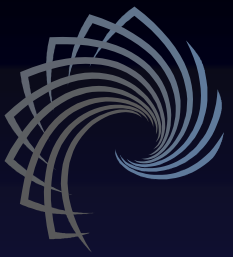

- Now consider when the GAP WIDTH is  $\lambda/4$ .
- The magloop antenna and the copper plate are only partially coupled due to the greater distance between them and the plate being flat doesn't focus its reflected signal on the magloop antenna.
- The total delay before a CEMF is generated in the magloop antenna will then be  $\lambda/2$ . In addition, the act of reflecting off the copper plate also creates a  $\lambda/2$  phase shift. This is the effect of the copper plate's current being in the opposite direction from the current in the magloop.
- As shown on the next slide, the electromagnetic field from the copper plate, by the time it reaches the magloop antenna, is in phase with the electromagnetic field radiating from the magloop antenna at that time.
- The CEMF generated in the magloop antenna induces current flow in the opposite direction to the magloop antenna's current flow that the signal generator is creating at the time the CEMF occurs.

Induced current flow

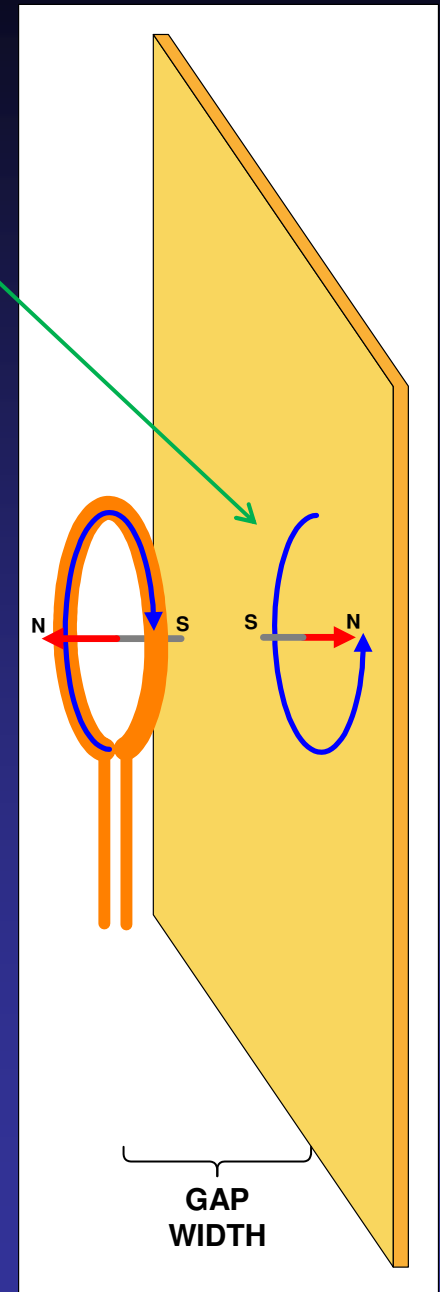

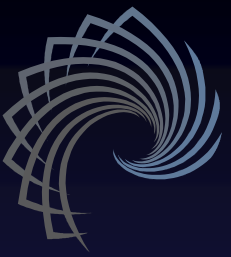

# Lenz's Law with large gap widths *continued*

The current flow induced by the reflected SOUTH flux cutting through the magloop antenna reduces current induced by the signal generator voltage.

Induced current flow

- This CEMF counter acts and so reduces the current in the magloop antenna and so this is reducing the loading on the signal generator rather than increasing the loading on the signal generator.
- The reflected electromagnetic field from the copper plate continues on through the magloop antenna and radiates out into space along with the in phase electromagnetic field radiating from the magloop antenna.
- The 2 magnetic fields pull on each other rather than push each other.
- This is a typical configuration of many directional antenna designs.
- However, most of the electromagnetic energy is radiated out into space and so will not be doing much useful work locally.
- In this example, Lenz's Law **does not** apply.

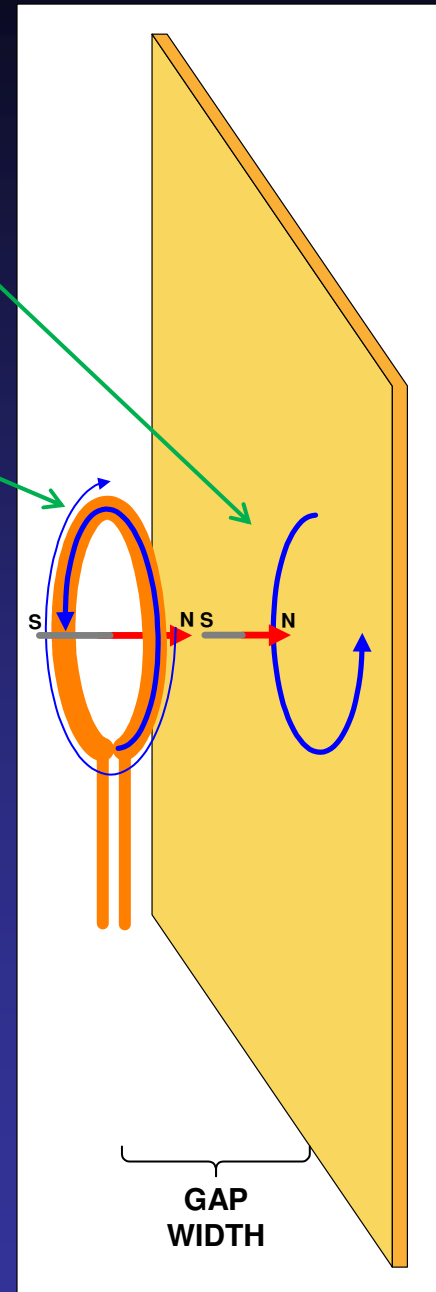

# *Containing and using the EM radiation*

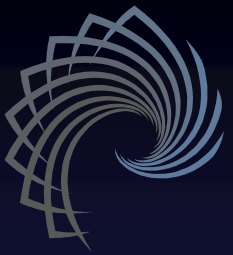

- So, what if we stop the electromagnetic fields from radiating away?
- What if we reflect them back to the source after an optimum amount of delay and analyze what happens?
- We can do that with an ellipsoidal cavity which has 2 foci.

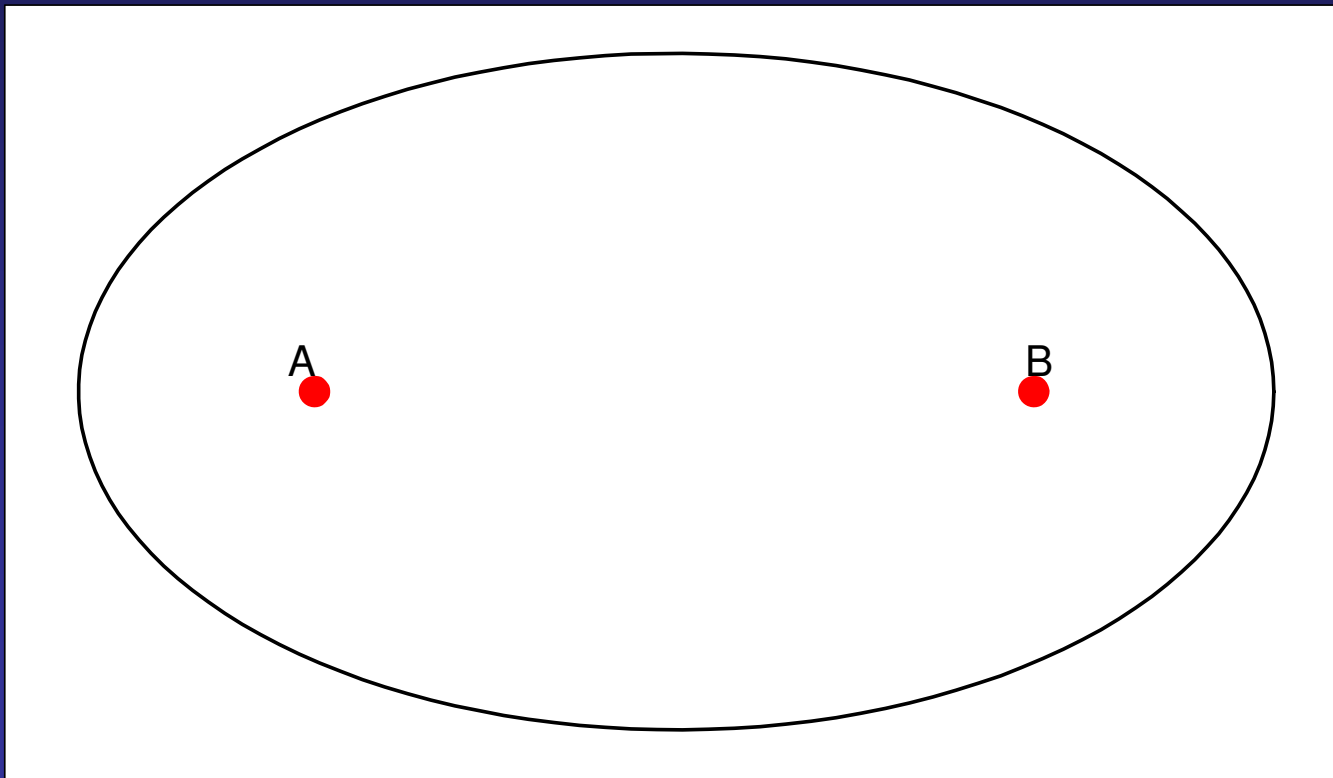

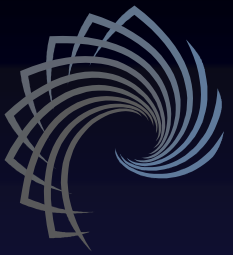

# An Ellipsoidal Cavity

- Radiation from an antenna at foci A, when reflecting off any part of the inner surface, will reach an object at foci B after traversing the same total distance traveled by any other reflected radiation regardless of the reflected path, so all reflected radiation reaches foci B in phase with all other portions of reflected radiation, as demonstrated in the following equation:

$$\overline{AC_0} + \overline{BC_0} = \overline{AC_1} + \overline{BC_1} = \overline{AC_2} + \overline{BC_2}$$

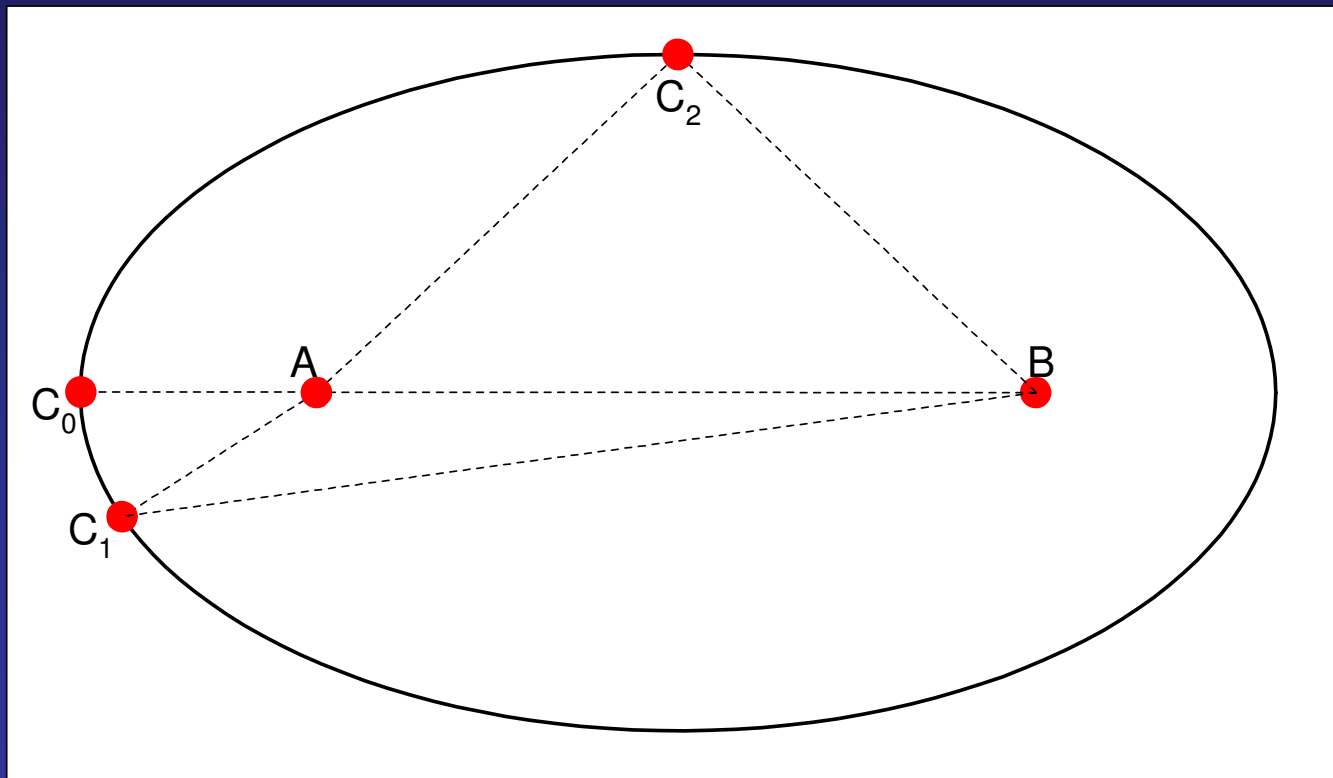

# Design Criteria for the Ellipsoidal Cavity

- A signal radiated from either foci to its respective nearest wall should reflect back from the nearest point on each wall so as to be in phase with each respective foci's signal at the time of its return, similar to antenna designs with a reflector spaced  $\lambda/4$  from the driven antenna element. This provides the lowest loading of a signal source at each foci. So the length A to  $C_0$  must be  $m\lambda + \lambda/4$  where "m" is either zero or increments of 1/2, for a total phase shift to the nearest wall and back of  $0.5\lambda$  or  $1.5\lambda$  or  $2.5\lambda$ , etc.. Keep in mind that by reflecting off the wall, the signal experiences another  $\lambda/2$  phase shift (mirror image) and this is what causes the signal to be in phase with the signal at each nearest foci when it arrives back at each foci.

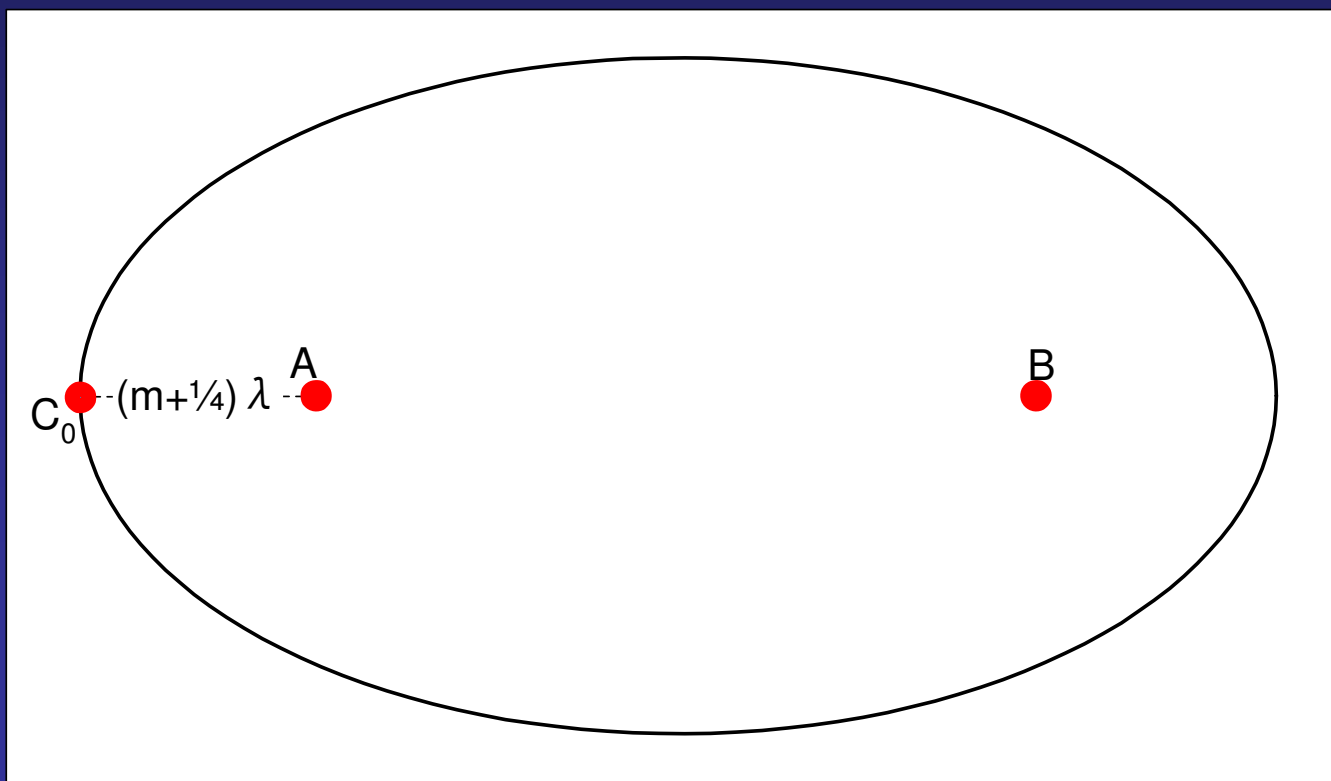



# *Design Criteria for the Ellipsoidal Cavity*

*continued*

- All direct path signals from A to B must arrive after some number of half wavelengths plus a  $\lambda/4$  additional phase shift so that when its reflection off B returns to A by a direct path, it arrives at A with a total delay of some number of wavelengths plus an additional  $1/2\lambda$  phase shift so as to be in phase with the signal at A when it arrives. So the length A to B must be  $n\lambda + \lambda/4$  where “n” is either zero or increments of  $1/2$ , for a total phase shift of  $0.5\lambda$ ,  $1.5\lambda$ ,  $2.5\lambda$ , etc..

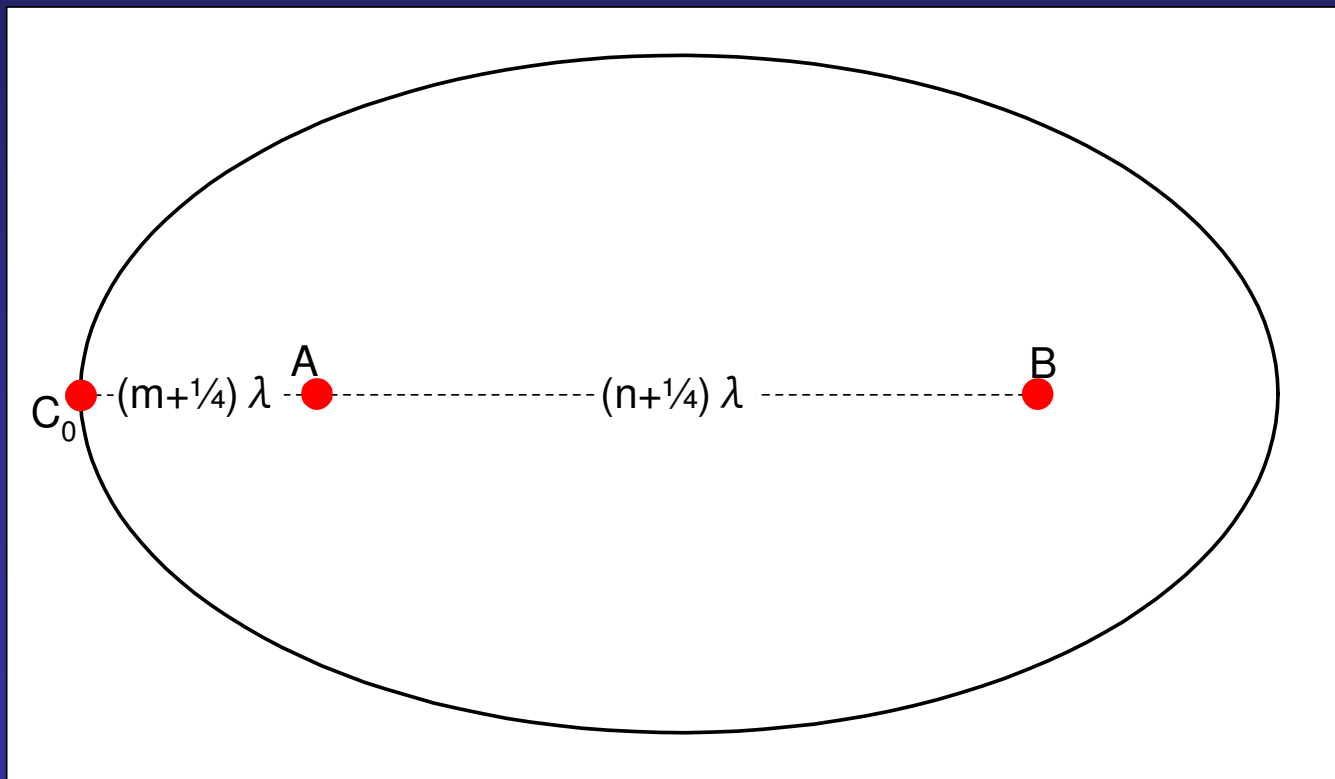

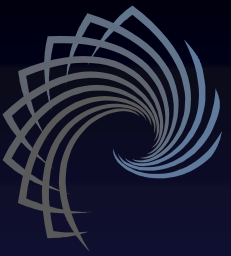

# Design Criteria for the Ellipsoidal Cavity

*continued*

- The total distance of a signal from A to  $C_0$  and then from  $C_0$  to B will be:  
Total distance =  $(m + 1/4)\lambda + ((m + 1/4)\lambda + (n + 1/4)\lambda) = (2m + 1/2)\lambda + (n + 1/4)\lambda$   
or Total distance =  $(2m + 1/2 + n + 1/4)\lambda = (2m + n + 3/4)\lambda$
- The distance from either A or B to the equal distance point  $C_2$  will be half the Total distance so:  
A to  $C_2 = C_2$  to B =  $(2m + n + 3/4)\lambda/2 = (m + n/2 + 3/8)\lambda$

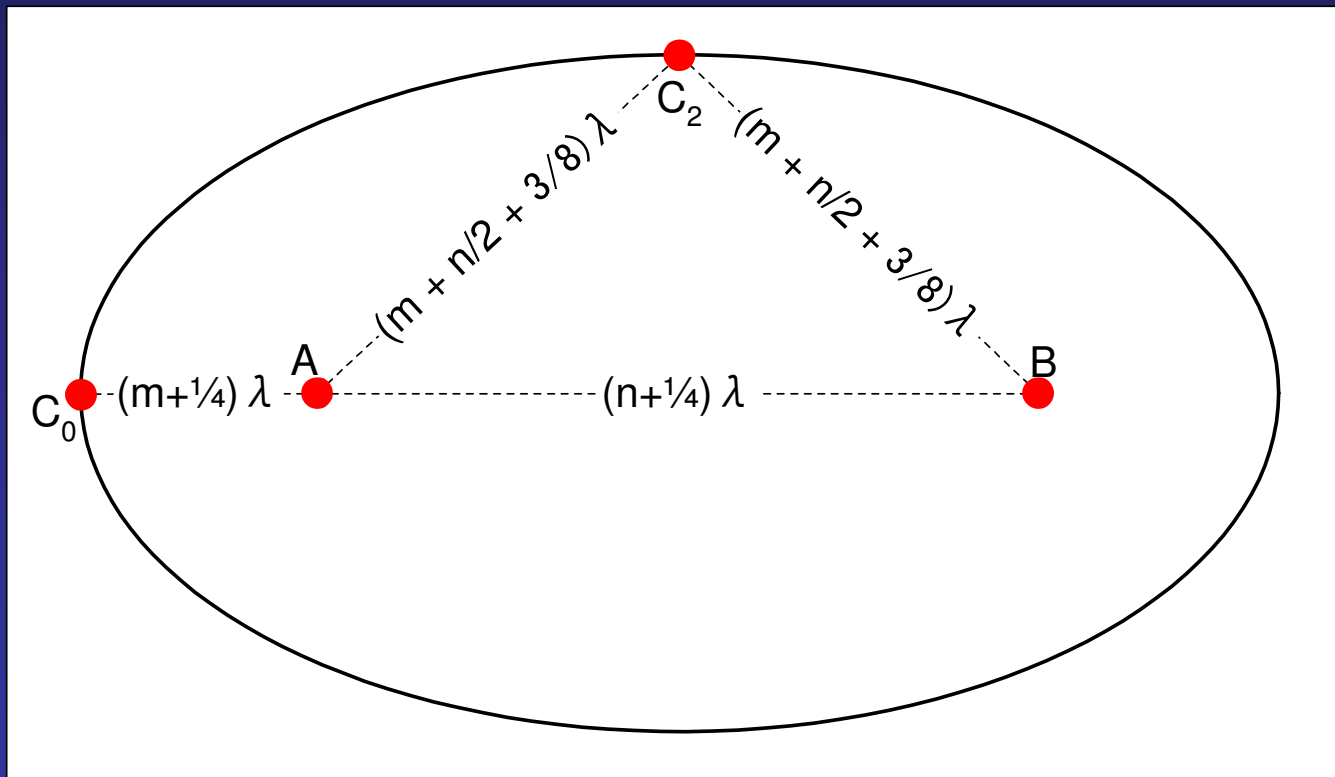

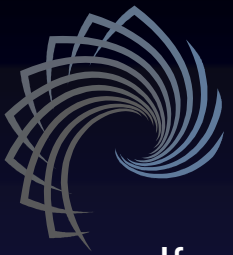

# Example Ellipsoidal Cavity

- If  $m$  and  $n$  are both set to zero for the smallest possible ellipsoid for a given wavelength, then the ellipsoid cross section dimensions will be as shown below.

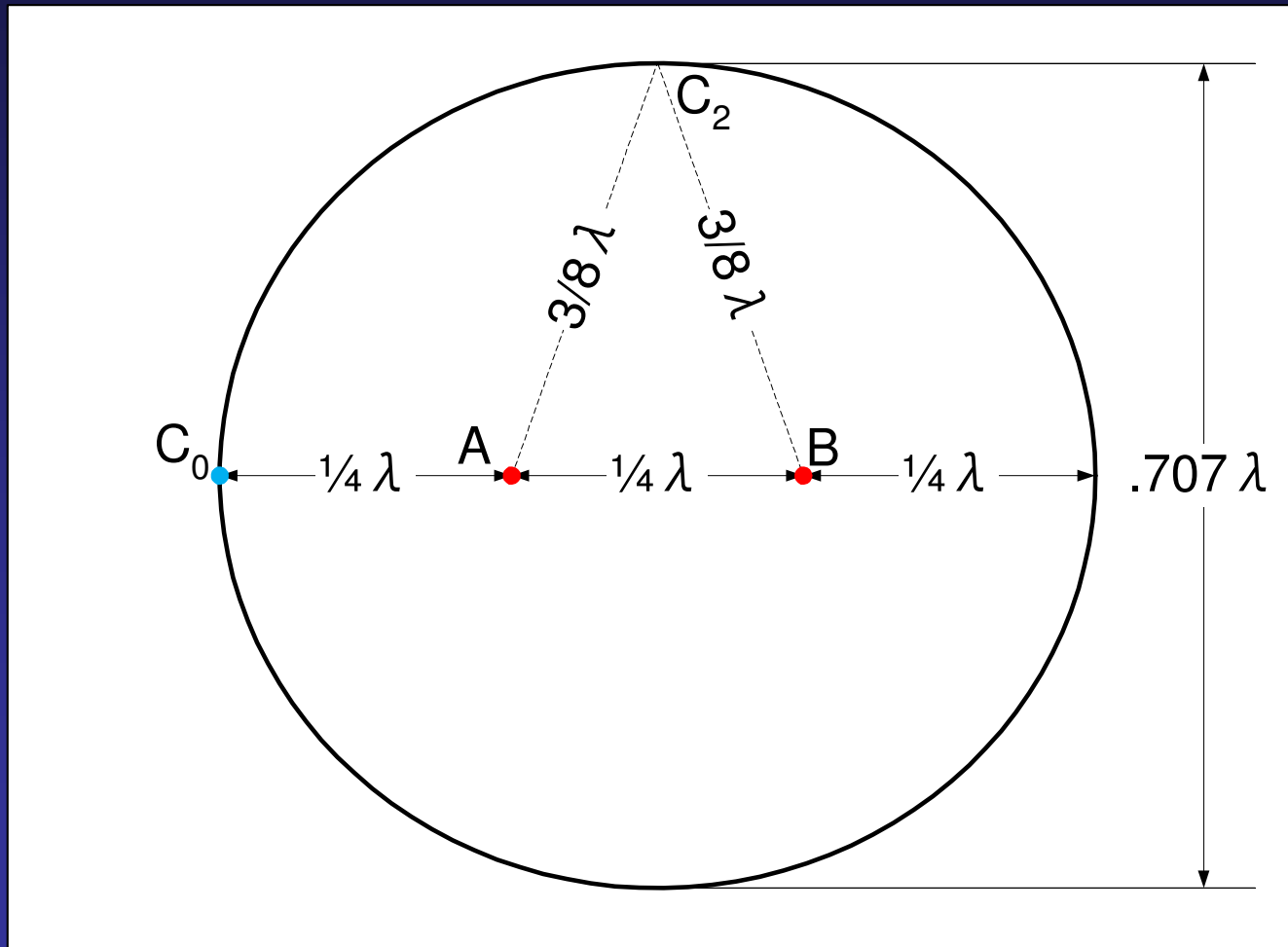

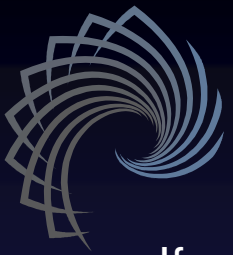

# Effects of a Reflected load

- If we use a magloop antenna (primary) at A as a source of a sinusoidal EM wave that has a wavelength  $\lambda$ , and we connect a load to a signal receiving antenna (secondary) at B, then the effects will be different than when they are much less than 1 wavelength apart. Things will not behave per Lenz's Law.

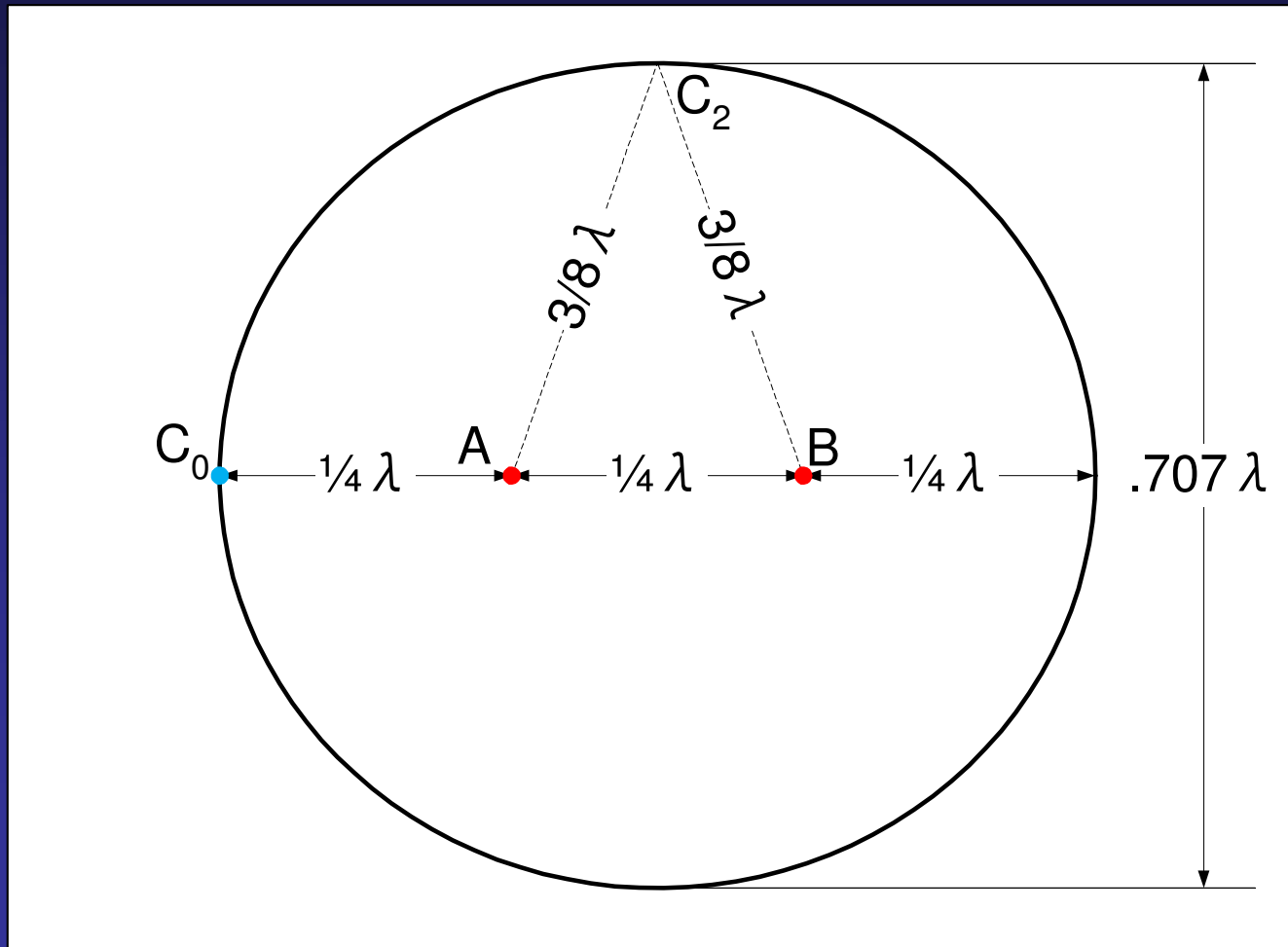

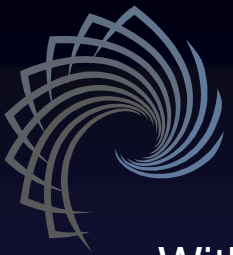

# Shorts become Opens

- With a magloop antenna at B connected to a value of capacitor that creates a tuned tank, then the high tank current reflects a large signal back to A with a  $180^\circ$  phase shift, plus the phase shift from the time delay, plus a  $180^\circ$  phase shift each time it reflects off an inner wall. The return signal arrives at A with a total phase shift that minimizes the loading on the magloop antenna at A rather than maximizing the loading.

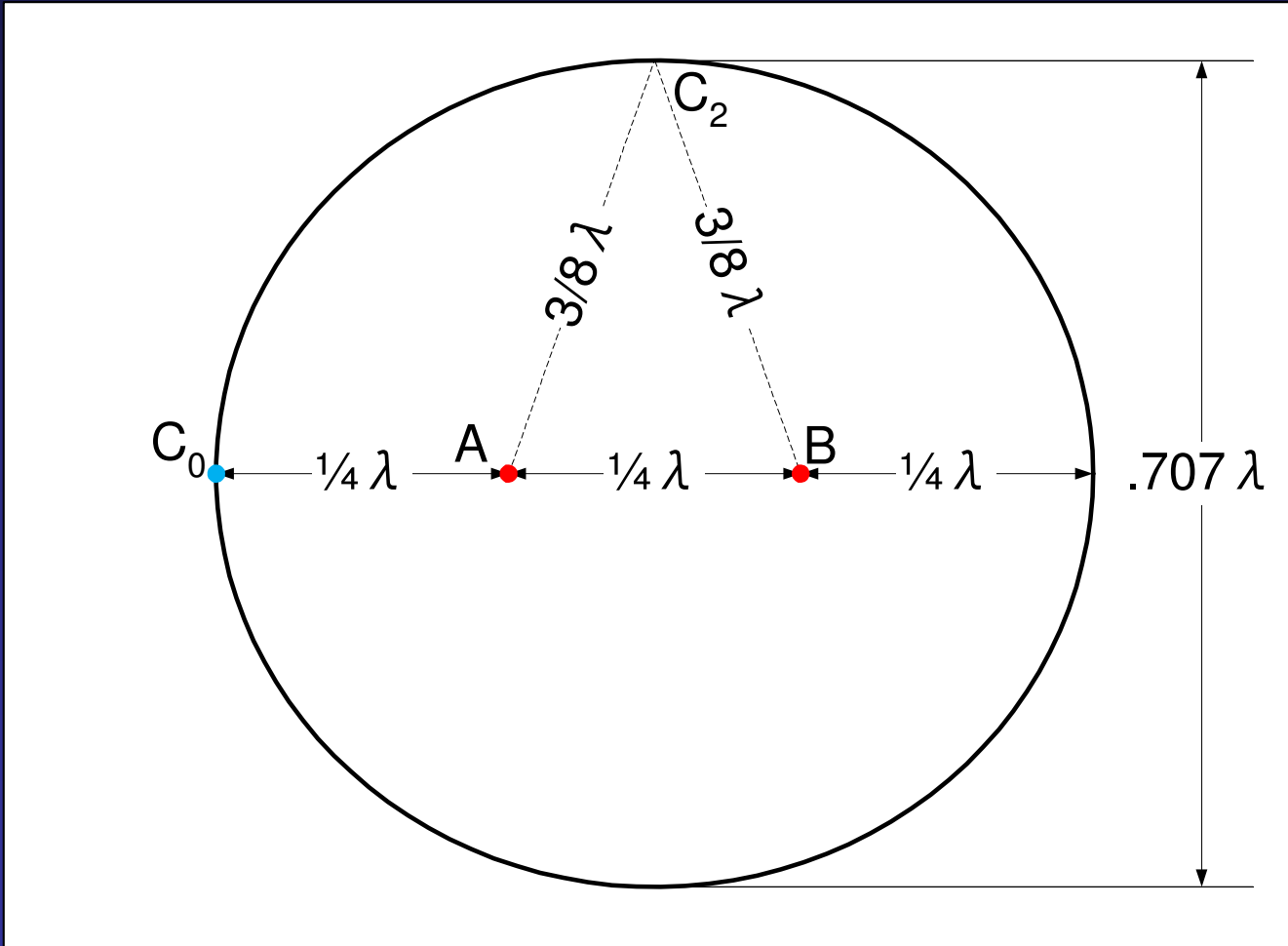

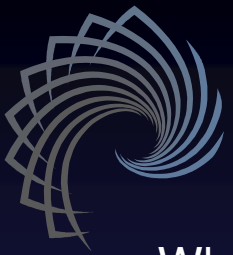

# Opens become Shorts

- When nothing is placed at B, when it is an open circuit, then the signal from A, reflecting off the inner walls and converging on B, will pass through B and go back to A. Since the signal does not experience a  $180^\circ$  phase shift from reflecting off anything at B, the signal will arrive at A at a phase that causes maximum current in the magloop antenna at A.

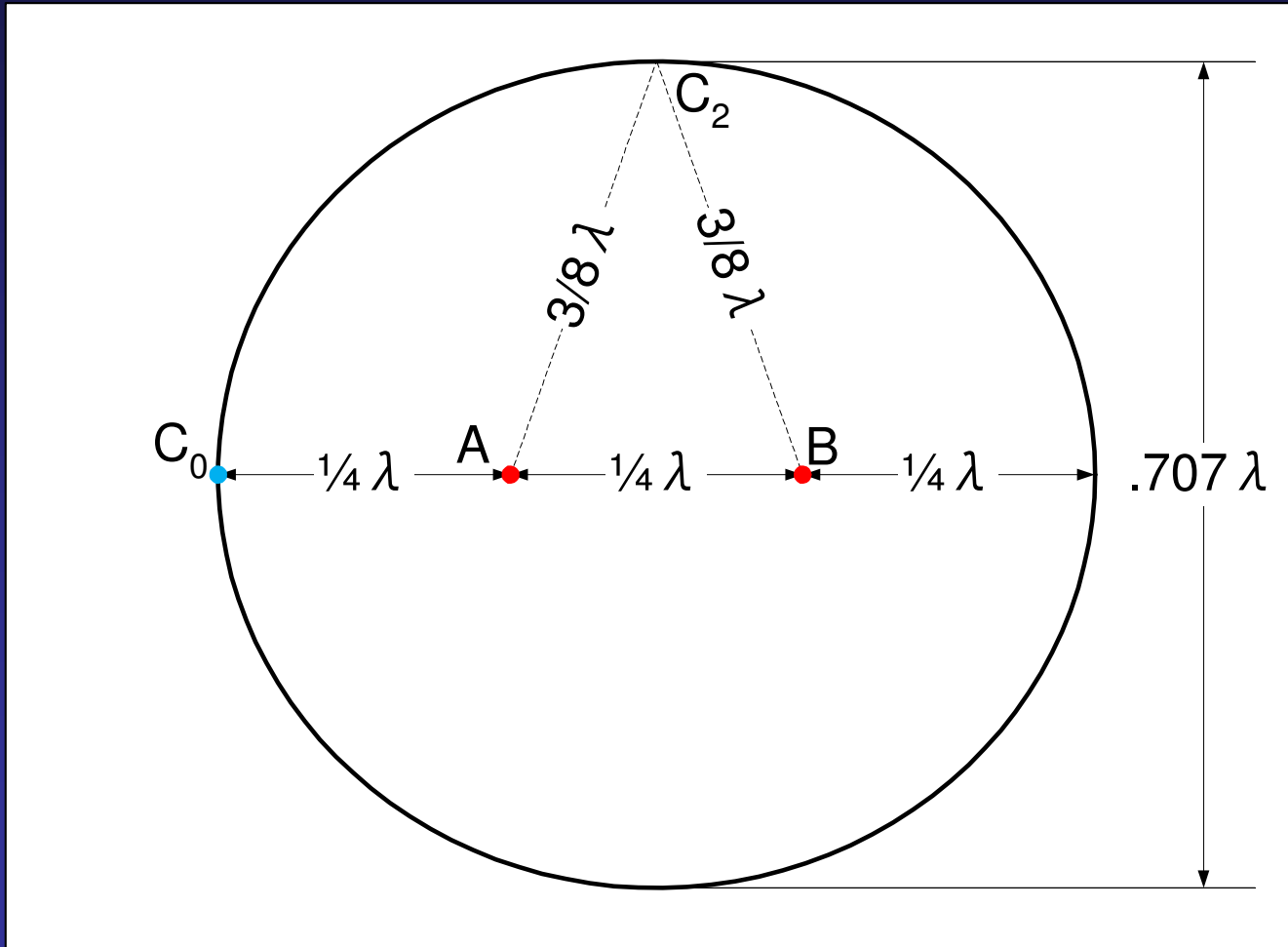

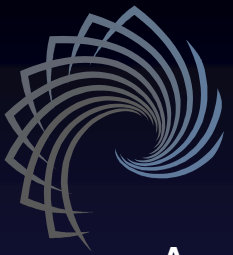

# Connecting a Load

- Again, if a magloop antenna at B is part of a tuned tank and we connect a load across that tuned tank, power is transferred to that load. For example, light bulbs will light up, and at the same time, the signal reflected back to A, rather than reflecting the load back, will reflect back a signal that reduces the loading on A. With an important stipulation!

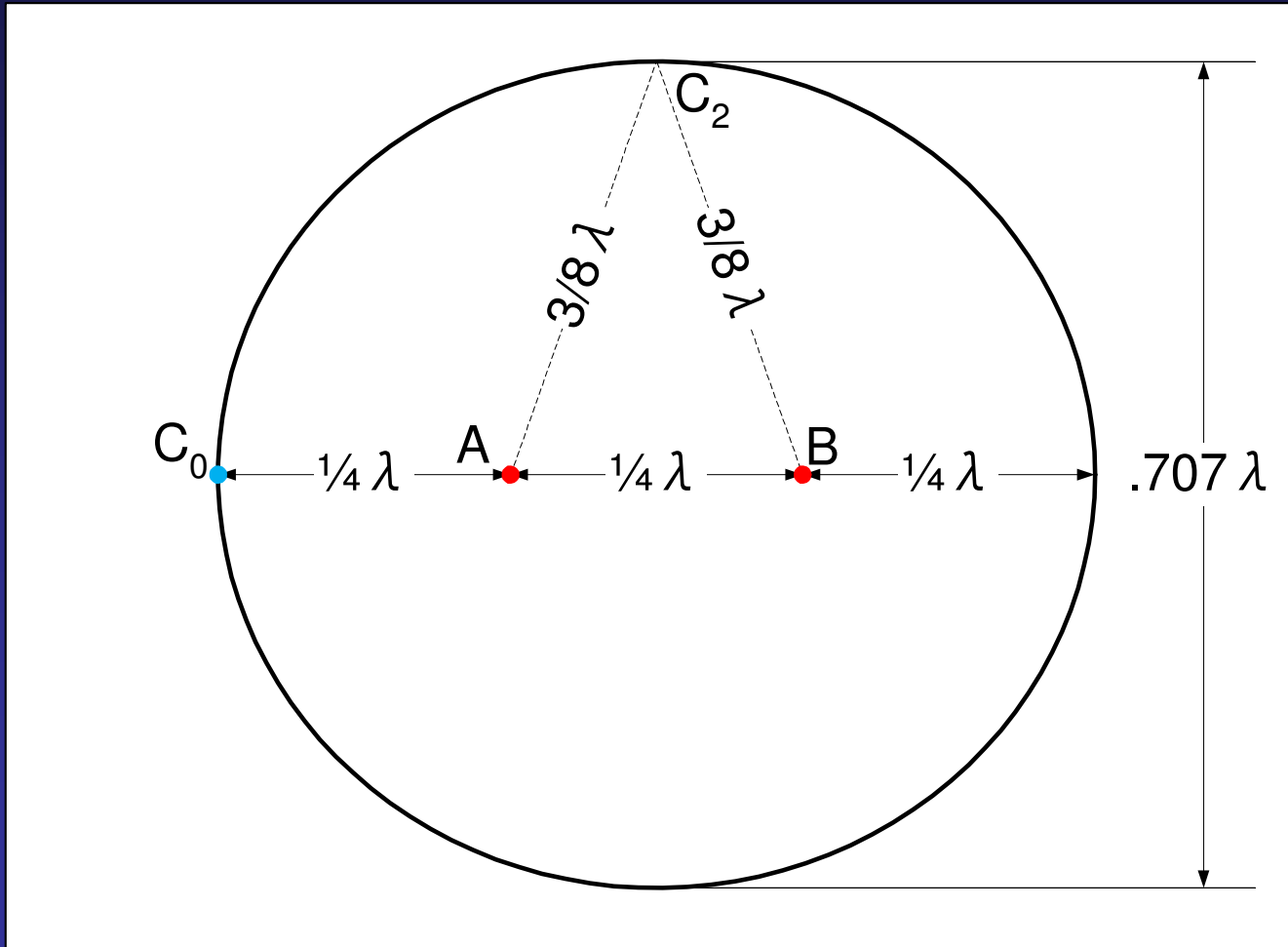

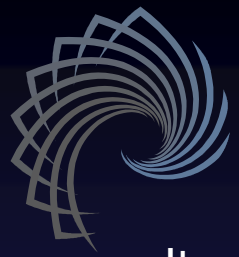

# Impedance Matching can be Important

- It might be, that a load across a tuned tank at B would reduce the maximum current at B. That might cause less load reducing at A. Similarly, if a load is connected in series with the tank at B rather than in parallel, it might not be possible to have good impedance matching so as to get power transferred from A without loading A equal to the power transferred. Experimentation is needed to gain understand.

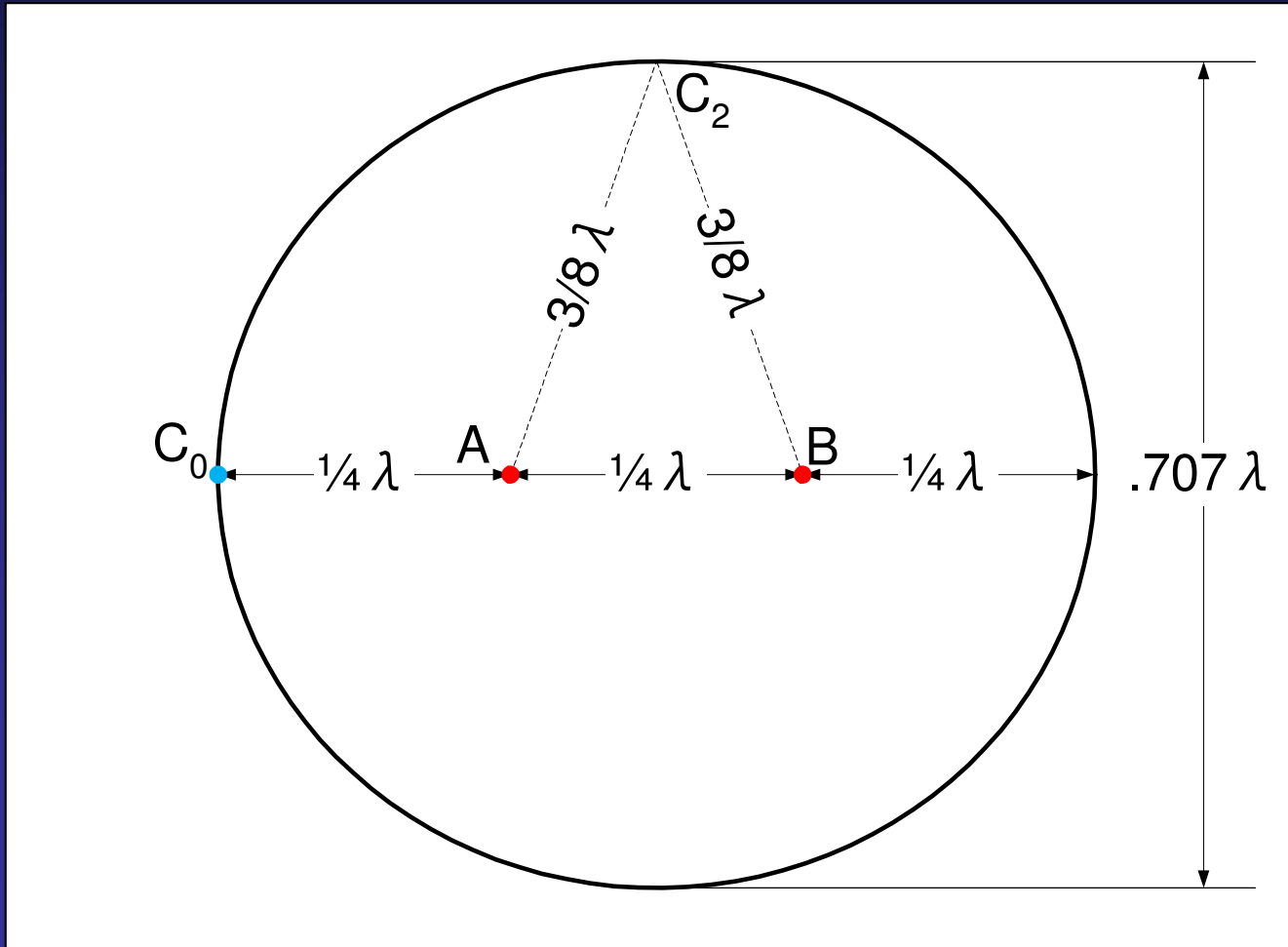

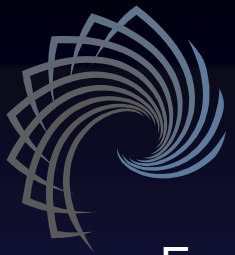

# What if we place a ferromagnetic material at B?

- Examples from: <http://hyperphysics.phy-astr.gsu.edu/HBASE/solids/ferro.html#c5>

Some representative relative permeabilities:	
magnetic iron .....	200
nickel .....	100
permalloy..... (78.5% nickel, 21.5% iron)	8,000
mumetal..... (75% nickel, 2% chromium, 5% copper, 18% iron)	20,000

at a magnetic flux density of  $0.002 \text{ W/m}^2$

From the same website above:

“ When ferromagnetic materials are used in applications like an [iron-core solenoid](#), the relative permeability gives you an idea of the kind of multiplication of the applied magnetic field that can be achieved by having the ferromagnetic core present. So for an ordinary iron core you might expect a magnification of about 200 compared to the magnetic field produced by the solenoid current with just an air core. This statement has exceptions and limits, since you do reach a saturation magnetization of the iron core quickly, as illustrated in the discussion of [hysteresis](#). “

- Before we review the effects, lets review air cores versus iron cores.

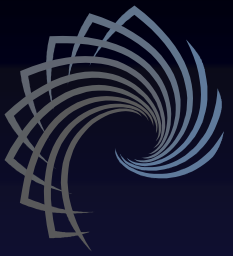

# Magloop with an Air Core

- If we apply an AC signal to a wire loop with an air core, then for a given maximum current,
  - The magnetic field strength is relatively low.
  - With each half cycle of the AC signal, the wire loop's magnetic field builds up, cuts across the wire loop and causes a CEMF that opposes the change in current flow in the loop.
  - The inductance is just the inductance of the wire loop and the magnitude of inductance determines how much CEMF is generated that slows down the change in current flow thus slowing down the build up of the loop's magnetic field each time the current level is increasing.
  - The EM energy radiated equals the energy from a signal generator that is not returned to the generator from the wire loop during periods when the magnetic field is collapsing before switching polarity. (assuming no resistance losses)
  - The energy radiated away comes from the signal generator.

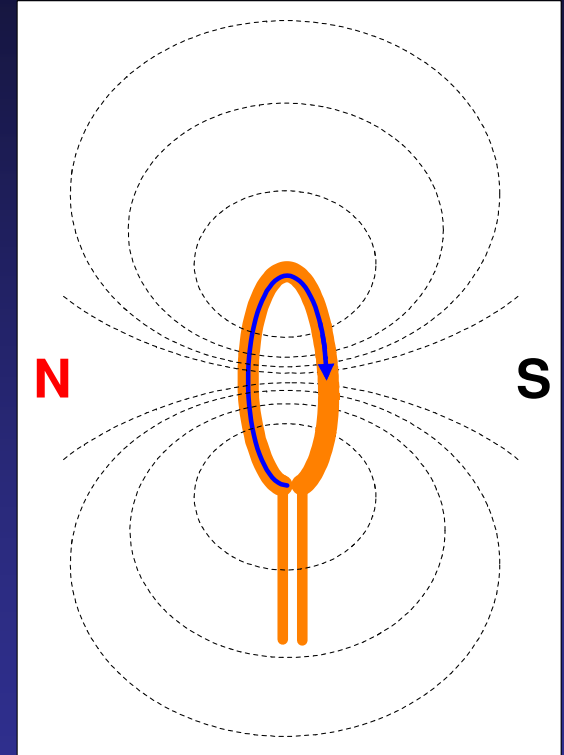

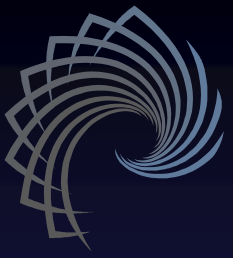

# Magloop with an Iron Core

- If we apply an AC signal to a wire loop with an iron core, then for a given maximum current,
  - The inductance is now magnified by the relative permeability of the iron core.
  - A much stronger magnetic field is generated when the magnetic domains of the iron core turn to align with the magnetic field from the wire loop.
  - This generates a much larger CEMF in the wire loop which greatly reduces the rate that current flow can change.
  - A much larger signal must be applied to achieve the same current flow in the same time period of each AC cycle.
  - Again, the EM energy radiated equals the energy from a signal generator that is not returned during periods of each cycle when the magnetic field is collapsing before switching polarity. (assuming no resistance losses)
  - A proportionally greater amount of energy is radiated away and the signal generator provides that extra energy. (Conservation of energy)

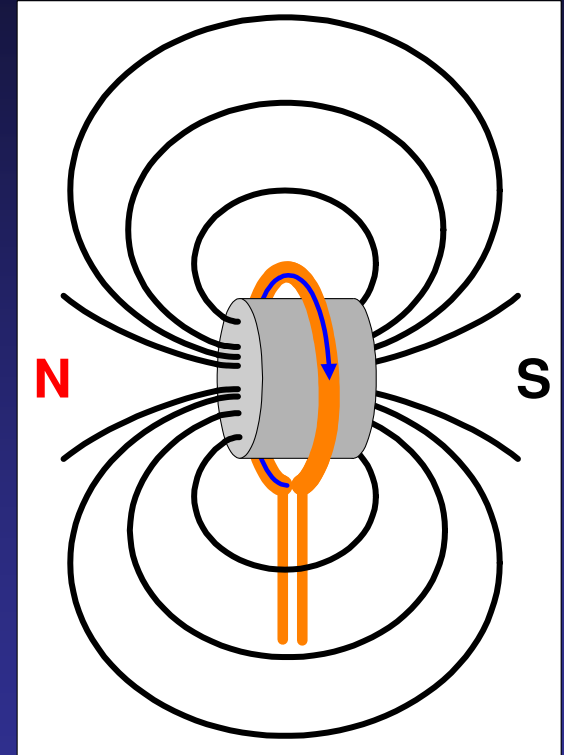



# An Iron Core at $\lambda/4$ distance

- With an Iron Core at  $\lambda/4$  distance, the magloop antenna doesn't have a greater inductance from an iron core inside it nor greater CEMF opposing the build up of current because the iron core is not able to immediately respond to changes in current in the magloop antenna.
- The iron core will not respond until a  $\lambda/4$  time delay.
- Each signal cycle's change in polarity causes alternating EM radiation from A that converges on B, at which time the iron core will begin to respond and its magnetic domains will turn to align with the external magnetic field that originated from A.
- When the magnetic domains of the iron core change orientation, that generates a magnetic field change that propagates back to the magloop antenna at A.
- By the time this signal arrives at A, rather than opposing the change in current in the magloop antenna, it generates a current flow in the same direction the signal generator is causing in the magloop antenna already.
- The induced current is even greater than a "shorted" condition's maximum current set by resistance within the source, transmission line and antenna.

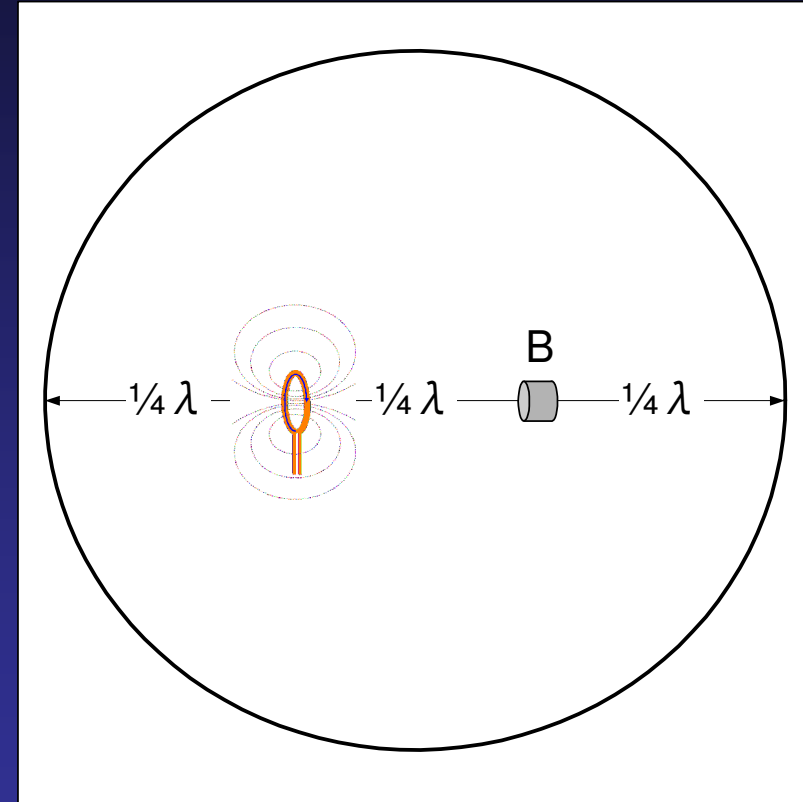

# An Iron Core at $\lambda/4$ distance continued

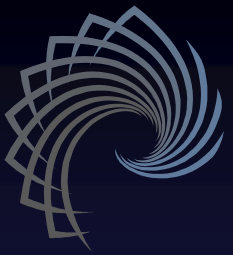

- In fact, if after generating an initial pulse, the signal generator is disconnected from the magloop antenna at A and a load only is left attached, then when the magnetic field from the iron core arrives, it should induce a current flow through the load.
- The current flow around the magloop and through the load will cause another magnetic field of opposite polarity to radiate outwards from the magloop at A.
- This will propagate over and converge on B, swap the iron core's direction of magnetization and the process will repeat so an oscillation begins.
- The iron core now becomes the signal source and the maximum signal amplitude possible is determined by the maximum magnetic field density that the iron core can generate before the iron core becomes saturated, as represented by a hysteresis curve for the iron core's magnetic properties.
- Other ferromagnetic materials may work also and the effect begins as soon as the initial signal received by the core material is strong enough to overcome the coercivity of the material.

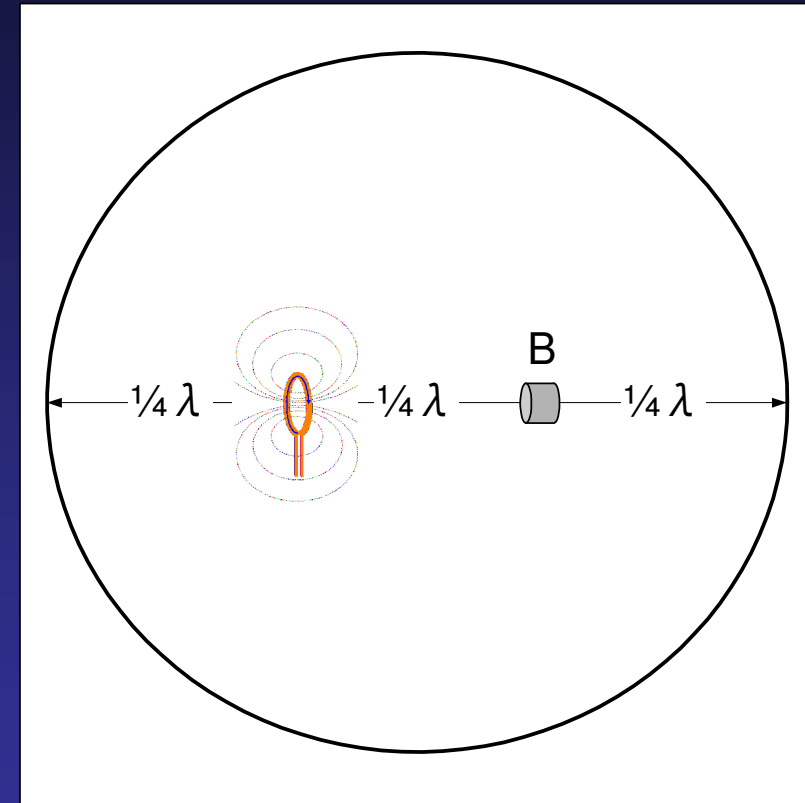

# An Iron Core at $\lambda/4$ distance continued

- The effect depends on the core material having a relative permeability high enough and a  $BH_{\max}$  (Maximum Energy Product) high enough to radiate more electromagnetic energy back to the magloop antenna than was transmitted.
- The energy received at A must be higher than the energy losses due to:
  - imperfect antenna efficiency, (antenna heating).
  - imperfect reflections off cavity inner walls, (heating of the cavity walls).
  - imperfect focusing of the reflected signals at each foci, (possible phase smearing).
  - losses in the core material
- **NOTE: Energy is conserved.**

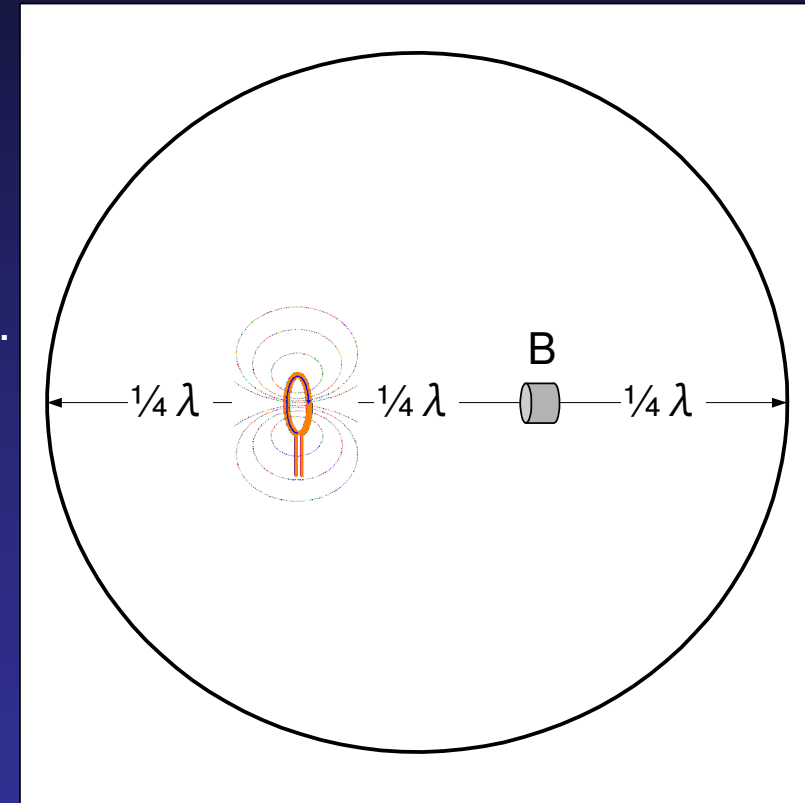

The energy appears to come from the core material itself but there are processes that allow this to occur.

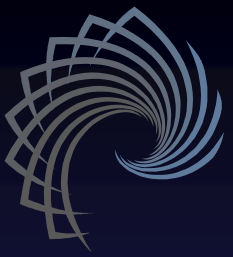

# Where does the energy come from?

- According to [classical electrodynamics](#), all electrically charged particles, like quarks of protons and neutrons, as well as [orbital electrons](#), are [radiating away energy](#) from [precessional](#) and [precessional plus orbital motion](#). All electrically charged particles are radiating away energy all the time.
- However, all charged particles absorb just as much energy from all other radiating particles. The absorbed energy applies [electromagnetic forces](#) that naturally move all similar type particles into harmonious precessional motions with all other particles. This results in a vast sea of electromagnetic standing waves among all matter.
- This gives rise to a hidden yet strong tendency towards [harmony and equilibrium](#) among all matter in the universe due to these unseen standing waves and spin interactions among all matter. This tendency overcomes, to a great extent, the tendency towards chaos and [heat death](#) of the universe. This tendency can also be exploited to perform [work](#).
- This is the interaction among all matter that [Ernst Mach](#) alluded to as necessary to cause matter's characteristic of inertia. Einstein later called this [Mach's Principle](#). Einstein studied Mach's ideas while developing his theory of General Relativity.

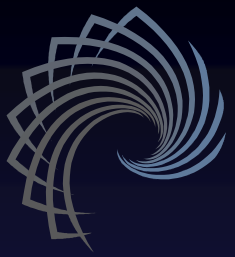

## *Specifically where does the energy come from?*

- Energy lost to a load causes the particles of the core material to lose the energy of angular momentum by the same amount as the energy transferred to a load.
- The charged particles of the core material begin to spin and precess slower. (Something a quantum physicist may not be prepared to accept.)
- However, as soon as there is the slightest change in angular momentum, there will be phase lag in the precessional rotation between the particles' axes of precession and the sea of standing waves.
- As soon as there is a phase difference, the received signals from the sea of standing waves will apply electromagnetic forces that force the magnetic core material's charged particles back up to speed again.
- This is similar to how a wrist exercise "power ball" can be precessed by applying force with the wrist to increase the ball's spin rate. <https://www.youtube.com/watch?v=xE7zFEV1dKk>
- It is also similar to how a planet can have external forces on it that increase its spin rate.

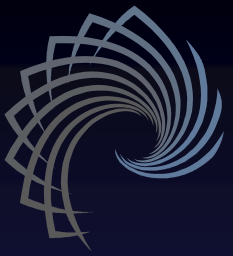

# *Practical Design Criteria for a Prototype*

- The antenna should have high efficiency
- The ellipsoidal cavity's inner wall should have high reflectivity.
- An impedance matching network should match the impedance of a load to the impedance of the antenna and should be able to handle the power output without saturating.

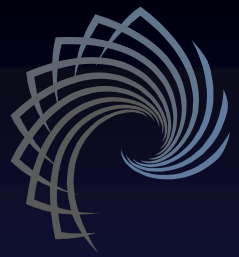

# *High Efficiency Magloop Antenna*

- There are books, websites and forums dedicated to magloop antenna designs.
- Antenna efficiency, also called radiation efficiency, per wiki: "... is the ratio between its radiation resistance and its total resistance ...". It represents how much of the antenna's input power actually gets radiated as opposed to dissipated by things like resistance in the antenna or resistance of the ground in the vicinity of the antenna. In this application, the cavity inner wall is the ground and will have minimal losses. But resistive losses in the magloop antenna metal surface or in connectors are a big concern.
- Both online and downloadable magloop antenna calculators can be found that predict the antenna efficiency for a given design.
- A high Q design is often desired by ham radio enthusiasts because it increases selectivity and reduces bandwidth, both desirable for ham radio receivers and transmitters. But a high Q design causes the electric field component to increase without increasing the magnetic field component. For this application, a strong magnetic field is the primary concern. If a high Q helps that in some way that is great but if it doesn't increase the radiated or received magnetic field energy it doesn't matter much.
- The size, shape and reflectivity of the cavity inner wall will increase Q anyway.
- A tuned capacitor is a major component of ham designs that strive for a high Q, but if you get the antenna impedance you want at the desired frequency without any capacitor then maybe you can do without the capacitor.

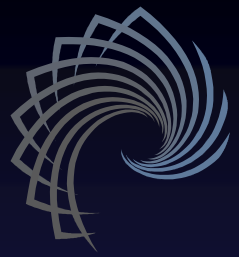

# *The Ellipsoidal Cavity Construction*

- Polished aluminum or copper have good reflectivity in the RF range
- Places that manufacture spun metal parts are capable of making the ellipsoidal cavity.
- This is what we are talking about: <http://www.metalspinningworkshop.com/>
- Examples: <http://www.centurymetalspinning.com>  
<http://www.helandermetal.com/metal-hemispheres-metal-cones.html>
- The frequency determines wavelength ( $\lambda$ ) and this determines the size.
- If the ellipsoidal cavity is  $3\lambda/4$  across and the operating wavelength is 70cm then the cavity will have an inner surface  $70 \times 3/4 = 52.5\text{cm}$  across.
- The inner surface needs to be polished mirror smooth and possibly have a silver or gold coating for the lowest skin resistance in the RF range.
- A high dielectric protective coating may be desirable to prevent oxidation so as to maintain low skin resistance. It needs to be a high dielectric coating so no current flow through it can cause resistive losses. Polyurethane might be good enough.

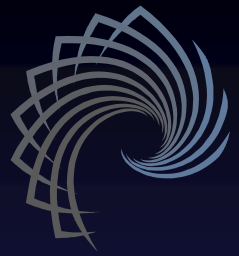

# *Impedance Matching Network*

- The impedance matching part of this proposed design has not been explored yet.
- It may be possible to pulse the unit into operation through a low efficiency impedance matching network.
- Then couple its output through high frequency power diodes to a more typical low frequency utility transformer that can handle a lot of power at more typical AC power frequencies.

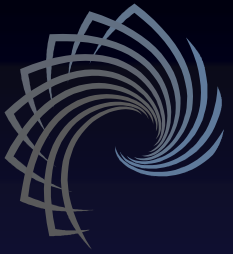

# Power Control

- When I explained this design to my nephew, who is a pretty smart dude, he commented that it seemed like it would immediately go into a runaway condition with an uncontrollably high output level, and he is right.
- If the overall losses are low enough to make it work then the positive feedback from the magloop to the core would possibly make it output too much if, for example, a short was placed across the magloop antenna output. There are several problems actually:
  - How to control the output level?
  - How to modulate the output for a 60Hz output?
  - How to make it fail safe, i.e. if something breaks in some control circuit, it should make it shut down rather than output too much.
  - Making it fail safe is most important.

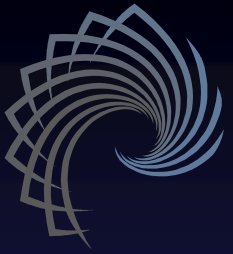

# *Power Control* continued

- A possible solution is to saturate the core with permanent magnets designed not to absorb or reflect the EM radiation from the magloop antenna. The magnets must have sufficient coercivity that the magnetization of the permanent magnets can't get flipped by the EM radiation from the magloop antenna.
- Then use a control winding with a DC current applied to reverse and so neutralize the magnetic fields of the permanent magnets. If the control winding or its drive circuitry fail, then the core becomes saturated which should prevent it from responding to positive feedback from the magloop antenna.
- This would be somewhat similar a saturable reactor with one big difference. What would normally be an AC power input winding would now be an RF input from a magloop antenna at least  $\lambda/4$  away so as to develop positive feedback between the core and the magloop antenna.
- The next problem is modulating the output level for a 60HZ output.



## *After further review ...*

- I was previously discounting the need for a tuned capacitor in the magloop antenna but after further thought;
- If the core was initially pinged with sufficient energy from a magloop antenna so as to start positive feedback between the core and the antenna, there may be other frequencies that the whole system decides to oscillate at besides the intended frequency.
- To keep the whole system oscillating at the desired frequency, a good magloop antenna design is needed probably with a tuning capacitor included.
- The magloop antenna itself should not have parasitic capacitances or inductances that would cause it to resonant at unintended frequencies.
- If the whole system oscillates at frequencies higher than intended, it makes it much harder to control and harder to rectify the output from the antenna without the rectifying circuit possibly overheating.
- Other strange and hard to control conditions may develop as well, related to slowing the spins of the cores' charged particles to slower than other matter in the area.



## *After further review ... continued*

- Else, continue to dispense with a capacitor as part of the magloop antenna and instead warp the perfect shape of the ellipsoidal cavity so that at higher frequencies too much phase smearing would occur and so those frequencies could not support enough positive feedback to maintain oscillations.

*After even further review, see the dilemma realized and discussed on the next slide.*

# Frequency Limits of the Magnetic Core

*i.e. Resonant Cavity Size Limits*

- As the intended frequency increases, a magnetic core's material has a decrease in permeability, develops phase lag in response to external magnetic field changes and develops higher resistive impedance which causes heat loss.
- Higher temperatures cause more permeability loss so the permeability continues to drop off even faster.
- Relevant links:

<http://www.fair-rite.com/newfair/materials67.htm>

<http://www.ieee.li/pdf/viewgraphs/ferrites.pdf>

[http://www.matsceng.ohio-state.edu/ims/LR\\_Ferrites.pdf](http://www.matsceng.ohio-state.edu/ims/LR_Ferrites.pdf)

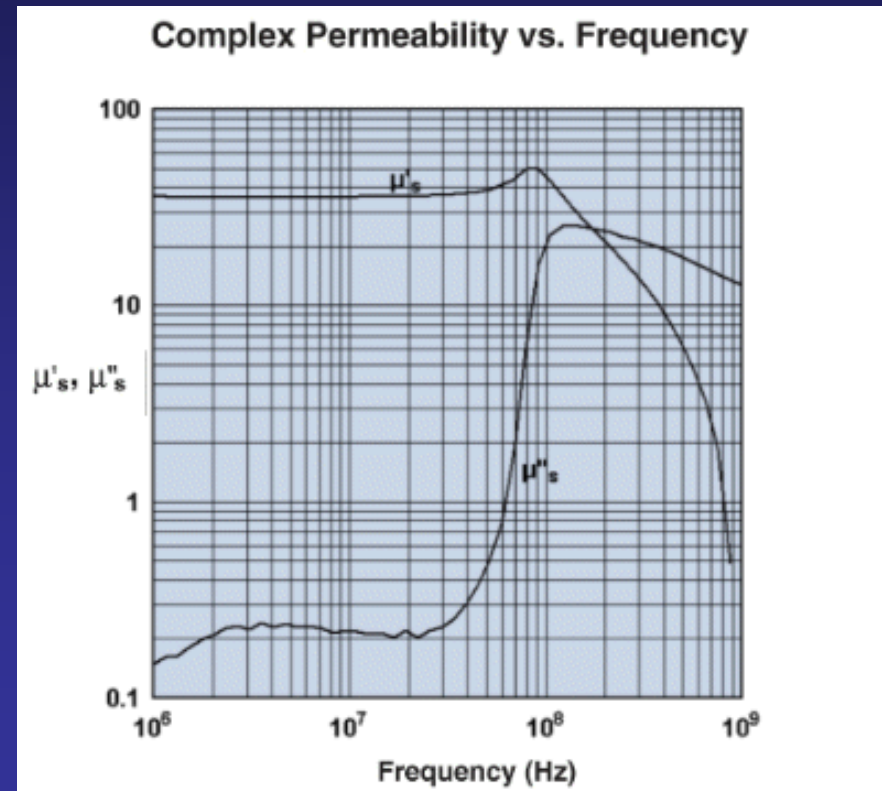

Fair-Rite Material # 67

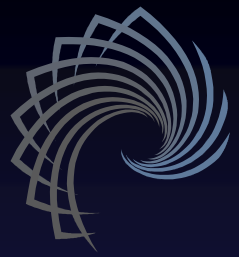

# Frequency Limits of the Magnetic Core

*i.e. Resonant Cavity Size Limits Continued*

- A particular magnetic material's characteristics at higher frequencies determines the minimum size limit of the ellipsoidal cavity.
- For example, if for Fair-rite material #67, we use a target frequency of 22MHz for minimal losses, then 1 wavelength would be:

wavelength ( $\lambda$ ) =  $c / f$ , where  $c = 3 \times 10^8$  m/s (velocity of light) so  
 $(3 \times 10^8 \text{ m/s}) / (2.2 \times 10^7 \text{ Hz}) = 13.64 \text{ meters}$

- So the smallest possible ellipsoid cavity size of  $3\lambda/4$  across would be a width of 10.23 meters across.
- The following slides explain why magnetic ferrite performance decreases and what the alternatives are.



# An Alternate Approach

to get around the frequency (and size) limits

- As explained on page 11 of this review of ferrite materials: [www.matsceng.ohio-state.edu/ims/LR\\_Ferrites.pdf](http://www.matsceng.ohio-state.edu/ims/LR_Ferrites.pdf), as the frequency increases, it approaches the ferromagnetic resonant frequency.
- In magnetic materials, it is the combined direction of the uncompensated electrons' **orbital spin**, **orbital precession**, **electron spin** and **electron spin axis precession** that change orientation and cause the material's magnetic field orientation to change.
- As the frequency increases, that an externally applied magnetic field is changing direction, the changing external magnetic field couples less to the frequency that the Z axis re-orient to alignment with it and couples more to the continuously precessing J axis.

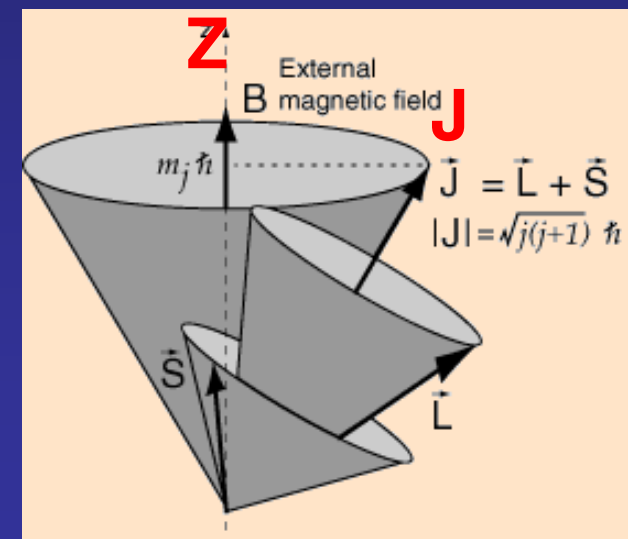
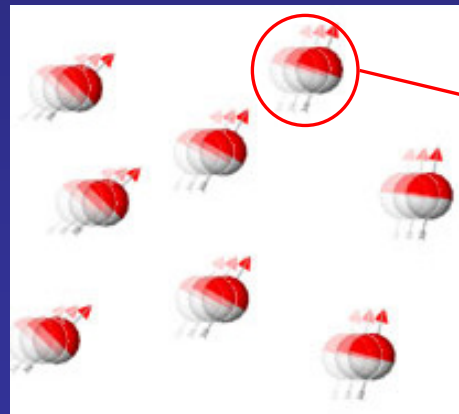
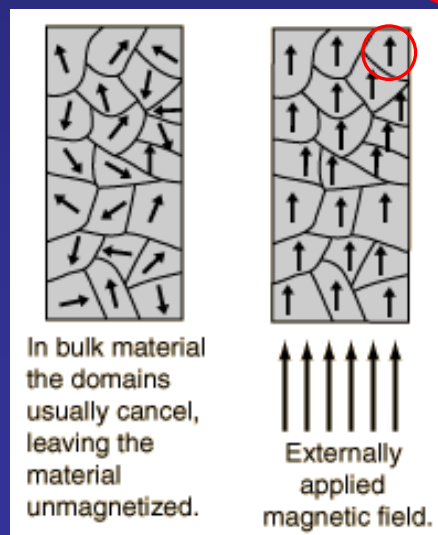

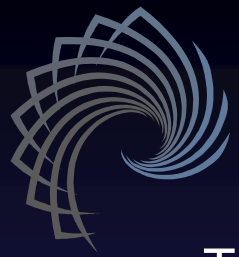

# *An Alternate Approach*

## *continued*

- The frequency the J axis wants to precess depends on the strength of an external static magnetic field pulling in line with the axis of precession.
- This is similar to how a tilted gyroscope would precess at different rates if the gravitational field strength were changed that pulls along its axis of precession.
- There is a different class of ferrites that are designed for use at microwave frequencies with these characteristics in mind.
- Reference: [http://www.temex-ceramics.com/site/fichiers/TEM01\\_Ferrite.pdf](http://www.temex-ceramics.com/site/fichiers/TEM01_Ferrite.pdf)
- For our particular application, we need a toroid shaped core so we can wrap a DC winding around it.
- The current through this winding should be adjustable so as to adjust the toroid's static magnetic field strength and this in turn will set the ferromagnetic resonant frequency.
- We want to test the device's response as we adjust the magnetic material's resonant frequency relative the ellipsoidal cavity's resonant frequency and the magloop antenna's resonant frequency.

# The Prototype Test Setup

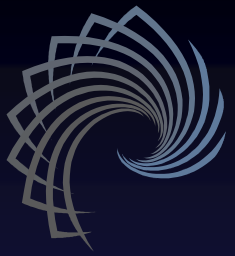

Precessing spins synchronize with incoming waves from the magloop antenna and radiate larger waves back to the magloop antenna.

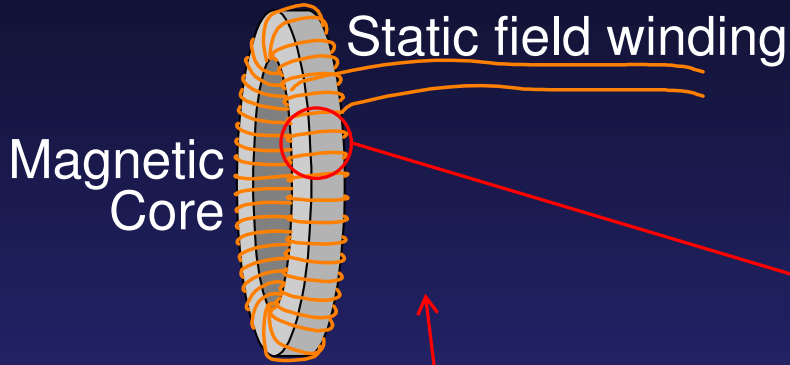

This static field strength is set by the field coil current level.

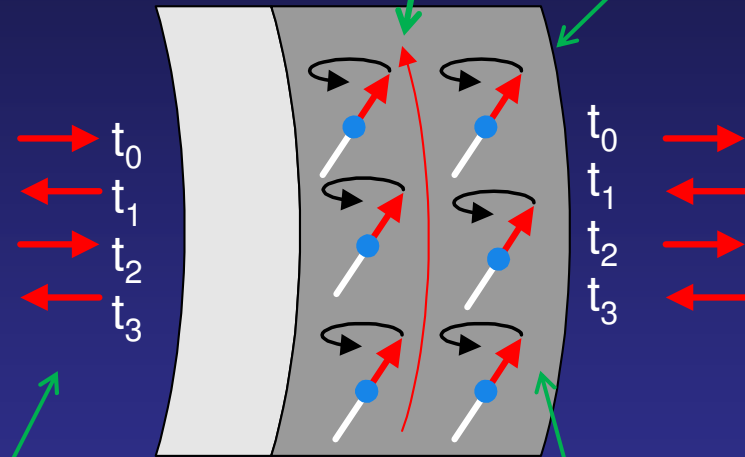
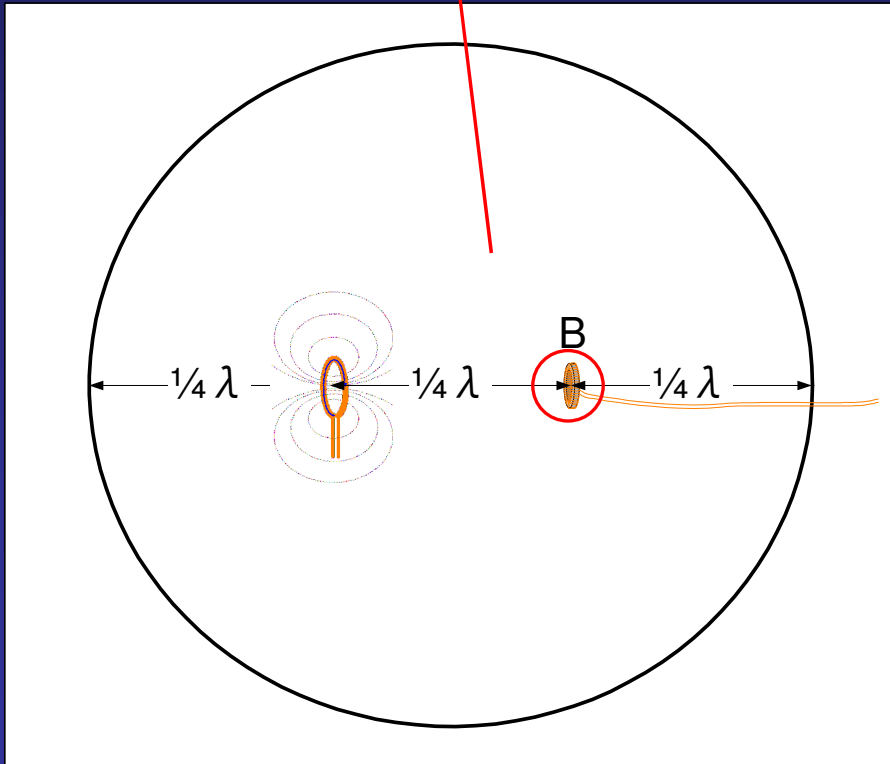

These magnetic waves propagate to the right side of the toroid from the left interior walls.

These magnetic waves propagate to the left side of the toroid from the right interior walls.

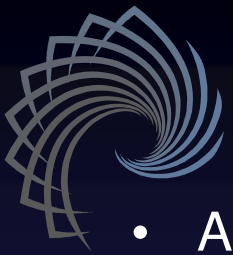

# Design of the DC winding

- At HF and VHF frequencies, the target magnetic core material needs a DC current winding around the core to control its saturation point so as to control the RF output level. It functions similar a saturable reactor control winding.
- At UHF and SHF frequencies, the target magnetic core material also needs a DC current winding around the core but this time it is used to control the ferromagnetic resonance frequency.
- At both frequency bands, we don't want RF coupling into the control winding and we don't want the inter-coil capacitance to short out the RF signal to the core. This is the same dilemma solved by [US patent 5770982](#):
- In this patented design, the problem is solved by winding the RF input in a figure 8 so that the RF induced EMF in each core is equal and opposite so cancels for the control winding.
- Reciprocally, the inter-winding capacitance effects are equal and opposite so they don't appear as a short to the RF winding.
- On our design, since we can't figure 8 the RF input from the magloop antenna, we will do it to the control winding instead.

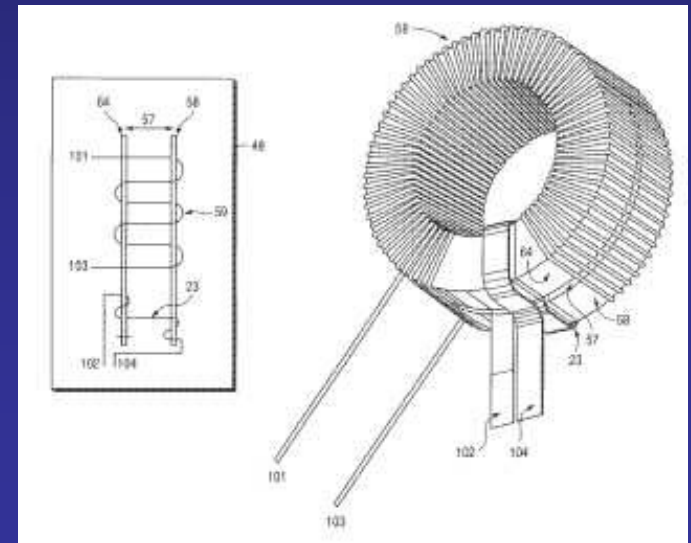

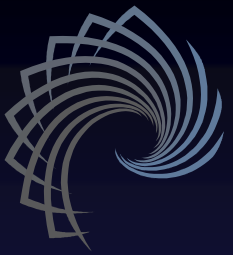

# Design of the DC winding *continued*

The static magnetic fields in the cores are in opposite directions, but the spins should still be able to precess in sync in the left and right directions as stimulated by the signal from the magloop antenna. Notice all “Norths” will be pointing to the right then to the left at the same time in response to the incoming RF magnetic field orientation changes.

Double Magnetic Core

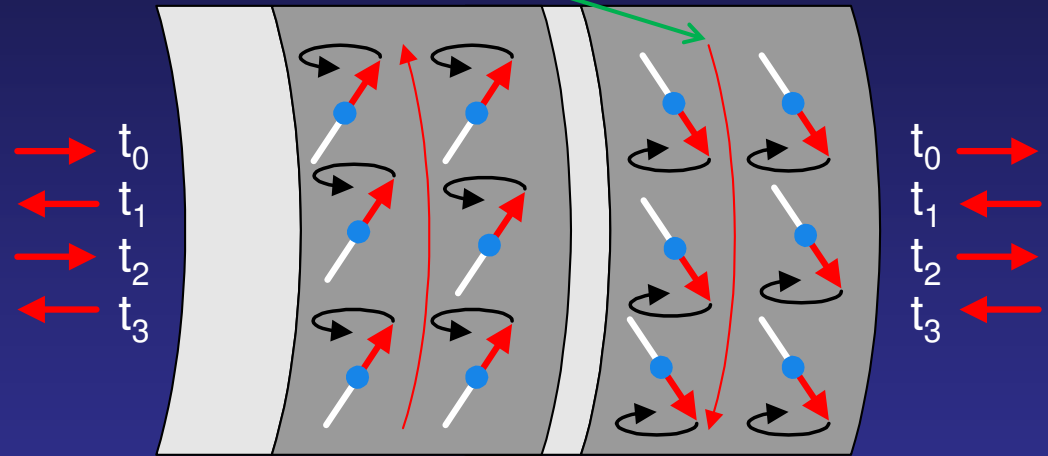
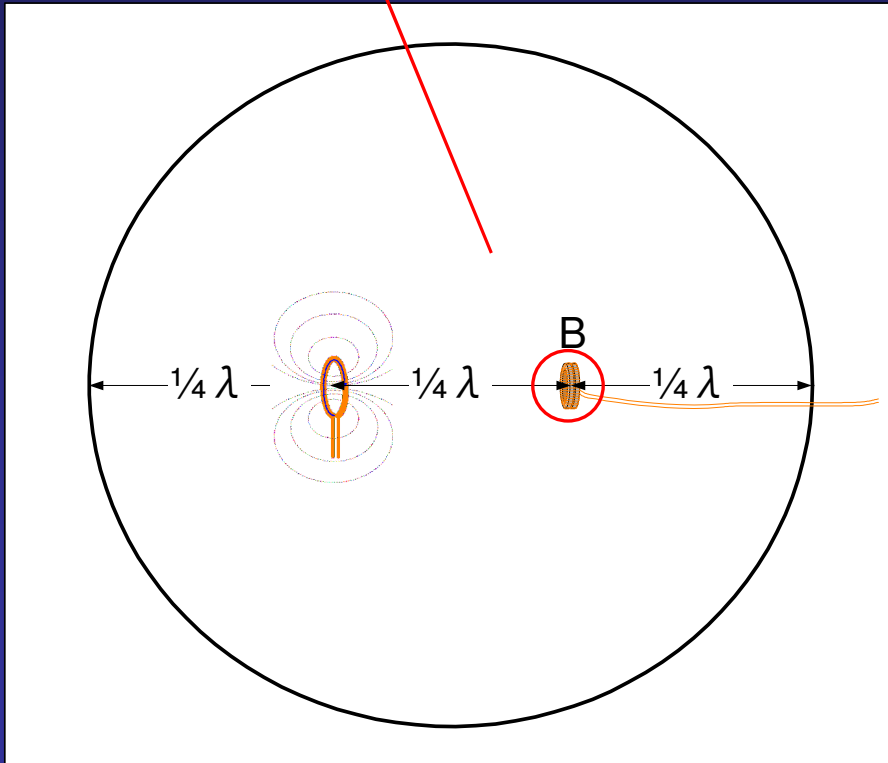
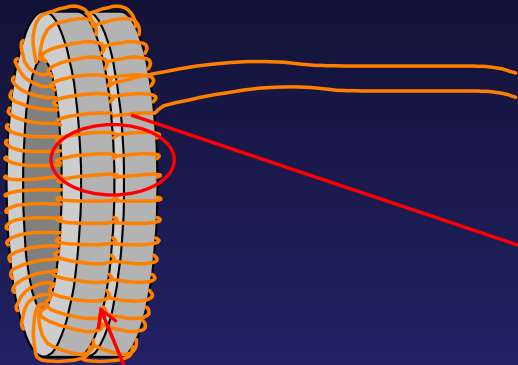

Static field winding cross section view

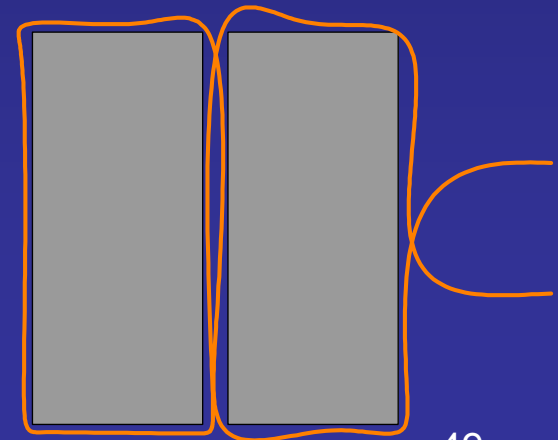



# *More Design Dilemmas*

*that could be solutions to other designs*

- Even though the inter-winding effects cancel by doing the figure 8 around dual cores, the coil as a whole, looks like a larger single turn shorted loop to the incoming RF. The effective loop is in a plane parallel with the cores.
- Maybe a shorted loop is not a problem because a short reflects back to the magloop antenna as an open.
- It is only a problem if it shorts the radiated output from the precessing spins in the 2 cores,
- **but regardless** of the figure 8 winding pattern, the signals radiated from the cores should not get shorted as long as they are synchronized.
- **but regardless of whether** the spins are precessing and counter precessing **or not** they don't induce current in the figure 8 winding pattern.
- **But!** the radiated toggling magnetic waves will not induce current in the cavity walls either so will pass through without reflecting off the walls.
- This makes a great way to transmit information through thick walled Faraday cages or mountains, as long as you have a circuit that can receive them, i.e. a magnetic material tuned to resonance at the frequency of the received magnetic waves. The magnetic material should be designed with very low damping of the precessing spins so as to resonant well.

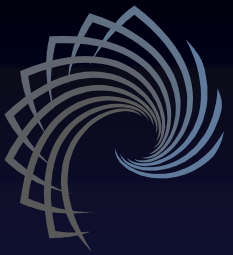

# Two modes of radiated magnetic waves

Magnetic waves in this direction do not induce current flow in conductors but can still push and pull on magnetic dipoles in magnetic materials.

TEM (Transverse Electro-Magnetic) radiation in this direction will induce current flow in conductors

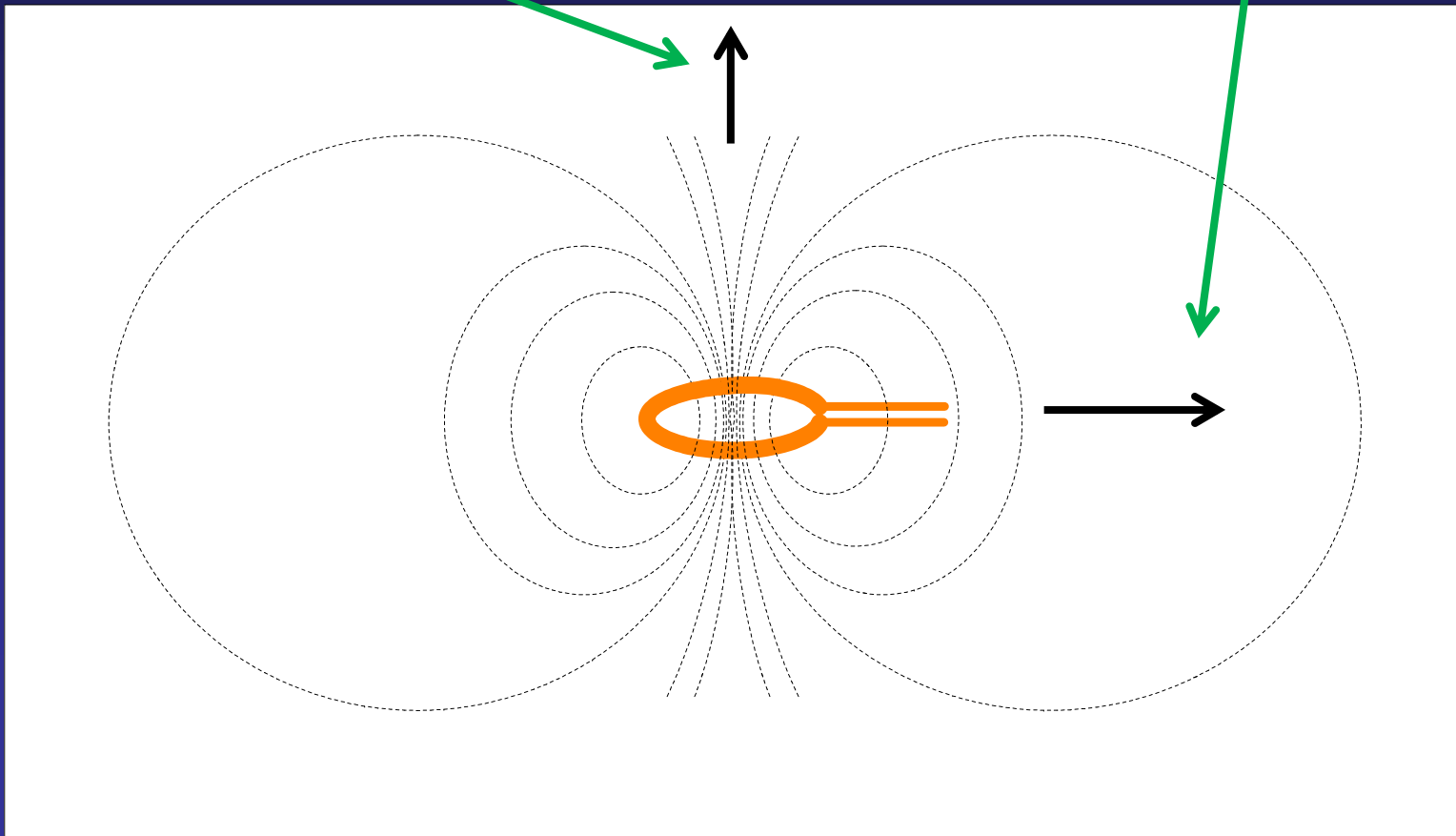

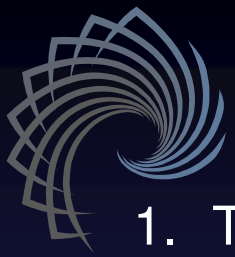

# Two modes of radiated magnetic waves

## continued

1. To induce current in a conductor, the magnetic component of EM waves needs to be at an angle to the direction of propagation.
2. TEM waves have the magnetic component at right angles to the direction of propagation.
3. There can be, and usually are, directions from a signal source in which the magnetic component of the EM waves is somewhere between a right angle and exactly aligned with or against the direction of propagation.
4. In these cases, only that vector portion that is at right angles is considered part of the TEM radiation.
5. To push and pull on the magnetic dipoles in a magnetic material, it doesn't matter if the magnetic field component of an EM wave is at right angles or is alternating directly with or directly against the direction of propagation.
6. Either way, it will push and pull on the magnetic dipoles of a magnetic material used to receive the signal.
7. Magnetic waves that have the magnetic field component aligned with or against the direction of propagation can pass through a Faraday cage because no current flow is induced in the conductive cage so the signal cannot be reflected off the cage's conductive surface.

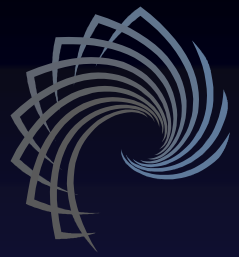

# Magnetic waves from a ferrite core versus magnetic waves from a magloop antenna

- When current increases in one direction or the other in a magloop antenna, an increase in magnetic flux density propagates out from the antenna.
- With the magloop antenna oriented parallel to the conductive surface, the surface directly to the right of the magloop antenna (Area 1) experiences a minimum of magnetic flux moving out to the sides of the direction of propagation and so induces a minimum of current flow in the conductive surface.
- Slightly more out to the sides of the direction of propagation (Area 2), there is slightly more magnetic flux moving out to the sides of the direction of propagation and so to that extent it induces current flow in the conductive surface.
- Similarly, the further out the magnetic flux is from the direction of propagation, the more it cuts through the conductive surface in a motion that is at right angles to the direction of propagation and so this induces more current flow in the conductive surface.

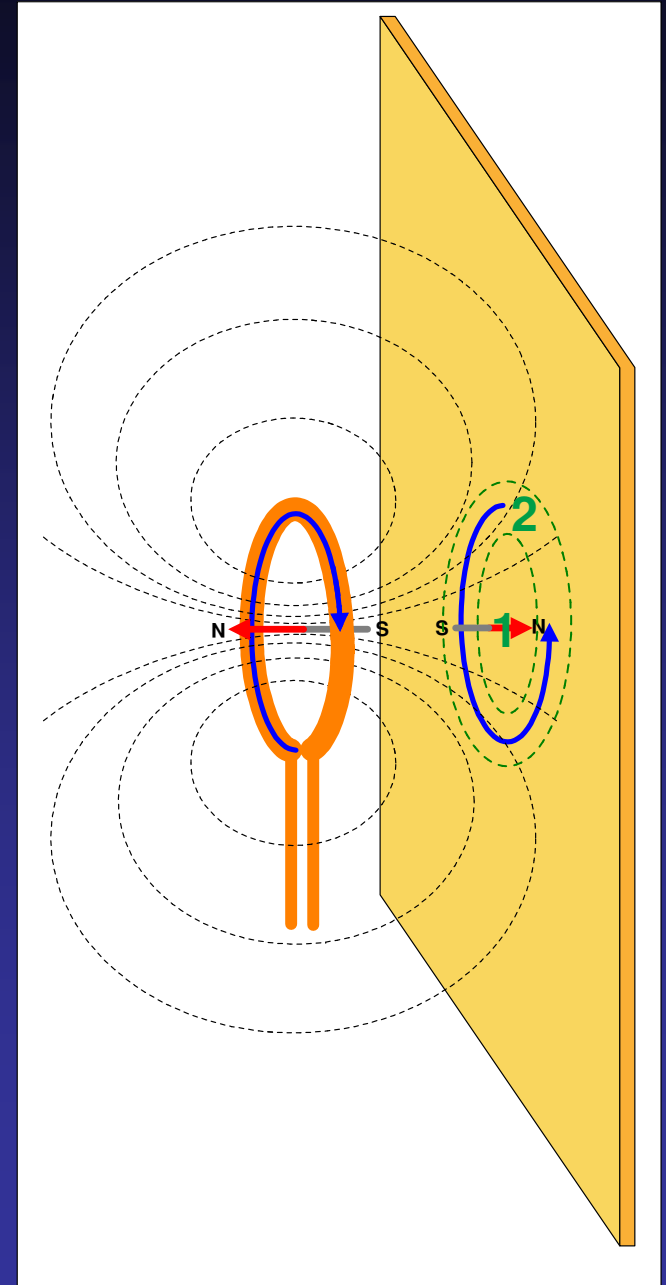

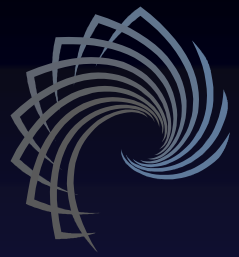

# Magnetic waves from a ferrite core versus magnetic waves from a magloop antenna continued

- Within a ferrite core, when the individual magnetic domains rotate to become more aligned with an external magnetic field, all their individual contributions to the total magnetic flux stay the same magnitudes but sum together more and more.
- As each individual domain's magnetic field rotates to become aligned, the area of the conductive surface to the immediate right will experience each domain's magnetic field sweeping across from various angles around the centerline of the core from every position within the core.
- 50% sweep to the right from a direction more toward the centerline and 50% sweep to the right from a direction more towards the outer circumference of the core.
- The net result is that in the area of the conductive surface immediately to the right of the ferrite core there are as many individual magnetic fields inducing clockwise current flow as there are inducing counter-clockwise current flow.

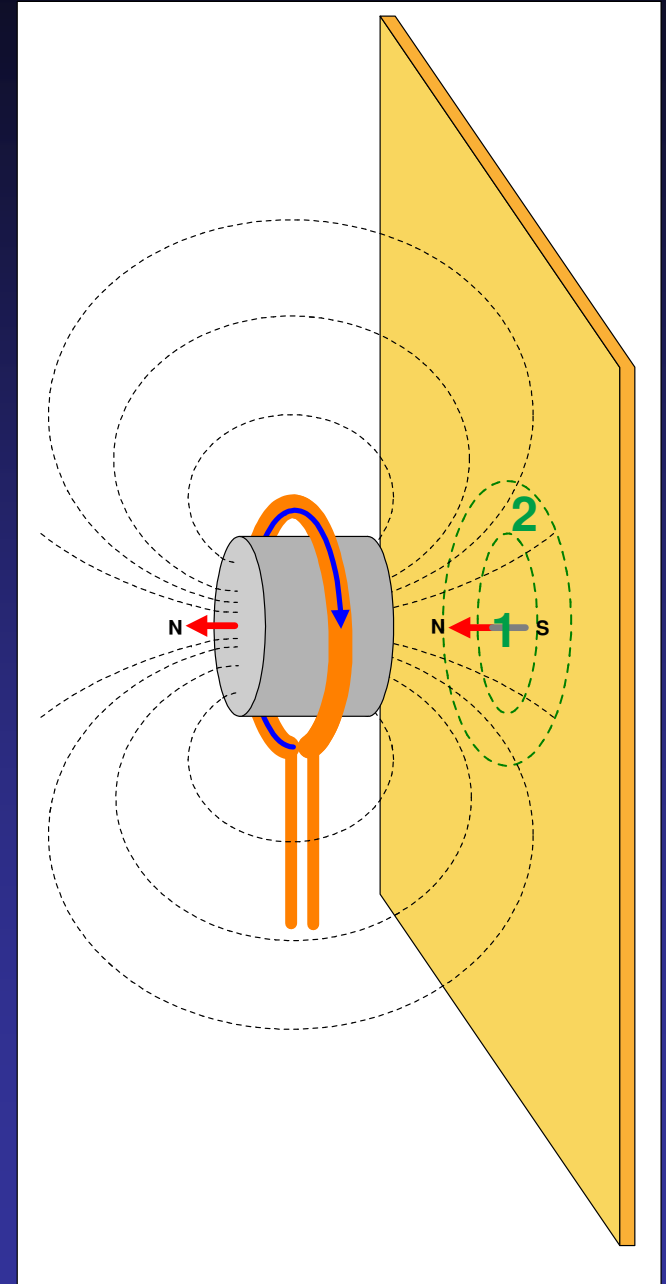

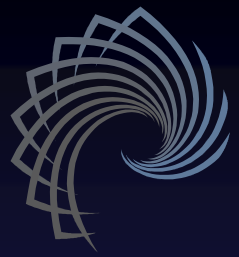

# Magnetic waves from a ferrite core versus magnetic waves from a magloop antenna continued

- Directly to the right of the ferrite core and also further out to the sides of the conductive plate the total magnetic flux from all the individual magnetic domains will increase as the individual domain's directions become more aligned.
- This increase in magnetic flux may have an effect equal to the lines of magnetic flux expanding out from the center line and so may be equivalent to magnetic flux sweeping across the surface from the centerline outward and so would still induce current flow as shown.
- This all needs to be checked with experimentation to see if reality matches the proposed ways of visualizing what is happening.

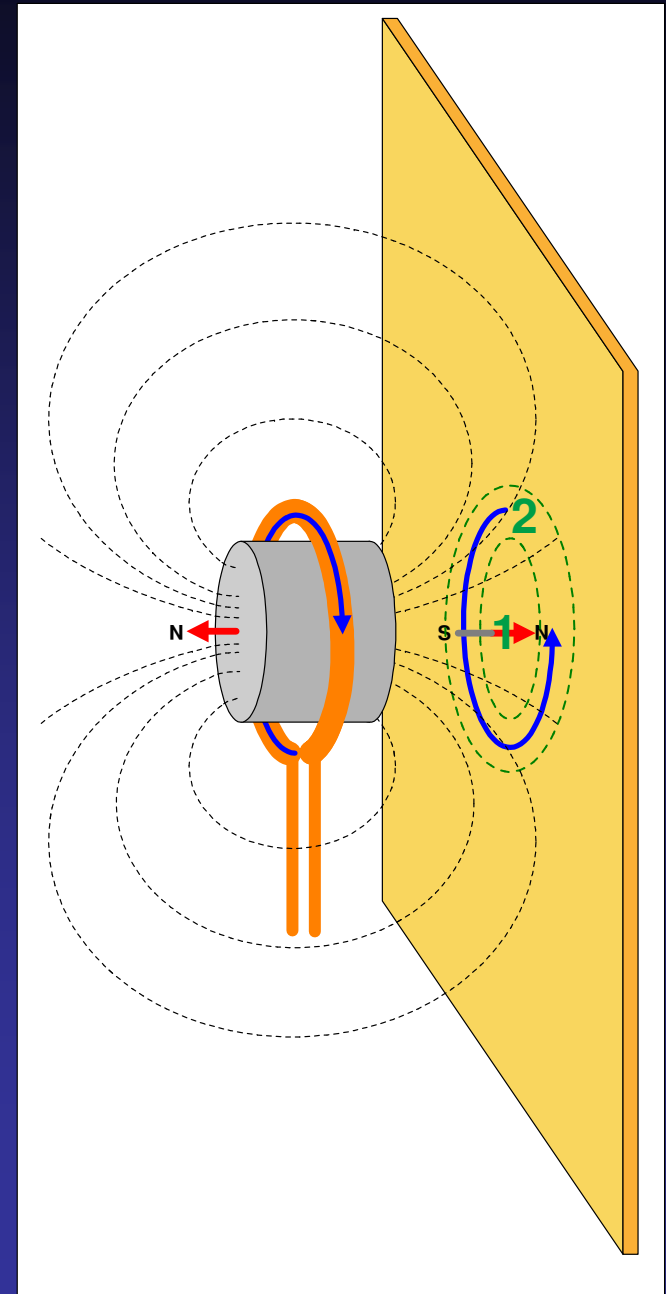

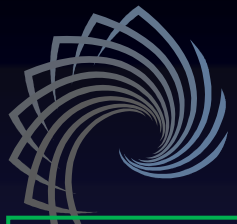

# Antenna for Magnetic waves versus TEM waves.

Magnetic waves in this direction pass through cavity wall (Faraday Cage) and stimulate the resonant frequency of the core's precessing and counter-precessing electrons.

TEM radiation in this direction will stimulate the resonant frequency of the cores' precessing and counter-precessing electrons also, but requires a hole in the cavity wall (Faraday cage).

The DC field winding current sets the resonant precession frequency to match the cavity resonant frequency, sized for incoming signal.

Magloop antenna output

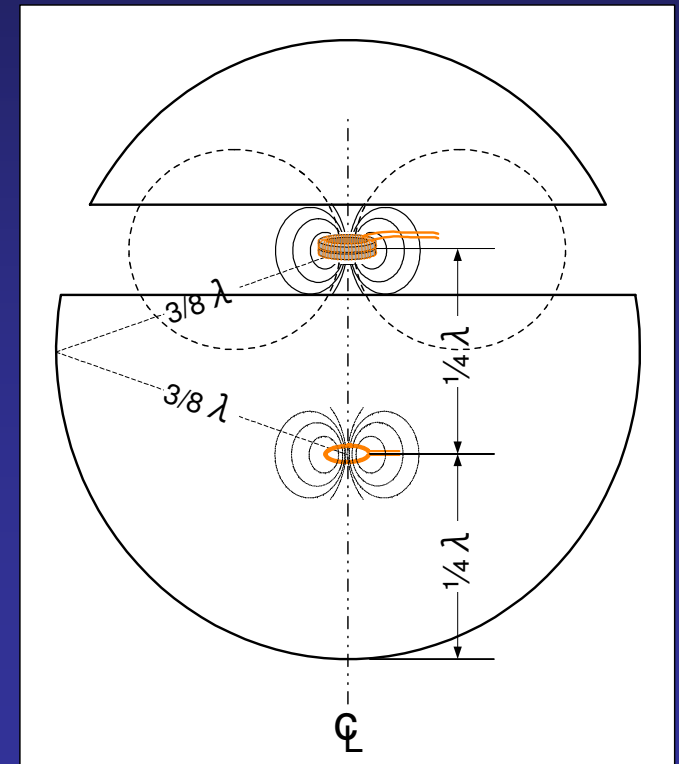
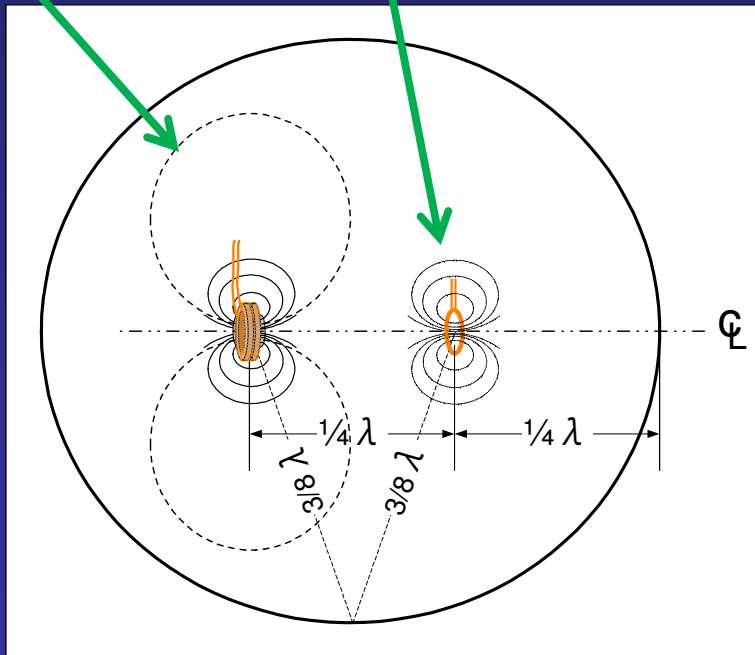



# Design criteria for a prototype

- The ellipsoidal resonant cavity size is determined by the chosen frequency.
- A frequency of 1282.5MHz is chosen because it is within the 23cm amateur band at a location where a Notice is allowed to transmit with up to 5W of RF power. Reference: <http://www.arrl.org/graphical-frequency-allocations>
- This makes the cavity size manageable enough for a DIY person to experiment in their home and it keeps down the cost of the cavity versus larger sizes.

**Specifications for this target size:** <http://www.1728.org/freqwave.htm>

- $\lambda = c/f$  and  $c = 299,792,458$  meters and  $f = 1282.5\text{MHz}$  so
- $1 \lambda = 23.376\text{cm} = 9.20 \text{ in.} = 0.767 \text{ ft.}$
- $3/4 * \lambda = 17.532\text{cm} = 6.902 \text{ in.} = 0.575 \text{ ft.}$
- $.707 \lambda = 16.527\text{cm} = 6.507 \text{ in.} = 0.542 \text{ ft.}$
- $1/4 \lambda = 5.844\text{cm} = 2.3 \text{ in.} = .192 \text{ ft.}$
- $1/8 \lambda = 2.922\text{cm} = 1.15 \text{ in.} = .096 \text{ ft.}$
- With a magloop antenna circumference of  $1/8 \lambda$  then
- Magloop antenna diameter =  $1/8 \lambda / \pi = 0.93\text{cm} = 0.366 \text{ in.} = .0305 \text{ ft.}$

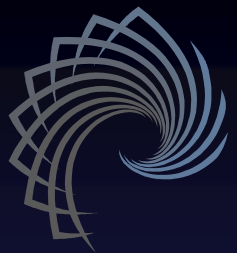

# Design criteria for a prototype continued

Ellipsoidal resonant cavity inside dimensions:

- The below dimensions should support resonant oscillations at 1282.5MHz.
- However, it may be hard to find ferrites that can be un-biased and work at that frequency or even biased with a static field to promote a high permeability response at that frequency.
- So the below dimensions will be tweaked to promote higher frequencies also.

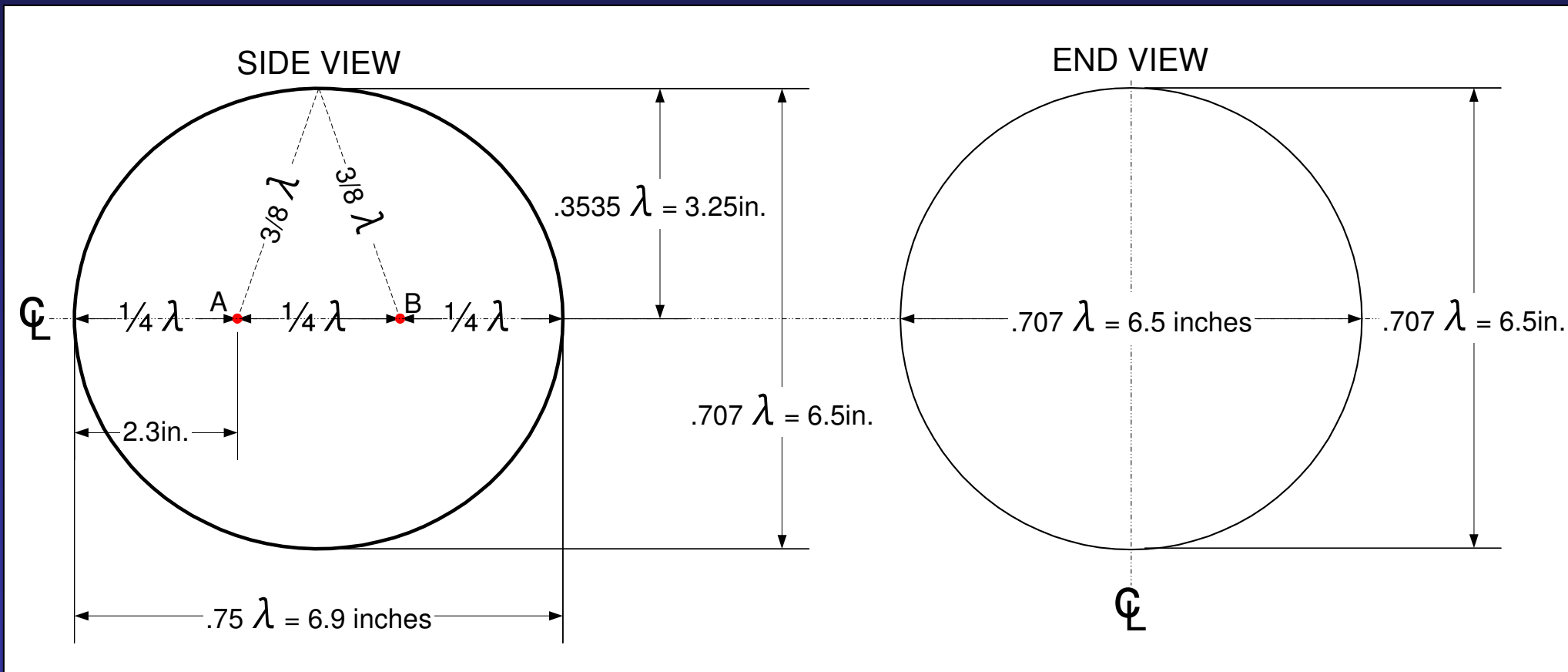



# Design criteria for a prototype continued

Ellipsoidal resonant cavity inside dimensions for higher frequencies:

- For a new higher frequency  $f_2$  with a wavelength  $\lambda_2$  and per the equations on slide 20, if we set  $m = 1.5$  and
- If the distance from the wall to the nearest foci must equal  $\lambda_1/4$  and must also equal  $(m + 1/4) \lambda_2$  then  $\lambda_1/4 = (1.5 + 1/4) \lambda_2$  then  $\lambda_1/4 = (1.75) \lambda_2$  so:

$$\lambda_1 = 4 * (1.75) \lambda_2 \text{ therefore}$$

$$\lambda_1 = 7 \lambda_2 \text{ and } \lambda_2 = \lambda_1 / 7$$

If the distance between foci A and foci B must be  $\lambda_1/4$  and also must be

$(n + 1/4) \lambda_2$  and if  $\lambda_2 = \lambda_1 / 7$  then  $(n + 1/4) (\lambda_1 / 7) = \lambda_1/4$  therefore

$(n + 1/4) \lambda_1 = 1.75 \lambda_1$  therefore  $(n + 1/4) = 1.75$  so  $n = 1.5$

The distance from a foci to the wall center point is:  $(m + n/2 + 3/8)$

so if  $m = 1.5$  and  $n = 1.5$  then  $(1.5 + 3/4 + 3/8) = (12/8 + 6/8 + 3/8) = 21/8 = 2.625$

For the cavity shape to stay the same then  $2.625 \lambda_2$  must equal  $3/8 \lambda_1$

When  $\lambda_2 = \lambda_1 / 7$  then  $2.625 / 7 = .375$  so the same cavity shape should work.



# Design criteria for a prototype continued

Ellipsoidal resonant cavity inside dimensions for higher frequencies:

- So if  $\lambda_2 = \lambda_1 / 7$  then  $f_2 = 7f_1$
- Since  $f_1 = 1.2825\text{GHZ}$  then  $f_2 = 8.9775\text{GHZ}$
- New target frequency: 8.9775GHZ for testing magnetite and hematite rings as the target material.
- As it turns out, the same cavity size and shape will work for any higher frequency  $f_2$  where  $f_2$  is  $x$  times larger than  $f_1$  as long as  $x$  is 1, 3, 5, 7, ....
- The magloop antenna will need to reflect these higher frequencies also, else designed to be tuned to specific higher harmonic frequencies.

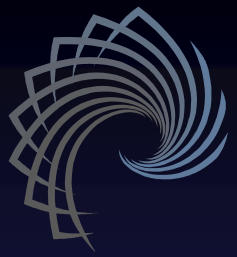

# Design criteria for a prototype continued

## Ferrite toroid core design:

- The ferrite core needs to have a high permeability at 1282.5MHz.
- This requires microwave ferrite which will likely need to be biased with a static magnetic field so as to set a precession frequency that will cause the precessing electron spins to **reflect** rather than absorb RF at 1282.5MHz.
- There are companies that sell microwave ferrites that may work except they are not usually sold in a toroid shape, not specified for reflecting RF with a high permeability response and they can be expensive. Reference:
  - <http://www.temex-ceramics.com/>
  - <http://www.countis.com/>
  - <http://www.trans-techinc.com/>
  - <http://www.pceramics.com/>
  - <http://www.magneticsgroup.com/>
  - <http://www.aft-microwave.com/>

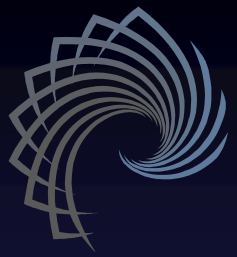

# Design criteria for a prototype continued

## The Ellipsoidal Cavity

- I must choose between a custom fabricated product or an off the shelf product like one of these:
- [http://www.wagnercompanies.com/spheres\\_and\\_hemispheres.aspx](http://www.wagnercompanies.com/spheres_and_hemispheres.aspx)
- <http://www.kingmetals.com/Catalog/CatalogListing.aspx?CatalogId=C39&CatalogDetailId=86&ViewAll=true>
- [https://www.google.com/search?q=Aluminum+Hemisphere+PHA&um=1&ie=UTF-8&hl=en&tbn=isch&source=og&sa=N&tab=wi&ei=RpayUL\\_0B6Xa2AWIvIGICQ&biw=1366&bih=651&sei=UpayUO2KHpT9yAHv5oC4Bg](https://www.google.com/search?q=Aluminum+Hemisphere+PHA&um=1&ie=UTF-8&hl=en&tbn=isch&source=og&sa=N&tab=wi&ei=RpayUL_0B6Xa2AWIvIGICQ&biw=1366&bih=651&sei=UpayUO2KHpT9yAHv5oC4Bg)
- [http://www.pastrychef.com/HEMISPHERE-MOLDS\\_p\\_1228.html](http://www.pastrychef.com/HEMISPHERE-MOLDS_p_1228.html)
- <http://handrail-fittings.sharpeproducts.com/viewitems/hemispheres-balls/hemispheres>
- Two 6.5 inch hemispheres with a .4 inch gap between them would be approximately the same as the ellipsoid of slide 58, however the 6.5 inch size is not available off-the-shelf.

### UPDATE:

**It is much better to have a custom form fabricated to the exact dimensions required per slide 37.**

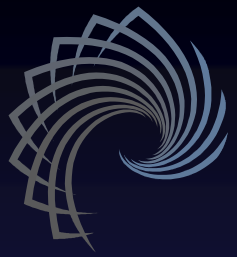

# Design criteria for a prototype continued

## The Ellipsoidal Cavity

- I'm having a hard time finding someone who will make or who already sells the correct size.
- If instead I use 2 hemispheres then these are possible options:

- For 70cm band:

<http://www.lionsdeal.com/te-37160.html>

<http://www.katom.com/296-37160.html>

- For 33cm band:

<http://www.etsy.com/listing/85059084/pair-of-wearever-aluminum-mixing-bowls>

### **UPDATE:**

**It is much better to have a custom form fabricated to the exact dimensions required per slide 37.**

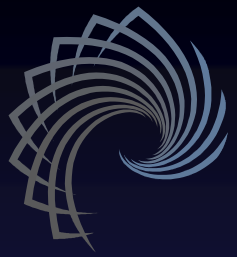

# Resonant cavities revisited:

- A half ellipsoid is easier to work with in a lab environment.
- A magnetic loop antenna at microwave frequencies is not practical so an antenna at foci B can be morphed into a flat RF mirror at the mid point and the total path length between foci would be the same as for a complete ellipsoid.
- The magnetic material can get its initial simulation another way, to be discussed in the following slides.

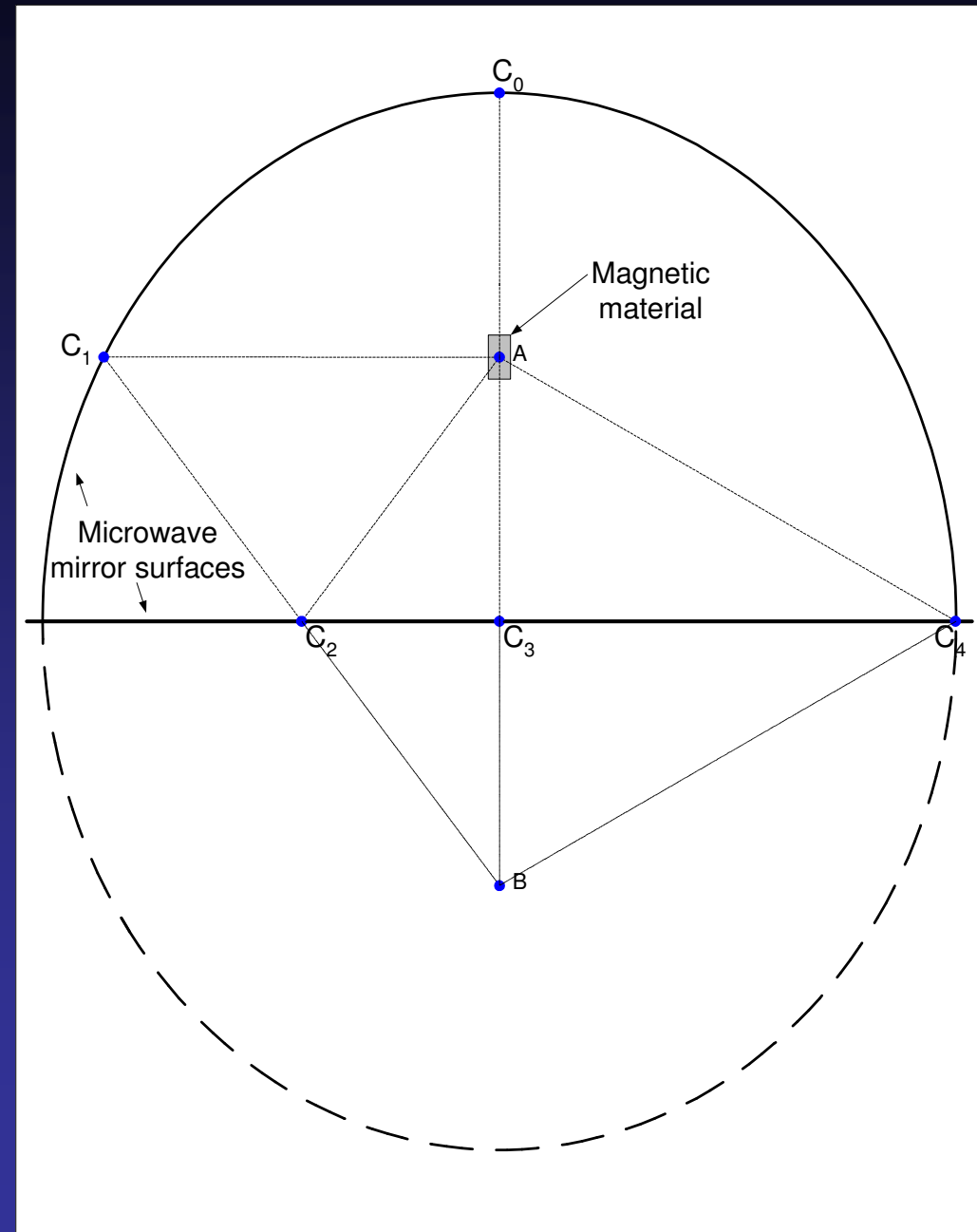

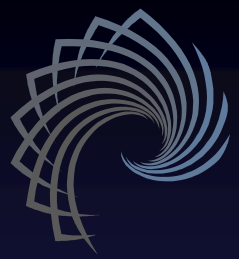

# A semi-ellipsoid resonant cavity

Referring to the diagram below, to get the desired effects from a magnetic material at position A within a semi-ellipsoid on a flat plate reflector, these dimensional requirements must be met:

$\overline{m}$  and  $\overline{n}$  are half wavelength increments: 0, 1/2, 1, 1.5, etc.

$$\overline{C_0A} = (\overline{m} + 1/4) * \lambda$$

$$\overline{AC_3} = (\overline{n} + 1/4) * \lambda$$

$$\overline{AC_4} = (\overline{m} + \overline{n} + 1/2) * \lambda,$$

When these conditions are met then:

$$\overline{AC_1} + \overline{C_1C_2} + \overline{C_2A} = 2 * (\overline{AC_4}) = 2 * \lambda * (\overline{m} + \overline{n} + 1/2)$$

- When the reflections bounce directly back to the foci A from the top or bottom they have a single 180 degree phase shift from the reflecting surface and another 180 degree phase shift from the round trip delay of  $\lambda/2$ .
- When reflecting off 2 surfaces the reflection needs to have an additional  $\lambda/2$  round trip delay.

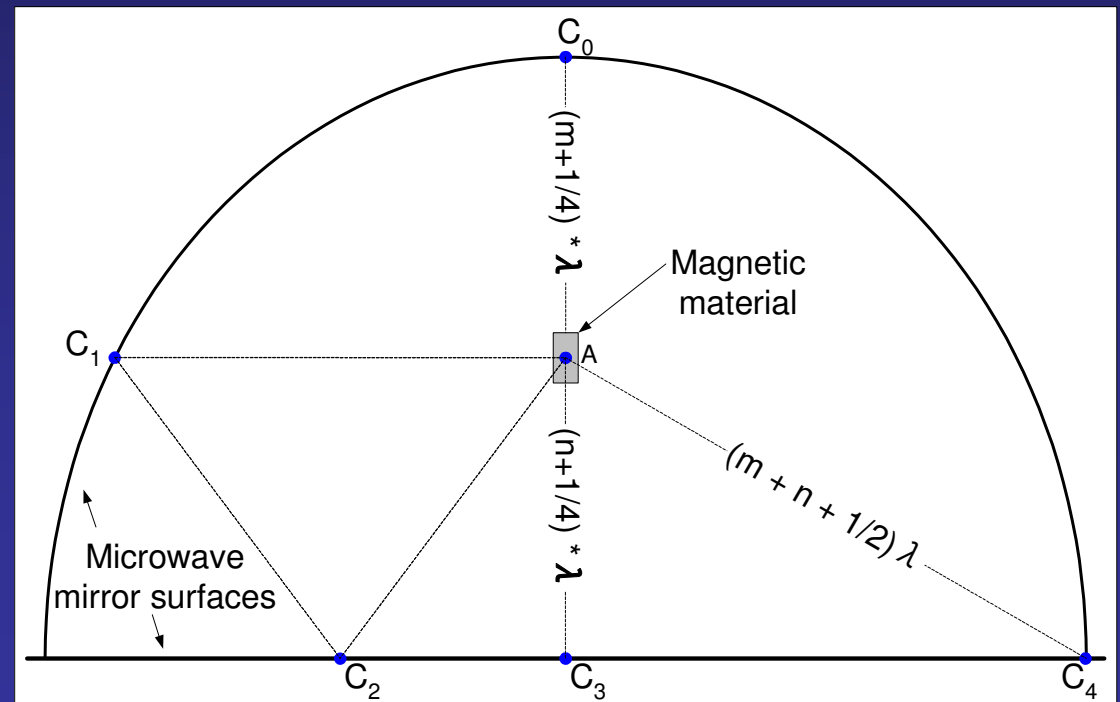

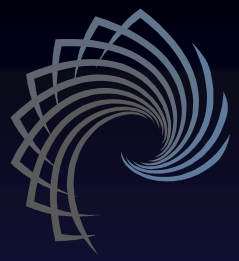

# A semi-ellipsoid resonant cavity

- This is a semi-ellipsoid with  $m=1/2$  and  $n=0$ :

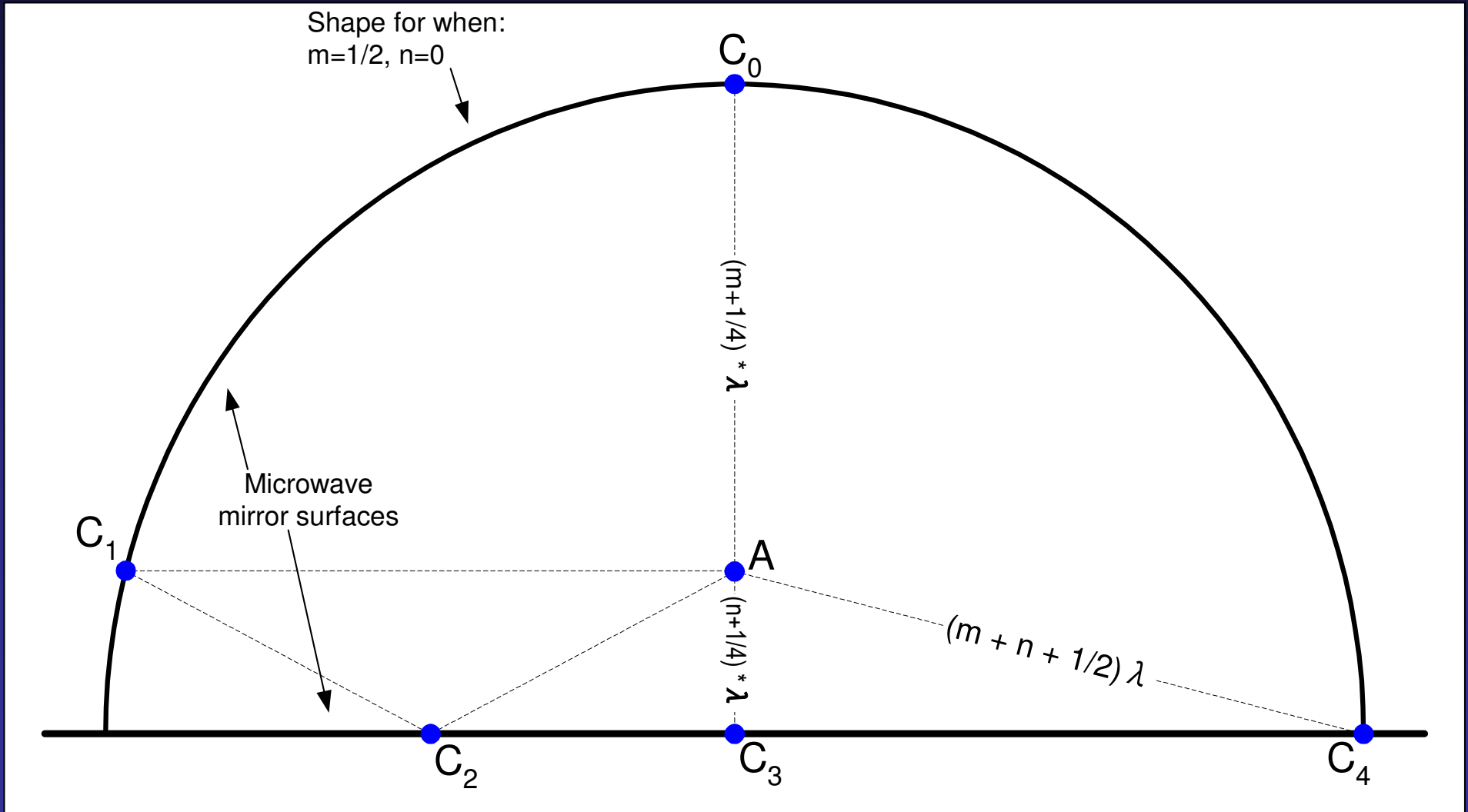

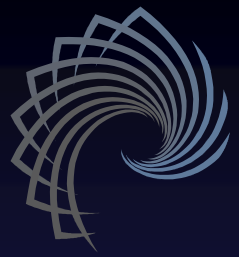

# A semi-ellipsoid resonant cavity

- This is a semi-ellipsoid with  $m=0$  and  $n=1/2$ :

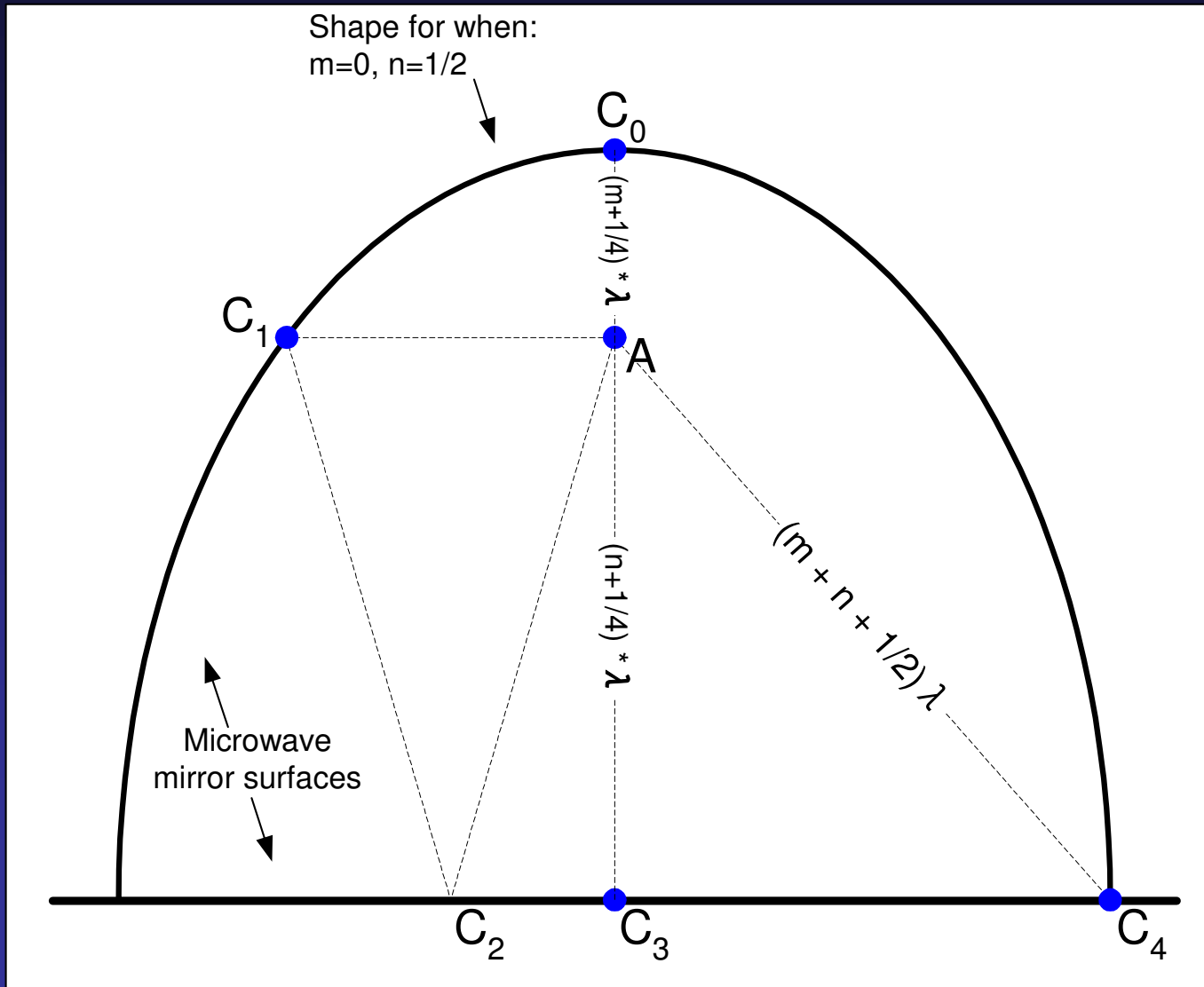

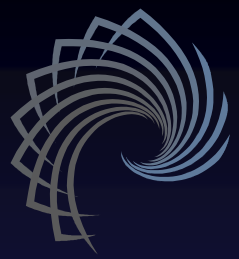

# A semi-ellipsoid resonant cavity

This is a semi-ellipsoid with  $m=n$ :  $m=0$  and  $n=0$ ,  $m=1/2$  and  $n=1/2$ , etc..

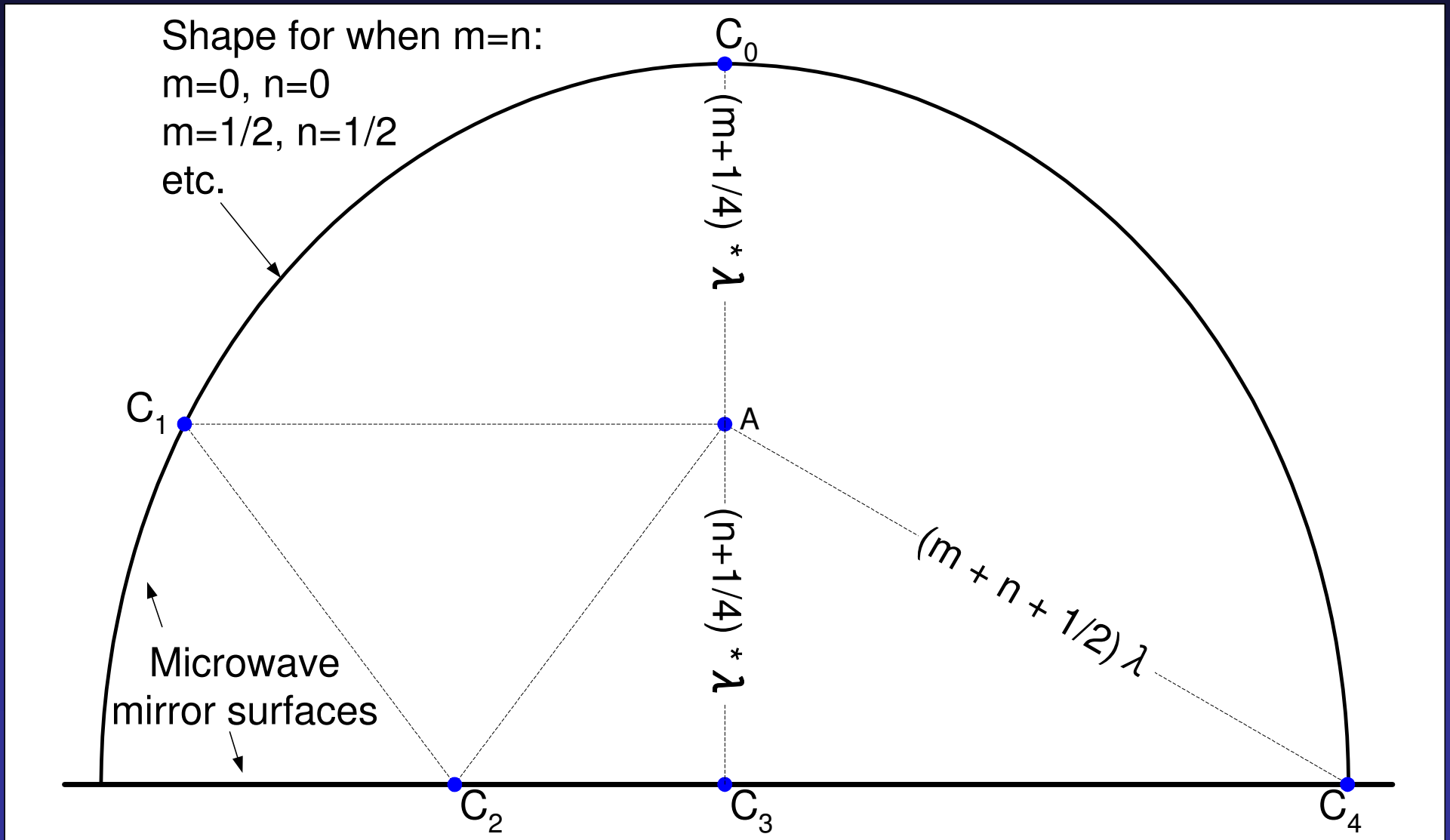

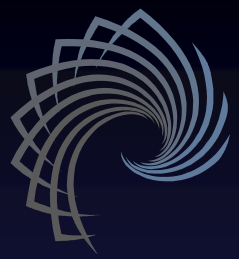

# A semi-ellipsoid resonant cavity

- The magnetic material can get its initial stimulation using microwaves through a circular waveguide.
- Power can be extracted from the magnetic material using the same circular waveguide.

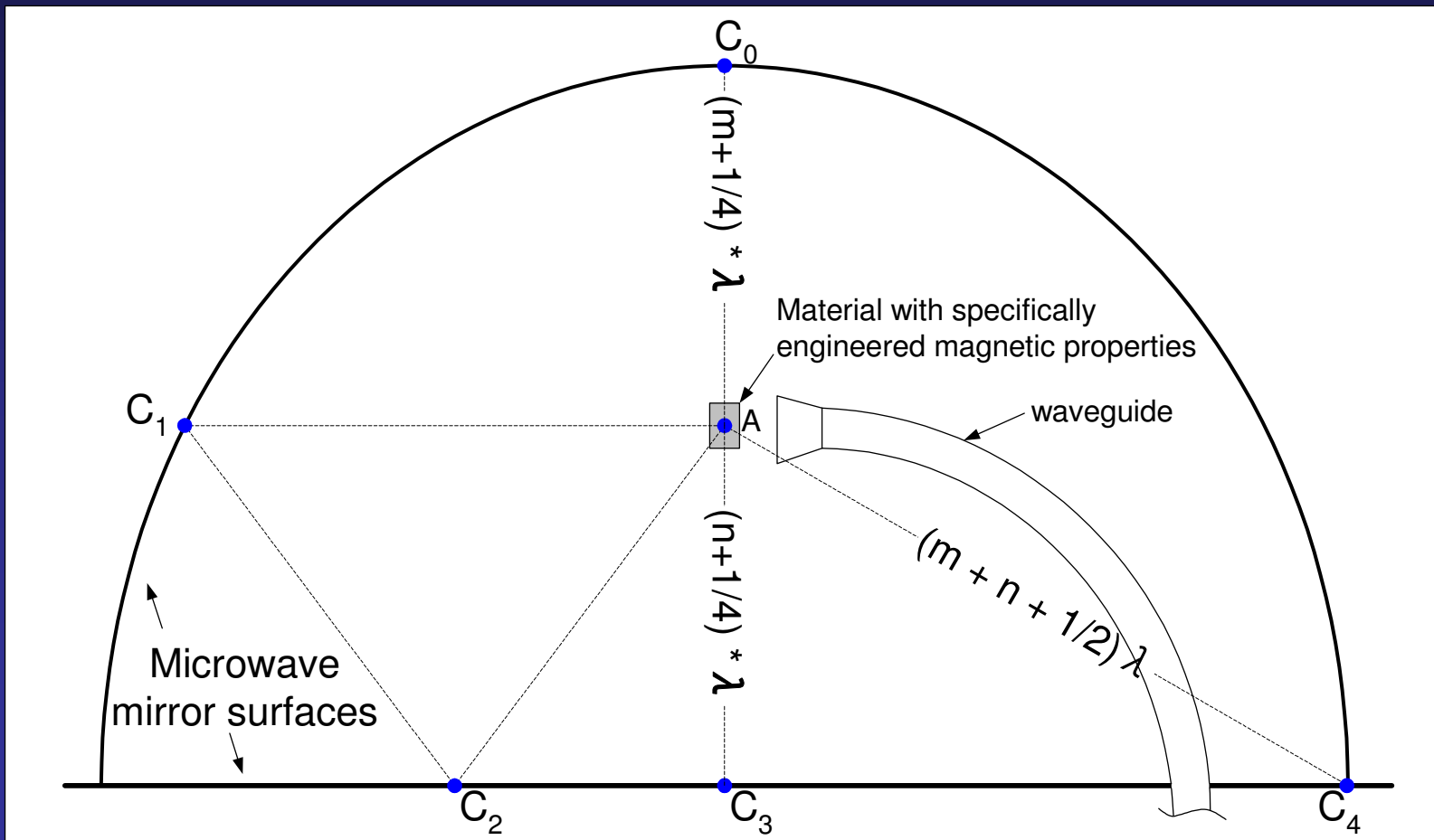

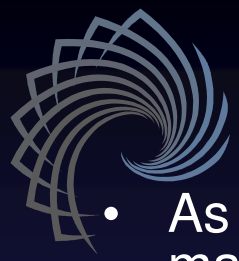

# A semi-ellipsoid resonant cavity

- As discussed earlier, this type of resonant cavity can be used to generate magnetic waves up and down, i.e. in the direction usually considered the “null” direction for radiation of transverse electromagnetic waves.
- We have seen some applications that used a wedge shaped target material.
- This may have been done to add a magnetic “delay line” that utilizes spinwaves within the magnetic material to perform a 180 degree phase shift to the magnetic waves before exiting through the top of the cavity.
- Alternatively, the top of the wedge might be used to sample external magnetic waves and phase shift them before they converge at the focal point.

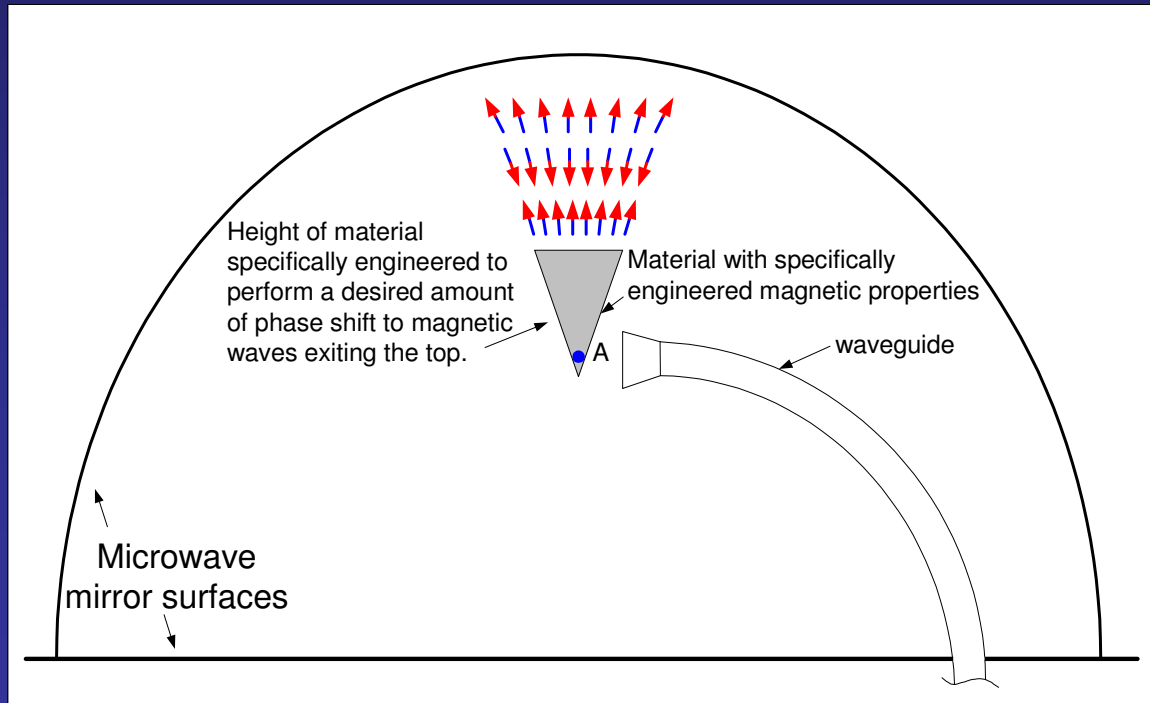

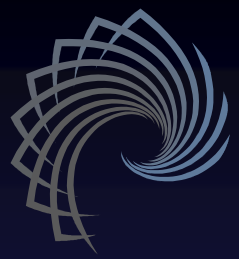

# A semi-ellipsoid resonant cavity

- Referring to examples linked to at bottom, the vertically oriented conical guide might be some type of material to direct magnetic waves downward while allowing transverse electromagnetic waves to pass through to the ellipsoid walls.
- It is this author's contention that no special atomic element is required.
- If the cavity is large enough then self sustained resonance should be possible with "Earthly" magnetic materials; however, materials exhibiting the most desired effects have been purposely kept off the commercial market available to DIY experimenters.
- High relative permeability magnetic materials that work at UHF and microwave frequencies are sold for military applications and it is hard to get their vendors to release specifications.

<https://www.google.com/search?q=lazar+reactor&tbm=isch>

<https://duckduckgo.com/?q=lazar+reactor&t=ffsb&iax=1&ia=images>

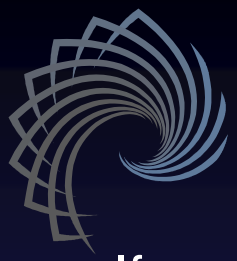

# DIY experimenter recommendations:

- If you want to make your own magnetic materials, manganese based magnets might work, examples, Mn-Al-C, Bismanol or Silmanol.
- Before they were taken off the market, manganese based magnets showed anomalous amplification properties in patents US4290070A and GB2075755A.
- Mn-Al-C magnets can have high saturation magnetization and low coercivity which may be desirable characteristics for this application.
- Examples of Mn-Al-C based magnets:
  - US4051706A
  - US4404046
  - US4342608
  - US4443276
  - US4023991
  - US4133703
  - US3976519
  - US3661567
  - US4042429
  - US3730784
  - US3116181
  - US3194654
  - US5769971
  - US4623404
  - US3591369



# After thoughts:

- Referring to the diagram below and referring to the description of a spinwave (magnon) laser at the Vasant Corporation website, the RF signal from the circular waveguide may stimulate the material in the real permeability ( $u'$ ) direction to magnetize the material back and forth in a horizontal plane so as to maintain emissions from coherent precessional motions of electrons in the vertical direction, i.e. the material's imaginary permeability direction ( $u''$ ).
- A typical laser uses 2 opposing mirrors whereas this form of magnon laser uses the reflecting surfaces of the semi-ellipsoid.

[http://www.vasantcorporation.com/about\\_spin\\_wave\\_lasers.php](http://www.vasantcorporation.com/about_spin_wave_lasers.php)

