

# Mini-Mill - Headstock-> Hi Speed Spindle Drive

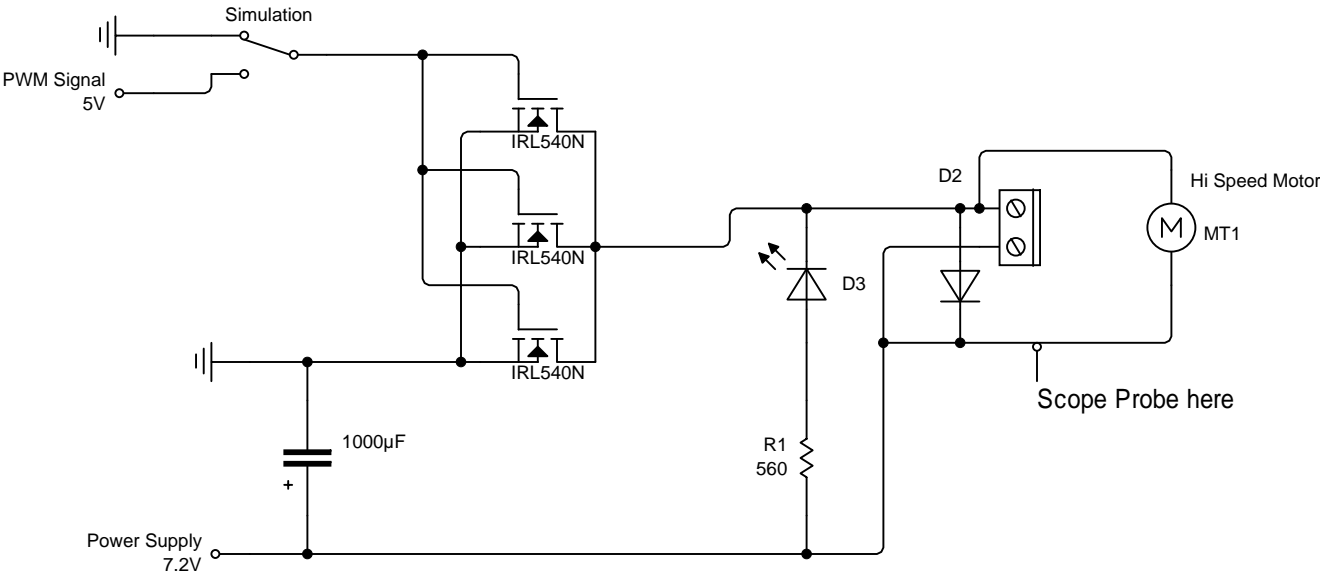

.2 mSec

