

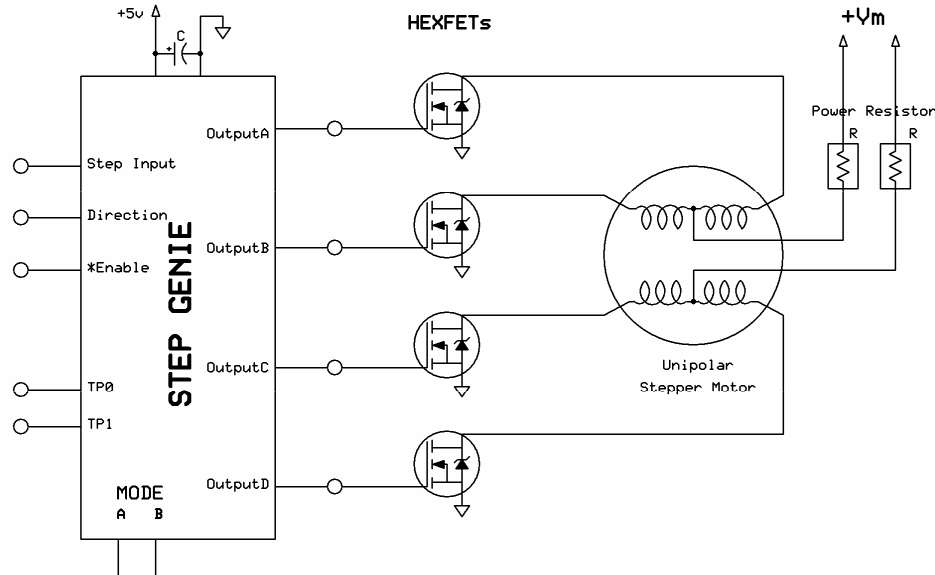

[www.StepGenie.com](http://www.StepGenie.com)

## Introduction

The StepGenie IC generates the sequence of signals required to produce the stepping movement of a stepper motor. These repeating signals occur on 4 outputs lines and advance the motor through one complete step cycle. The four outputs are HEXFET compatible allowing the designer to tailor a power stage to the requirements of the application. A complete high-current unipolar application requires only five external components – four HEXFETs and a bypass capacitor.



There are three useful stepping patterns, which can be represented in tables (*see figure 1*). Advancing forward through the table causes the motor to turn one direction, stepping backward through the table causes the motor to turn in the opposite direction. The command to advance one element in the table (either direction) is called the “Step” signal, while the “Dir” signal specifies which direction. An “Output Enable” signal sets all outputs low, de-energizing the HEXFETs and the Stepper Motor. Mode Input signals (a,b) select the stepping pattern.

The StepGenie provides two diagnostic outputs – TP0 and TP1 which can be used to diagnose (or display by LED) the current status of the device without loading input or output signals.

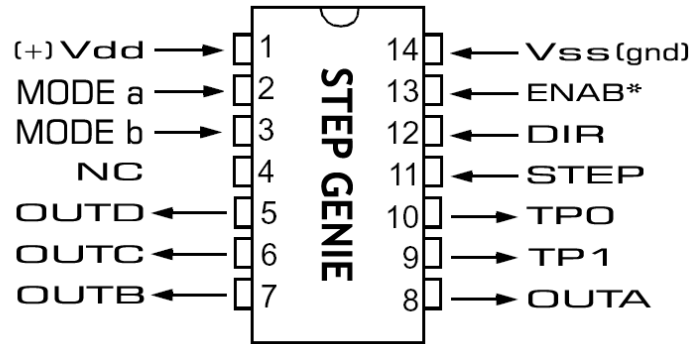

**WAVE-DRIVE SEQUENCE**

Mode a = H, MODE b = L				
Step	OUTA	OUTC	OUTB	OUTD
1	ON	OFF	OFF	OFF
2	OFF	ON	OFF	OFF
3	OFF	OFF	ON	OFF
4	OFF	OFF	OFF	ON

**HI-TORQUE SEQUENCE**

Mode a = H, MODE b = H				
Step	OUTA	OUTC	OUTB	OUTD
1	ON	ON	OFF	OFF
2	OFF	ON	ON	OFF
3	OFF	OFF	ON	ON
4	ON	OFF	OFF	ON

**HALF-STEP SEQUENCE**

Mode a = L, MODE b = H				
Step	OUTA	OUTC	OUTB	OUTD
1	ON	OFF	OFF	OFF
2	ON	ON	OFF	OFF
3	OFF	ON	OFF	OFF
4	OFF	ON	ON	OFF
5	OFF	OFF	ON	OFF
6	OFF	OFF	ON	ON
7	OFF	OFF	OFF	ON
8	ON	OFF	OFF	ON

*Figure 1 – Stepping sequence tables*

## What are HEXFETs?

HEXFETs (a brand name of International Rectifier) are N-Channel Mosfets. This advanced technology has been especially tailored to minimize on-state resistance, provide superior switching performance, and withstand high energy pulse in the avalanche and commutation mode. These devices are well suited for high efficient switched mode power supplies, active power factor correction, electronic lamp ballast based on half bridge topology.



*International Rectifier products shown.*

## **STEP**

A pulse at the STEP input advances one element in the Step table, in the direction determined by the state of the DIR signal. This causes the motor to take a single step. The action is taken at the leading edge (low to high transition) of the step signal. A STEP pulse must have a minimum duration of 3 $\mu$ S. Maximum stepping frequency = 16 kHz.

## **DIR**

The DIR signal specifies the direction to move in the Step table. The state of the DIR signal is clocked in at the the leading edge of the STEP pulse. A HI at the DIR input advances one element in the table, a LO retreats one element in the table. Since the direction a motor turns is dependant on the motor wiring order, clockwise/counter-clockwise is not specified by HI/LO. (One could stipulate that HI indicates clockwise movement.)

## **ENAB\*** (Active LO)

The ENAB\* signal must be LO in order for stepping to occur. When the ENAB\* signal is HI, the four outputs (OUTA,B,C,D) are held LO and no further internal advancing in the step table occurs. The effect of all four outputs LO (a state that does not occur in the stepping tables) is to de-energize the motor. While the ENAB\* signal could be tied LO, it is generally desirable to de-energize the motor after a period of inactivity, to prevent possible motor overheating. Thus the ENAB\* signal should be held LO for all stepping action and brought HI after a period of inactivity.

## **OUTA, OUTB, OUTC, OUTD**

***NOTE: The StepGenie IC cannot directly drive ANY motor. Output current is limited to 25ma.***

These are the motor control output lines. The state of these these outputs is determined by the current position in the stepping table (see stepping tables), the Stepping Mode and the ENAB\* input. For a Unipolar application these outputs can directly drive HEXFETS (N-Channel MOSFETS). A variety of HEXFETs are available from International Rectifier and other manufacturers. (IRL530, IRF540, IRFR3504, IRFP3306, etc.) Protection diodes are not required when using HEXFETs. If using older technology Darlington Transistor, protection diodes should be used.

OUTA, OUTB are assumed terminals of one motor coil. OUTC, OUTD are terminals of the other coil. Given this convention, the “firing order” is ACBD for the basic wave-drive sequence not ABCD. Note the order of the Stepping Table column header is ACBD not ABCD.

It is also possible to create a bipolar output stage, but that requires additional external circuitry and is not covered here. (StepGenie IC's with inverted outputs are available by special request.)

### **MODE a, MODE b**

These two inputs specify the stepping pattern: Wave Drive, High Torque, Half Step.

[a=1,b=0] Wave Drive (Single coil, 4-step pattern)

[a=1,b=1] High Torque (Double coil, 4-step pattern)

[a=0,b=1] Half-Step (Mixed, 8-step pattern)

[a=0,b=0] Reserved.

If left unconnected, these inputs float high and the mode is High Torque.

### **VDD(+), VSS(gnd)**

Power to the IC is applied at these two pins. Recommended operating voltage is 5 volts.

A bypass capacitor between these two pins is required. Locate the capacitor near the IC. A 10uF (50v) electrolytic is recommended for general application. (Respect polarity of electrolytic capacitors.)

Design Note: A smaller 0.1 uF ceramic can be used instead, as long as the motor supply is properly bypassed with a suitable electrolytic. Use of the 10uF is recommended for experimentation, in case the motor power supply happens to share the same 5v supply and the designer forgets to bypass the 5v supply.

### **TP0**

This diagnostic output tracks the ENAB\* signal. If this signal remains HI, it's an indication that the ENAB\* signal is not being received. When this signal is HI, all outputs are LO and no stepping occurs. An LED connected to this output will show when the motors are being energized.

### **TP1**

This signal goes HI during step 1 of the stepping pattern and returns LO thereafter. (In halfstep mode the signal remains HI for step 2 also.) It can be used as a 'sync' signal indicating step 1 of the pattern, or as a visual indicator of stepping. If an LED is connected to this output it will appear to flash at ¼ the stepping rate. Note that if stepping happens to stop at step 1 of the pattern this signal will remain HI.

## **Allegro UCN5804b vs Steptronics 'StepGenie'**

The Allegro 5804b was a robust Stepper Translator IC with built-in Drivers. Its simple 3-signal interface [Step, Dir, Enable] and choice of three stepping modes made it popular with hobbyists. Unfortunately, this device has been discontinued. The limitation of the 5804 was its low current drive capability. It can only drive motors up to 1.25 amps per phase.

The StepGenie shares the design philosophy of the 5804 – a simple interface, and robust performance requiring few external parts. The control signals and stepping modes of the two devices are identical. The StepGenie, however, can drive much much larger motors because the driver section is brought outside the chip, allowing it to cope with much higher currents. Where the 5804 has a limit of 1.25 amps per phase, the StepGenie current drive is limited only by the choice of external HEXFETs. A typical low-cost HEXFET has a current rating of 15 amps (This spec assumes heatsinking, without no heatsinking 5 amps per phase is easily achievable.) Recently introduced HEXFETs have a current rating (with heatsinking) of 200 amps!

The 5804 requires 5 external components – a bypass capacitor and 4 protection diodes. The StepGenie requires 5 external components – a bypass capacitor and 4 HEXFETs.

HEXFETs (N-Channel MOSFETs) are extremely efficient - more so than the older Darlington technology, which also require protection diodes on the outputs.

The outputs of the StepGenie are compatible with HEXFETs and can drive them directly. No intermediate components or protection diodes are required.

The StepGenie provides two output signals not found on the 5804 – TP0 and TP1. These can be used to diagnose (or display with LED) the current status of the device without loading the input or output signals.

Although the interface and timing of the two devices are the same, the StepGenie is *not* pin compatible with the 5804. It is, however, a very good replacement. The StepGenie can drive much larger motors and provides two output signals not found on the 5804.

## **StepGenie vs PIC**

Although stepping patterns can be programmed in a PIC, most PIC solutions are not satisfactory due to slow response/lag times between the step command and the actual change of the output signals. The effect can be system lag, or variation in response time which creates an uneven pulse train, resulting in motor jitter.

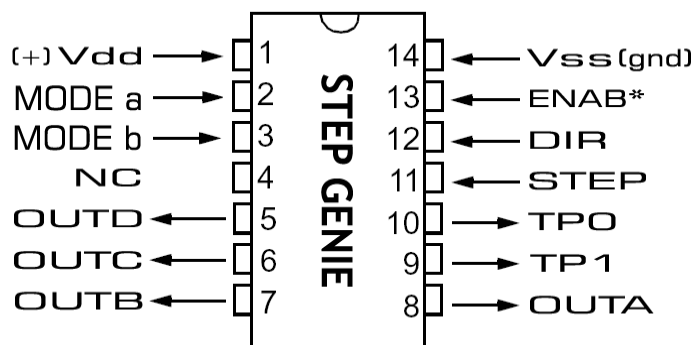

Sym	Characteristic	Min	Typ	Max	Units	Conditions
VDD	Supply Voltage	4.5	5.0	5.5	V	
	Input Low Voltage	VSS		0.8	V	
	Input High Voltage	2		VDD	V	
	Output Low Voltage			0.6	V	
	Output High Voltage	VDD -0.7			V	
IDD	Supply Current		340	450	$\mu$ A	

## 12.0 ELECTRICAL SPECIFICATIONS

### Absolute Maximum Ratings

Ambient temperature.....	-40 to +125°C
Storage temperature .....	-65°C to +150°C
Voltage on VDD with respect to VSS (GND) .....	-0.3 to +6.5V
Voltage on all other pins with respect to VSS (GND).....	-0.3V to (VDD + 0.3V)
Total power dissipation .....	800 mW
Maximum current out of VSS (GND) pin .....	300 mA
Maximum current into VDD pin .....	250 mA
Input clamp current .....	+/- 20 mA
Output clamp current .....	+/- 20 mA
Maximum output current sunk by any I/O pin.....	25 mA
Maximum output current sourced by any I/O pin .....	25 mA
Maximum current sunk by ALL outputs (combined) .....	200 mA
Maximum current sourced ALL outputs (combined) .....	200 mA

## FEATURES

Wave-Drive, High Torque, and Half-Step Drive Formats  
 Output Enable and Direction Control  
 Power-ON Reset  
 HEXFET compatible outputs  
 Diagnostic Output signals



[www.stepGenie.com](http://www.stepGenie.com)