

# FLOOD WARD

By Romeo Gheorghian

When leaving in holidays, the house may remain without supervision for a time and some safety devices are useful to prevent unpleasant things that may occur, like plumbing problems, especially when it has reinforced rubber hoses with thin terminations, which have a not very high endurance. The device described below closes automatically the water supply of the house and generates an optical and a sound advertising signal, when detects accidental water leakages, limiting some unpleasant consequences. When leaving in a block house, the little investment is really worth full, especially considering the neighbors living below.

The device may be used also for different purposes, like for turning off a pump or the water supply when, for example, a tank becomes full.

To make this device effective, some electromagnetic valves must be mounted in series with each incoming water supply pipe of the house, like the type pictured in Fig 1, having a coil wound for AC supply, corresponding to the existing wall socket voltage. In order to minimize the long term energy consumption, the electromagnetic valve must be a normally open direct operated type, which should support the maximal water pressure which can appear and having a passing orifice big enough in order to not diminish significantly the required water flow. Usually, a nominal 6 Barr and 4 - 6 mm orifice electro valve can be used, which can have also 2 or more ways and two positions, with at least one normally open way, the other unused connections should be blinded. If the water pressure is higher, a indirect open electro valve should be used, which usually is made to operate at high pressures, but having the disadvantage that needs for opening a minimal pressure, like 0,5-1 Barr.

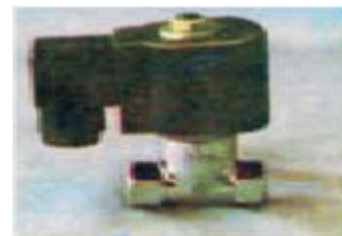

Fig. 1

To detect water leakages, some simple wire-made water sensors like the one described in Fig.2, must be placed on non conductive surfaces, in the lowest positions of the rooms (on the floor) anywhere accidental water wastes may occur like under the sinks, boilers and in bathrooms. All sensors must be connected in parallel. Considering that the voltage present at the sensors is not dangerous for the human body (24V DC, limited at 0,5 milliamps) and it is completely isolated from the line, no protection caution is required more than connecting the grounding circuit and the case of the device to a good earth connection. When the environment touched by the sensor ends becomes wet, the electrical resistance between the wires decreases from more G-ohms to kilo ohms, determining the device to detect a water leakage. The schematic of the device is given in Fig.3.

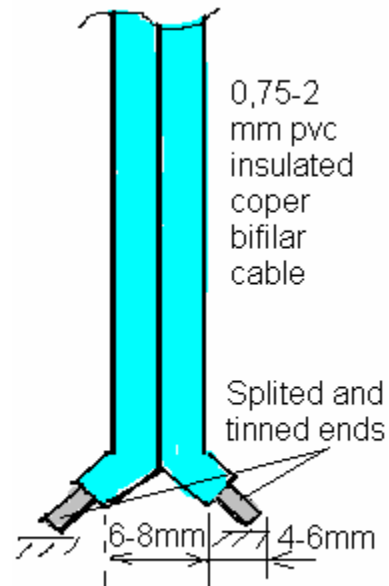
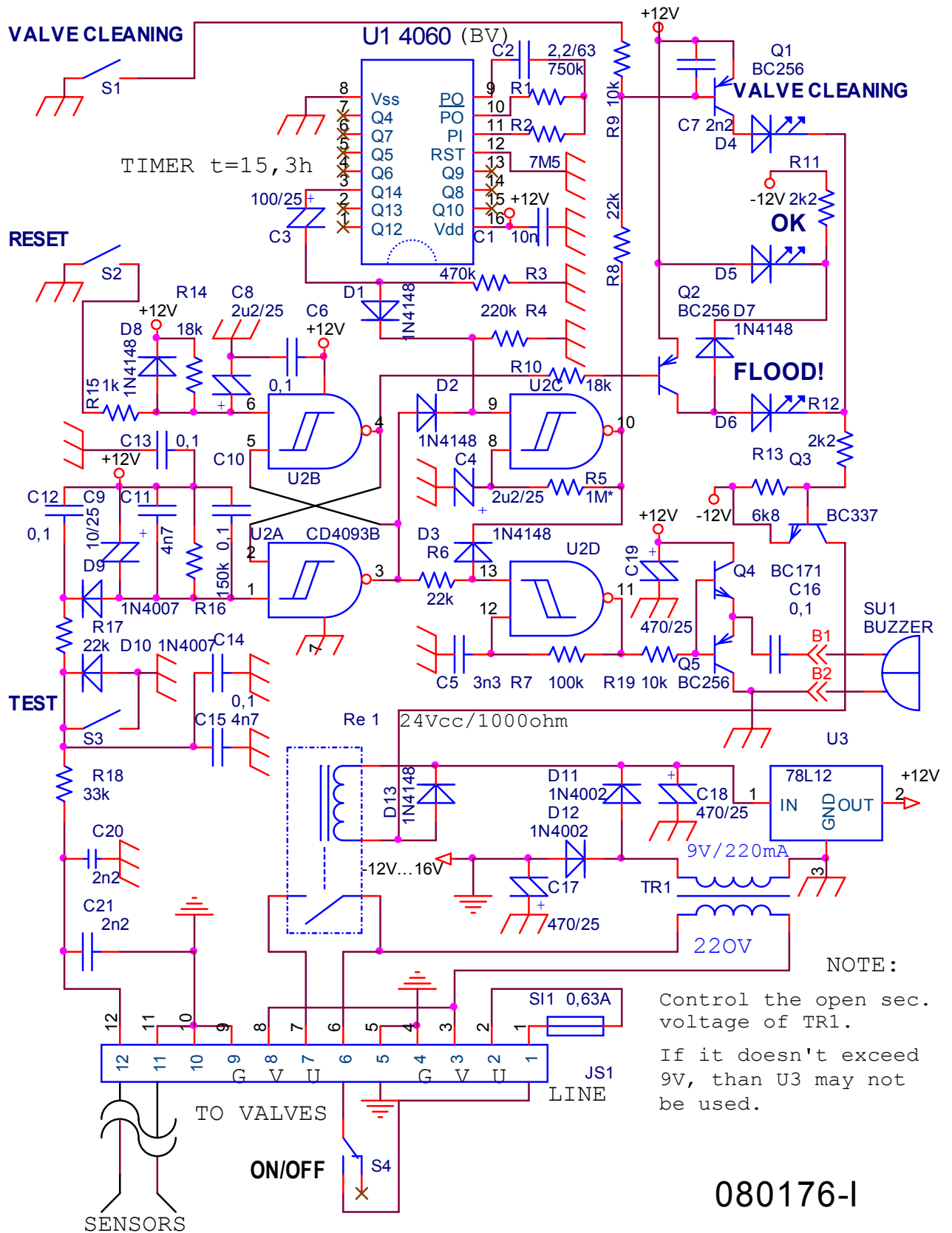

Fig.2

The power supply of the device contains a low power transformer, which delivers 9VAC, by means of two diode rectifiers (D11, D12) and filter capacitors (C18, C17)



being obtained approximately +12V and -12V. If the open secondary voltage of the transformer exceeds 9V (that happens to very low power transformers), in order to

prevent the overvoltage of the CMOS integrated circuits, a LM 78L12 – U3, may be optionally used. The negative DC voltage is connected directly to the ground circuit (earth) and to a wire of each sensor used. When inserted in water, any sensor will negativate the 1 input of the U2A gate by means of the low water resistivity, determining the output 3 switching to 1 logic and 4 to 0. The 1 logic of the U2A output enables an astable multivibrator which generates a frequency around 1kHz, which is converted to sound by a piezoelectric buzzer, driven by Q4-Q5. Simultaneously, through D2, an other astable multivibrator is enabled, using the gate U2C, oscillating at a frequency around 0,8 Hz, which makes the beeping intermittent. The gates U2A and U2B form a R-S bistable circuit, by means of C8 and C9 being jammed at start-up to hold the output 3 at 0 logic and 4 to 1 logic, when no sensor touches a wet environment. In this case, The LED D5 (blue) is lighted up. When a resistance less than 50 kilo ohms appears between the sensor wires (caused by water) the bistable U2A-U2B is set, and opens the Q2 transistor, which lights the D6 red led, opening also the Q3 transistor, which energizes the coil of the Re1 relay, who actuates the electro valves, closing the water supply of the house. When each sensor becomes dry, by pressing the S2 push-button the bistable is reseted and the electro valves will be opened again. To prevent the effect of electromagnetic fields, like from cell-phones a filtering circuit is used, between the sensor circuitry and the bistable (C9-C12, C14-C15, C20-C21, R17 and R18).

When the electro valves rest for a long time not actuated, being traversed by water, there are big chances to not operate anymore, because of the depositions accumulated. To prevent this, a timer with a CD4060 is used, which delivers pulses with a period of approximately 15 hours. The pulses are derivated using C3, D1, R3 and R4, and applied to the 9 input of the U2C astable, through a diode OR circuit, which enables this astable for approximately 4 seconds (depending on the C3 capacity and R3-R4 values). This makes that every 15 hours the electro valves being actuated, 3 or 4 times, preventing the deposition accumulating. The valves can also manually being actuated, pressing the S1 push-button. When this occurs, the D4 green LED is lighted. For testing or manually water supply closing, the S3 push-button is provided.

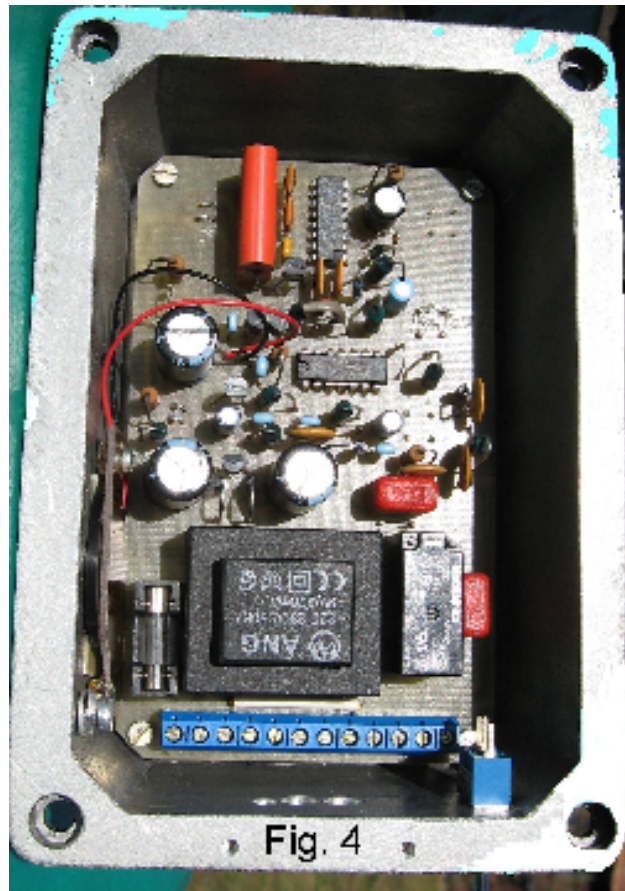

## Bill Of Materials

Item	Quantity	Reference
1	1	C1 10n
2	1	C2 2,2/63
3	1	C3 100/25
4	2	C4,C8 2u2/25
5	1	C5 3n3
6	6	C6,C10,C12,C13,C14,C16 0,1
7	1	C9 10/25
8	2	C15,C11 4n7
9	3	C17,C18,C19 470/25
10	2	C20,C21 2n2
11	1	C7 2n2C
12	6	D1,D2,D3,D7,D8,D13 1N4148
13	2	S1,D4 LED, Green
14	1	D5 LED, Blue
15	1	D6 LED, Red
16	2	D10,D9 1N4007
17	2	D11,D12 1N4002
18	1	JS1 CONN TRBLK 12
19	3	Q1,Q2,Q5 BC256
20	1	Q3 BC337
21	1	Q4 BC171
22	1	R1 750k
23	1	R2 7M5
24	1	R3 470k
25	1	R4 220k
26	1	R5 1M*
27	3	R6,R8,R17 22k
28	1	R7 100k
29	2	R19,R9 10k
30	2	R10,R14 18k
31	2	R12,R11 2k2
32	1	R13 6k8
33	1	R15 1k
34	1	R16 150k
35	1	R18 33k
36	1	SI1 0,63A
37	1	SU1 Piezoelectric BUZZER
38	3	S1, S2, S3 Push-buttons
39	1	S4 Switch, 3A-220VAC
40	1	U1 4060
41	1	U2 CD4093B

42	1	U3	78L12
43	1	Re1	Relay 24Vcc, 1000 ohm coil, 5A / 220Vcontacts