

chapter 10

voltage controlled amplifier (VCA)

This chapter continues the discussion of the tone-forming circuits with a description of the Dual VCA module, which can be used in conjunction with the envelope shaper for dynamic control of signal amplitude, and also for periodic amplitude modulation of the signal waveform (tremolo).

The voltage controlled amplifier module is called a 'Dual VCA' because it contains two cascaded, but independently controlled, amplifiers. The gain of the first amplifier is voltage controlled via an exponential converter, and is used for envelope shaping. The second has a linear gain-control input and is used for periodic modulation of signal amplitude (tremolo). The VCA is provided with a modulation indicator, which allows the best compromise to be obtained between signal-to-noise ratio and overload margin.

Connection of the VCA in the synthesiser system

Figure 1 illustrates how the VCA fits into the synthesiser system. The VCA takes its input from the output of the VCF, which in turn takes its input signal from the VCOs.

The VCF and VCA can both be controlled by the ADSR envelope shapers, so allowing dynamic variation of tone colour and amplitude during the playing of a note. However, the VCF has a KOV input from the keyboard to allow it to function as a tracking filter, but the VCA lacks this, since there is no pitch related control of signal amplitude.

Using the VCA and the VCF

It may be interesting at this point to spend a little time comparing and contrasting the effects produced by the VCA and VCF, and discussing how they are used to complement one another in the synthesiser system. As an example, consider the case where the VCA and VCF are both controlled by the same waveform from the envelope shaper, consisting of a rapid attack and a relatively slow exponential decay, as shown in figure 2a, and are fed with a 440 Hz sawtooth waveform.

If the VCF is used alone in the lowpass mode and the cutoff frequency of the

filter is initially set very low, the input signal will be completely suppressed. However, during the attack phase of the envelope control waveform the cutoff frequency of the filter will rise very rapidly, and the amplitude and harmonic content of the note will both increase as first the fundamental, then the harmonics, are passed. During the slow decay phase the note will die away slowly as the cutoff frequency falls, starting with the higher harmonics, then the lower harmonics, and finally the fundamental. The variation in turnover frequency of the filter is illustrated in figure 2b.

The tone thus produced is not unlike that of a clavichord, or of a piano which has had drawing pins stuck into the hammers to produce a jaggy, honky-tonk effect.

If the same signal and control waveforms are fed to the VCA, the signal amplitude will rise rapidly as the gain increases during the attack phase, and will fall away slowly during the decay phase. However, the harmonic content of the signal will remain unaltered. The sound thus produced is similar to that of percussion instruments such as the piano and xylophone.

By varying the attack and decay times of the envelope shapers a wide variety of tone colour and amplitude dynamics can be produced using the VCF and VCA in conjunction.

VCA design considerations

The dual VCA contains two amplifiers whose gains are independently voltage-controllable, and the design of the VCA poses certain problems, the principal one being that of obtaining adequate dynamic range, as is illustrated in figures 3a to 3d.

Figure 3a shows a control contour from the envelope shaper. At the peak of the control contour the VCA must have a finite maximum gain, which, for the purposes of the discussion, it will be assumed is unity, or 0 dB. At the beginning and end of the note the signal must be inaudible, which means that the gain of the amplifier should ideally be infinitesimally small at these moments in time. In practice, if the gain is around -70 dB then this will be adequate.

What happens if the dynamic range is inadequate is shown in figure 3b. Suppose the gain of the amplifier can be varied by a range of only 40 dB or so, and is set to 0 dB on the peak of the control contour. At the start and end of the note the signal will only be 40 dB down, and if the note is being played fortissimo then this residual signal will still be quite audible.

Another fault of badly-designed VCAs is illustrated in figure 3c. In this example, the VCA cuts off completely below a certain level of control voltage, and so misses part of the attack and decay period of the note. This might be said to be the opposite fault to that of

figure 3b, though it is not directly related to dynamic range, but rather to extreme non-linearity of the control characteristic.

Returning to the example of the VCA with only 40 dB dynamic range, if the gain is adjusted so that the signal is inaudible at the beginning and end of the note (i.e. some 70 dB down), it will only be able to increase by 40 dB when the control voltage is applied, instead of the 70 dB required to reach the 0 dB level. The result is an amplitude plateau, as shown in figure 3d.

As mentioned briefly earlier, control of the envelope shaping section of the VCA is carried out exponentially. This is to compensate for the logarithmic loudness response of the human ear. On the other hand control of the periodic amplitude modulation section (tremolo) is linear, since this gives the 'softest' and 'sweetest' sound to the tremolo effect.

Principle of the Formant VCA

The VCA in Formant uses the CA3080 OTA as the controllable amplifier, as in the VCF. The principle of the Formant VCA is illustrated in figure 4. The input voltage U_i is converted to a proportional output current $I_o = g_m \cdot U_i$. However, since we are interested in voltage amplification this output current must be converted into an output voltage, and this is done simply by feeding the current through a load resistor R_L to produce an output voltage $U_o = g_m \cdot U_i \cdot R_L$.

The transconductance of the amplifier, g_m , may of course be varied by a control current I_{ABC} , as explained in chapter 6, and the gain of the VCA may thus be controlled - although at this stage of course it is a CCA!

The output of the OTA may not drive any external load in addition to R_L , as this would lower the load impedance and alter the gain, so the output of the OTA is connected to a voltage follower/buffer with a high input impedance.

Both sections of the VCA operate on the same principle. However, only the output of the second OTA is buffered, since it is this output that is connected to any external loads. As the output of the first OTA has no external connection it is simply connected to the input of the second OTA.

The OTA has one disadvantage that cannot be ignored. As mentioned in the previous chapter, its linearity is good only for small input signals (typically ± 10 mV) which is why a large degree of input signal attenuation is required. This means that the signal-to-noise ratio is not exceptionally good, and for this reason it is best to use the VCA with the largest possible input signal consistent with low distortion. A modulation indicator is provided, which allows the best compromise to be obtained between excessive noise, at low input levels, and distortion at high input levels.

Figure 1. Block diagram illustrating how the VCA fits into the Formant synthesiser system.

Figure 2. Envelope control of the VCF and VCA. The attack-decay contour of figure 2a, when applied to the VCF, varies the turnover frequency of the filter, which provides dynamic alteration in the tone colour of the sound (figure 2b). When applied to the VCA, the envelope contour alters the gain of the VCA, and thus the amplitude of the sound (figure 2c).

Circuit of the VCA

The complete circuit of the VCA is given in figure 5. The exponential converter built around IC1 and IC3 will immediately be recognised, since it is very similar to that used in the VCF. The input configuration, however, is much simpler, there being but one external input, ENV, from the envelope shaper. If required this can be switched out by setting S1 in position 'a', in which case a fixed gain results.

The gain/control voltage characteristic of the VCF is roughly 12 dB/volt, but as the use of the word 'roughly' suggests, the accuracy of this characteristic is relatively unimportant, unlike the octave/volt characteristics of the VCO and VCF. The ear is much less critical of amplitude errors than it is of frequency errors. The dB/volt characteristic of the VCA may be adjusted by P2, whilst P1 is an offset trimmer. The output current of the exponential converter controls the gain of the first OTA, IC6.

The linear voltage-current converter is constructed around IC2, which is connected as an inverting, summing amplifier. An input signal may be fed to P4 via the AM input socket, and a DC input voltage is available from P3 ('Gain'). Both these input voltages cause proportional currents to flow through R12 and R13, and since these currents cannot flow into the inverting input of the op-amp they flow round the feedback loop through T1, and into the control input of IC7.

The audio signal to the VCA comes either from the permanently wired internal signal input (IS) or from the external signal socket (ES) on the front panel of the VCA module. The amplitude of the external input signal is controlled by P5, whereas the amplitude of the internal signal is controlled at the IOS output of the VCF, by P6 of the VCF module.

IC4 functions as a summing amplifier with a gain of -1, and the signal level at the output of IC4 is monitored by the modulation indicator constructed around IC5. This is a non-inverting amplifier feeding a bridge rectifier D1 to D4, the output of which drives the modulation indicator LED D5. Once the

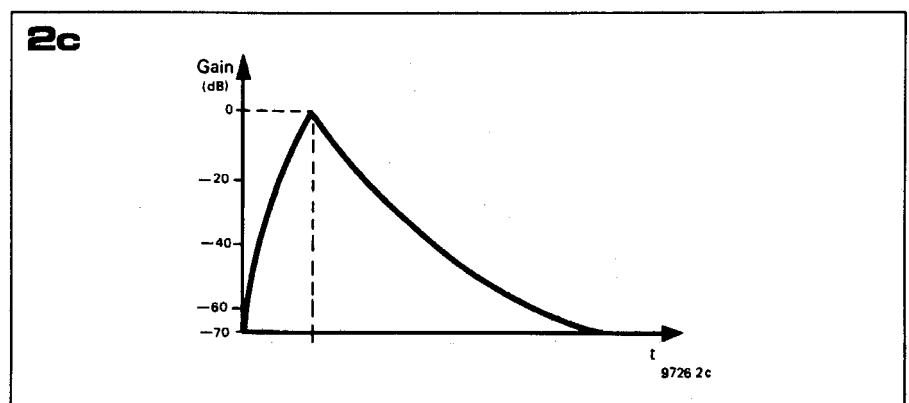
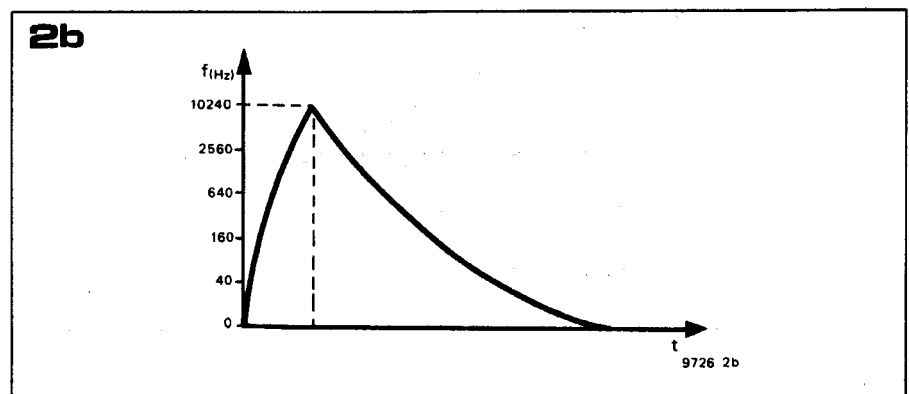
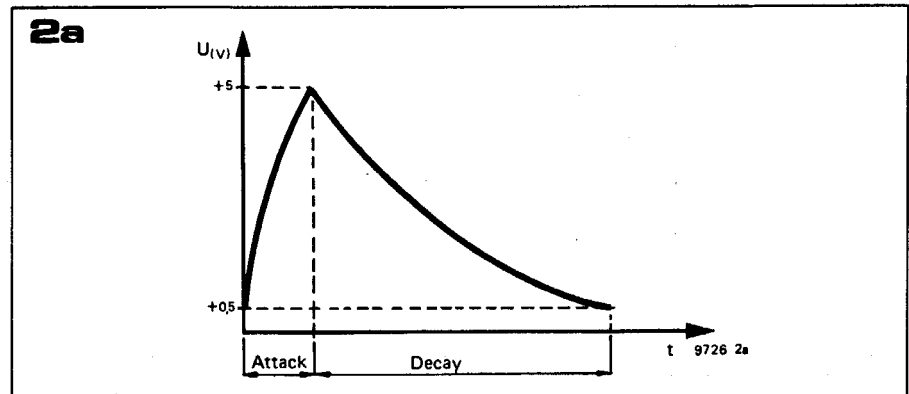
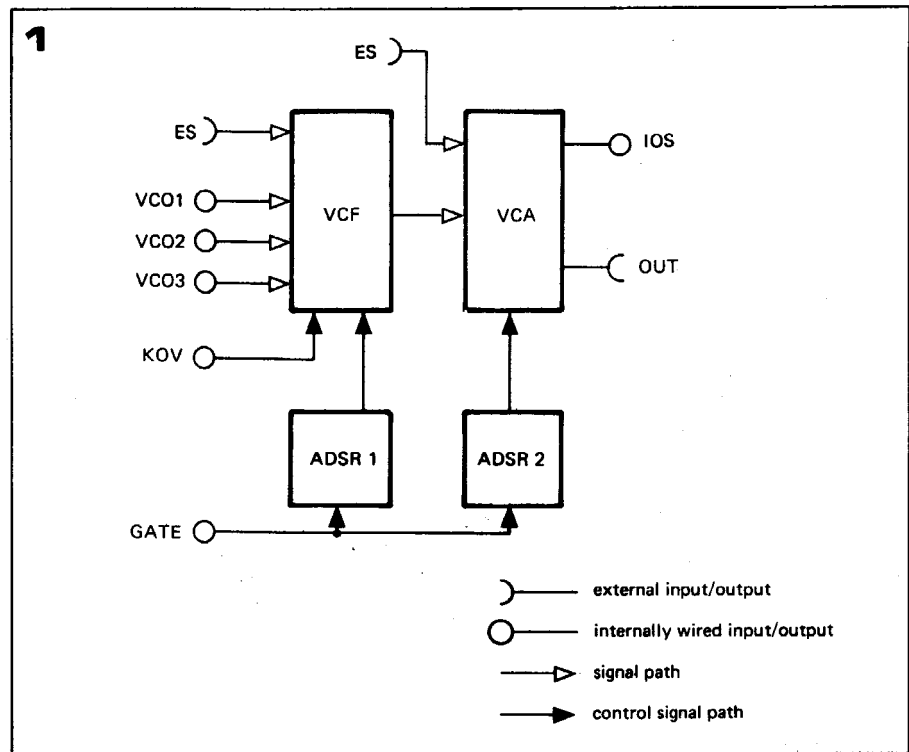

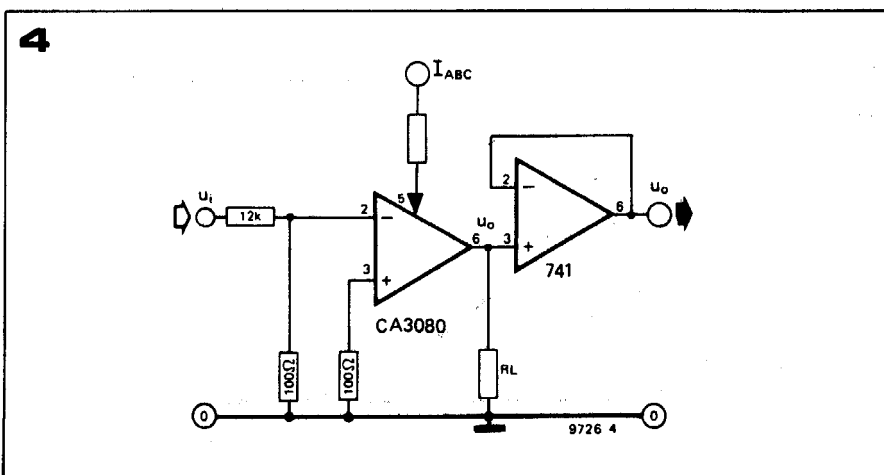
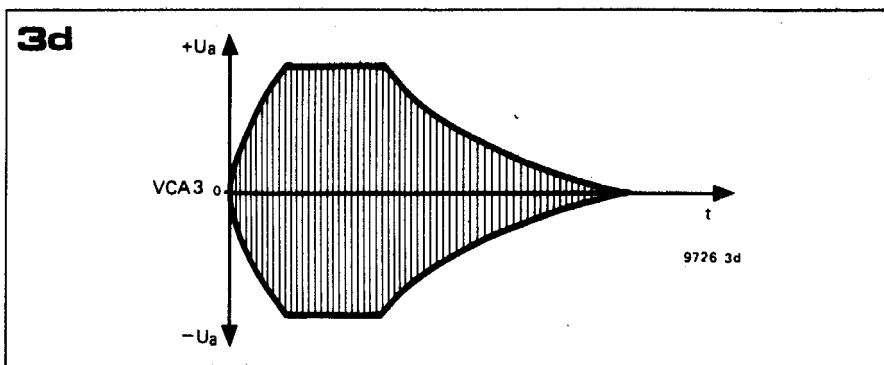
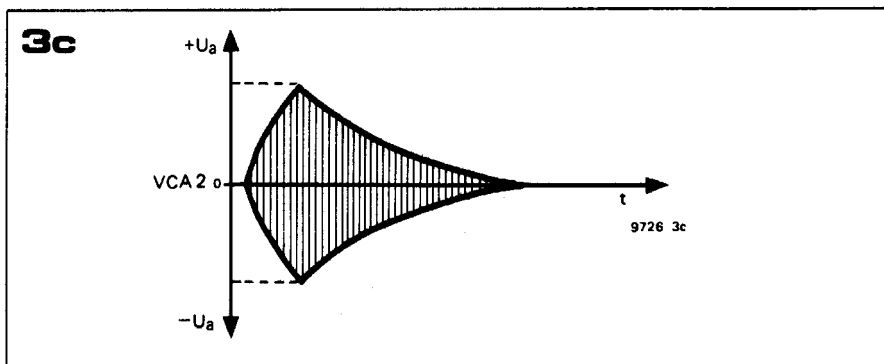
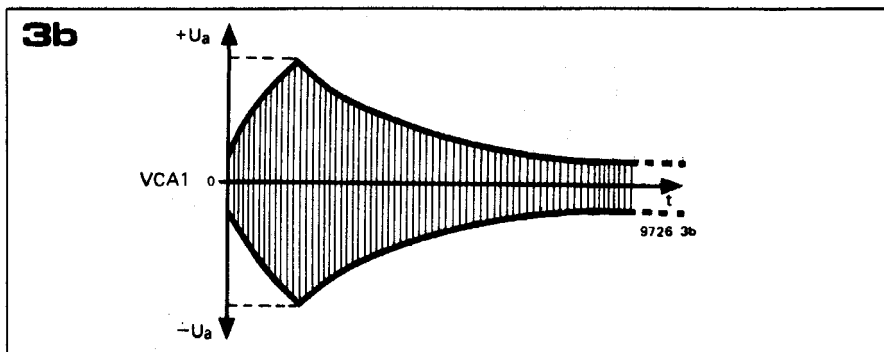
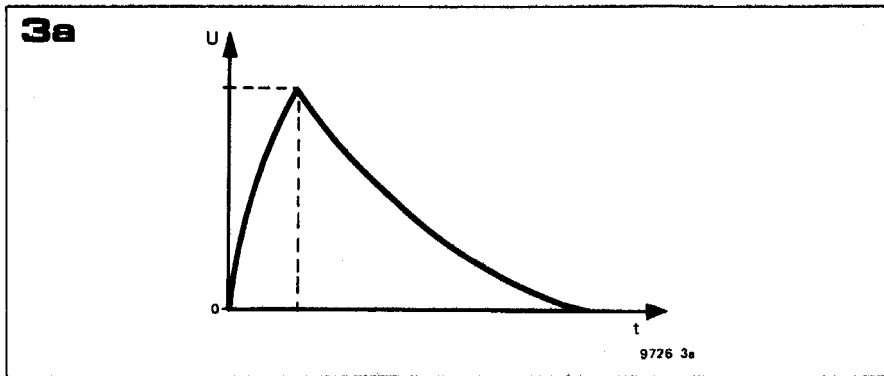

peak signal level at the output of IC5 exceeds the combined knee voltages of D1 plus D5 plus D4 (or D3 plus D5 plus D2) then the LED will start to glow and will glow brighter as the signal level increases. P6 is used to adjust the gain of IC5 so that D5 starts to glow at the signal level where overmodulation begins to occur.

The output signal from IC4 is attenuated by R19 and R20 down to a level which the OTA, IC6, can handle. The output of the exponentially controlled OTA, IC6, is fed via a second attenuator R25/R26, to the input of the linearly-controlled OTA, IC7. The output of IC7 is buffered by voltage-follower IC8 and two outputs from the VCA are provided, an internally wired output, IOS, and an output to a front panel socket, EOS. Potentiometers P7 and P8 are provided for trimming the offset voltages of IC6 and IC7.

Construction

The comments with regard to component quality that have been made in previous chapters apply equally to the construction of the VCA, and will not be repeated. A printed circuit board and component layout for the VCA are

Figures 3a to 3d. Some typical faults of badly-designed or badly-adjusted VCAs are illustrated here. None of the amplitude envelopes in figures 3b to 3d follows the control contour of figure 3a.

In figure 3b there is feedthrough of the signal after the control contour finishes; in figure 3c the signal is still cut off for some time after the control contour starts, and cuts off again before it finishes; in figure 3d the VCA has insufficient headroom and limits causing a 'plateau' on top of the envelope curve.

Figure 4. The principle of the Formant VCA is illustrated here. The OTA produces an output current proportional to the product of the input voltage and the control current I_{ABC} . This causes a voltage drop across the load resistor R_L , and the output is buffered by an op-amp voltage follower. The input attenuator is necessary to avoid overloading the OTA.

Figure 5. Complete circuit of the Formant Dual VCA. This contains two, cascaded, voltage-controlled amplifiers with independent control inputs; exponential control for envelope shaping and linear control for amplitude modulation (tremolo).

given in figure 6, and a front panel layout is given in figure 7.

Testing and adjustment

For optimum performance the VCA must be matched to a particular envelope shaper, and thereafter the VCA and envelope shaper should be used as a pair. This is not necessary in the case of the VCF, which may be used with any envelope shaper.

To test and adjust the VCA, the completed keyboard and interface receiver must be available, together with VCOs, VCF and the envelope shaper to which the VCA is to be matched. The IOS output of the VCO is connected to one of the VCO inputs of the VCF, and the IOS output of the VCF is connected to the IS input of the VCA. The GATE output of the interface receiver is connected to the GATE input of the envelope shaper and output ENV of the envelope shaper is connected to input ENV of the VCA.

For the initial test, the sawtooth output of the VCO is selected and the output level is set to maximum. The VCF is set to the lowpass mode, but the turnover frequency is set to maximum by turning the octaves control fully clockwise. The

Q control is set to minimum, the KOV input is switched off and the output level is set to maximum.

- At the IOS output of the VCF, the sawtooth signal from the VCO should now be available in phase with, and at the same amplitude as, the VCO output (about 2.5 V p-p).

- At the output of IC4 of the VCA, the signal should be available at the same level, but inverted.

- With S1 of the VCA in position 'a' (ENV input switched off) and P7 and P8 in mid-position, the sawtooth signal should be available at the output of IC6 in phase with the VCO output, and the amplitude should be adjustable by P1.

- At the output of IC7 the signal should again be in phase, and both P1 and P3 should vary the amplitude.

- Finally, the signal should be available at outputs IOS and EOS.

This concludes the basic functional check of the VCA, and the adjustment procedure can now be carried out.

Modulation Indicator

Using the same input signal, P6 is adjusted until the modulation indicator D5 just begins to glow. Increase the signal amplitude by switching in the

second and third VCOs, when the LED should glow brighter.

After this test, the second and third VCOs should be switched off again.

Offset adjustment

Turn the output level of the VCF to zero and short the IS input of the VCA to ground. Set S1 of the envelope shaper to 'AD' and the A, D, S and R controls to minimum (shortest attack and decay, and 0% sustain). Turn P5 of the VCA fully anticlockwise, set S1 of the VCA to position 'b' (ENV) and observe the DC output voltage of IC6 on an oscilloscope.

When a key is depressed, a step output voltage will be observed at the output of IC6. This is the offset voltage of the IC, which is amplified as the gain of IC6 increases under the influence of the envelope control voltage; if it is not nulled out then it will break through to the output as 'cracks' or 'plops'. P7 is adjusted until the step voltage is as small as possible on the most sensitive range of the oscilloscope.

The offset nulling procedure must then be repeated for IC7. S1 is switched to the 'off' position, P3 is turned fully anti-clockwise and the external output of the envelope shaper is connected to

5

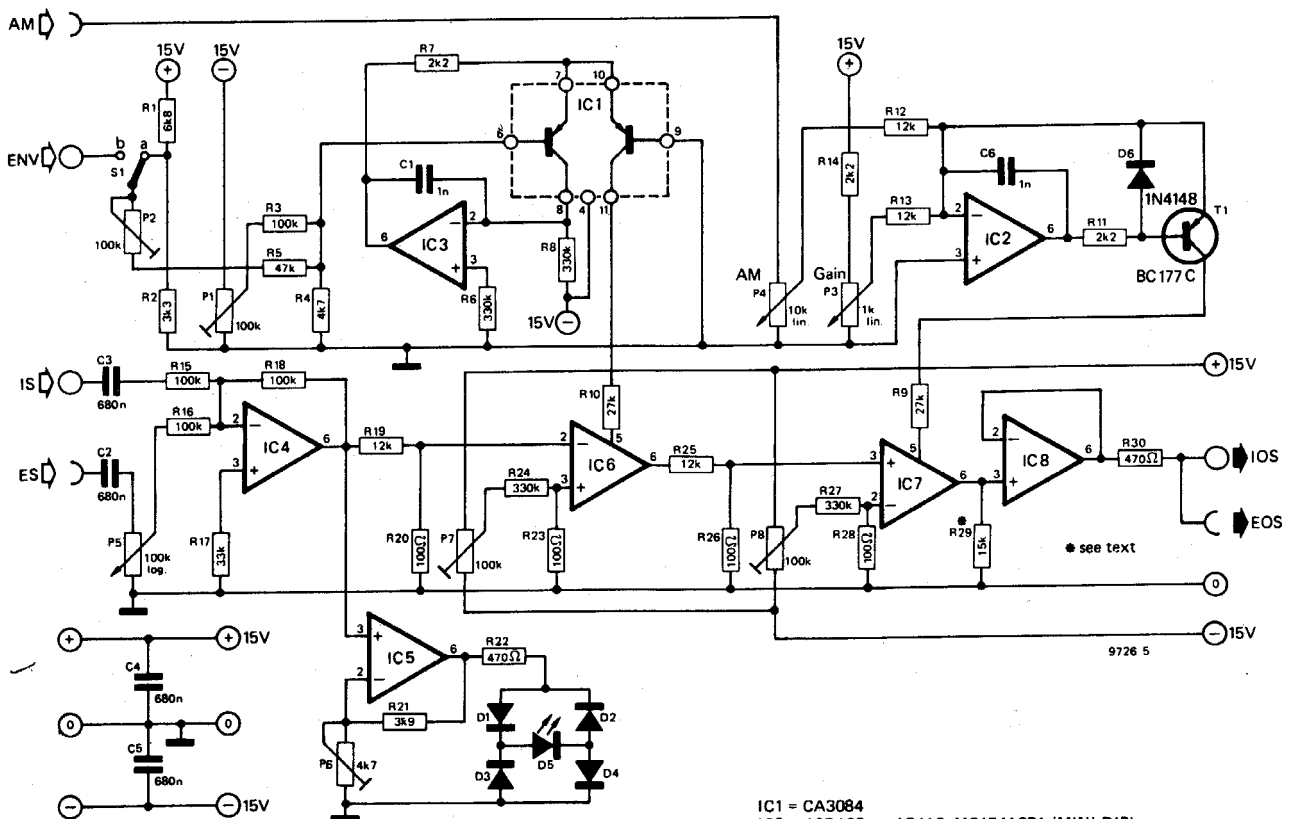

IC1 = CA3084
 IC2 ... IC5, IC8 = μA741C, MC1741CP1 (MINI DIP)
 IC6 ... IC7 = CA3080(A) (MINI DIP)
 D1 ... D4 = OA91, AA119, AA118

6

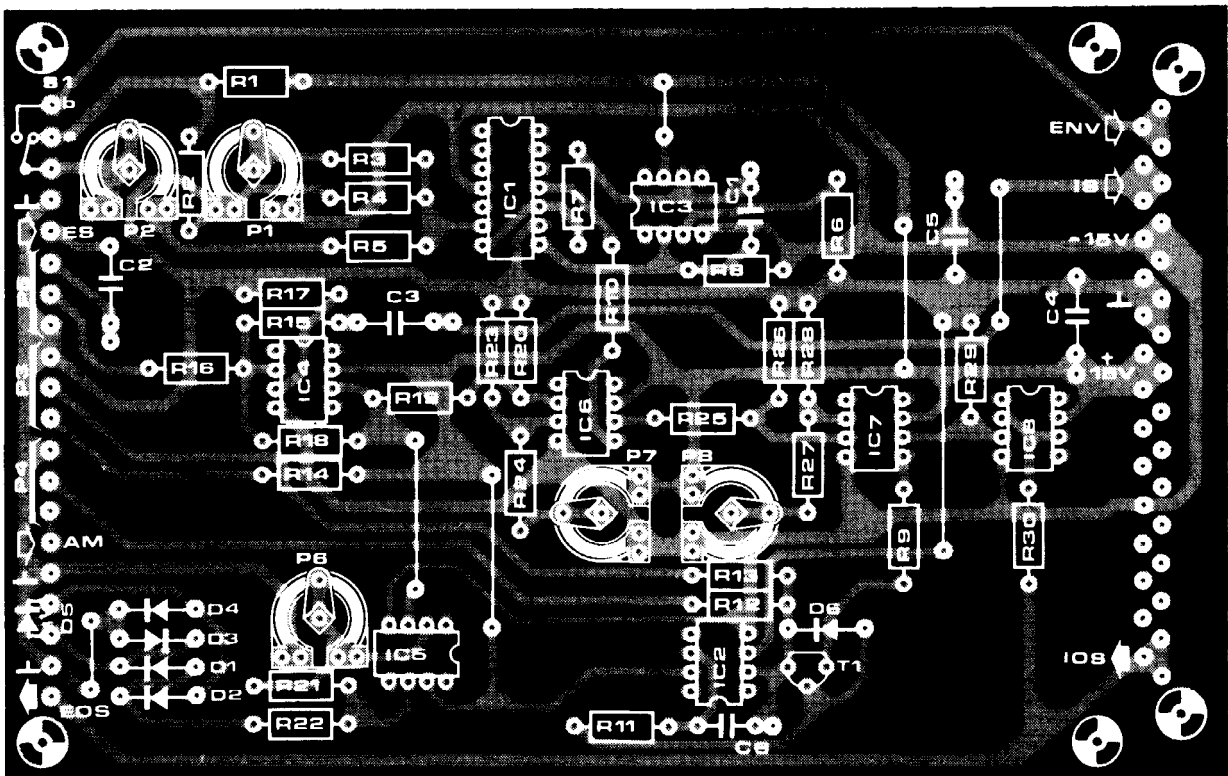
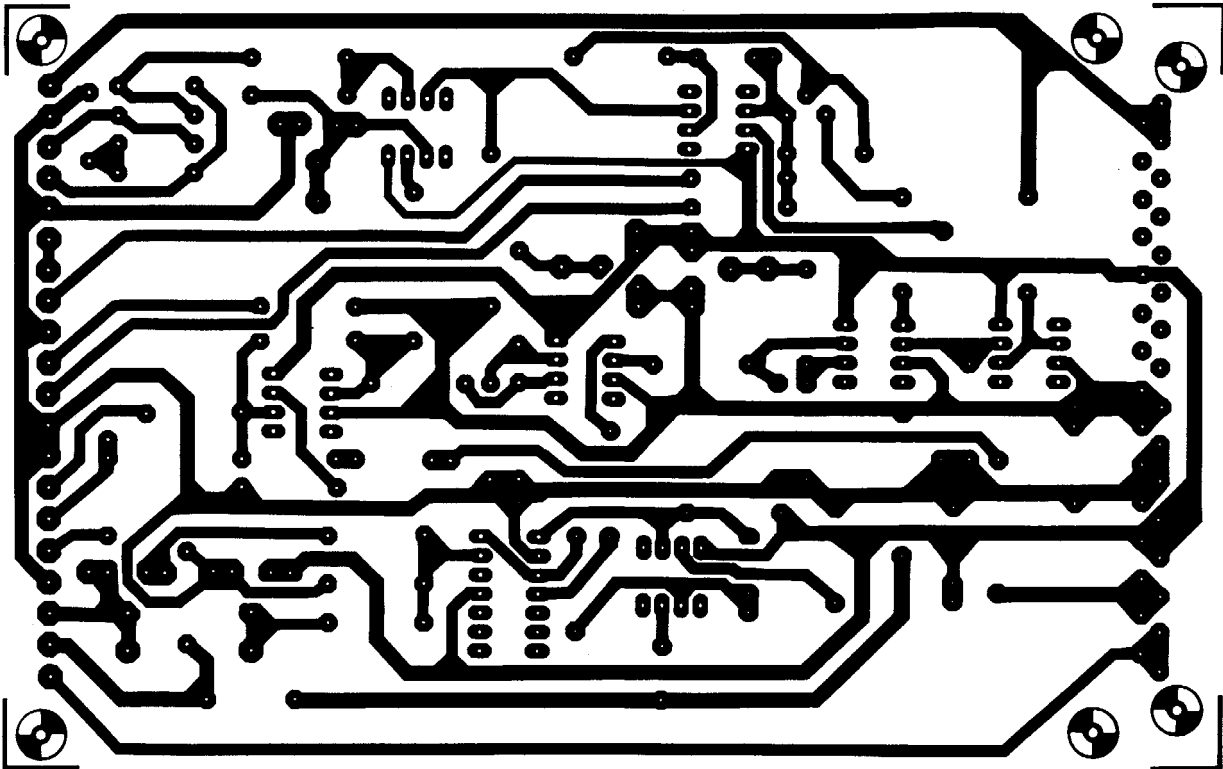

Parts list for figures 5 and 6

Resistors:

R1 = 6k8
 R2 = 3k3
 R3,R15,R16,R18 = 100 k
 R4 = 4k7
 R5 = 47 k
 R6,R8,R24,R27 = 330 k
 R7,R11,R14 = 2k2
 R9,R10 = 27 k
 R12,R13,R19,R25 = 12 k
 R17 = 33 k
 R20,R23,R26,R28 = 100 Ω
 R21 = 3k9
 R22,R30 = 470 Ω
 R29 = 15 k (nominal value,
 see text)

Potentiometers:

P1,P2,P7,P8 = 100 k preset
 P3 = 1 k lin.
 P4 = 10 k lin.
 P5 = 100 k log.
 P6 = 4k7 (5 k) preset

Capacitors:

C1,C6 = 1 n
 C2,C3,C4,C5 = 680 n

Semiconductors:

IC1 = CA 3084 (DIL package)
 IC2,IC3,IC4,IC5, IC8 = μ A 741C,
 MC 1741 CP1 (Mini DIP)
 IC6,IC7 = CA 3080 (A)
 T1 = BC 177B, BC 178C, BC 179C,
 BC 557B, BC 558C, BC 559C
 D1 ... D4 = DUG (OA91,
 AA118, AA119)
 D5 = LED (TIL 209 or similar)
 D6 = 1N4148

Miscellaneous:

31-way Euro connector
 (DIN 41617)
 S1 = SPST miniature toggle
 switch
 3 off, 3.5 mm jack socket
 3 off, 13-15 mm collet knobs with
 pointer

the AM input of the VCA. The IOS output of the VCA is monitored on the oscilloscope and the offset nulling procedure is repeated, this time using P8.

Adjustment of exponential gain control

The exponential converter must be adjusted so that the required gain control range of IC6 is obtained from the +0.5 V to +5 V range of the envelope shaper.

S1 of the envelope shaper is set to the 'AD' position and fairly short attack and decay times are selected. The short circuit across the VCA input is removed, the VCF level control is turned to maximum and a signal is fed in from one of the VCOs. P2 on the VCA board is initially set to its mid-position.

The output of IC6 is now monitored with an oscilloscope and a key is repeatedly depressed, when AD envelope curves should be seen. P1 is then adjusted for minimum feed through when the key is not depressed, less than one or two millivolts will be acceptable. The Y sensitivity of the oscilloscope is now adjusted so that the entire envelope curve can be seen when a key is depressed. P2 should then be adjusted until a good attack/decay curve without limiting (seen as a flat top or plateau as

shown in figure 3d) is just obtained. Since P1 and P2 interact to some extent, it may be necessary to repeat the adjustment procedure several times to obtain the best results.

Adjustment of overall gain

The overall gain of the VCA should be 0 dB (unity) at maximum modulation of IC6 and IC7. To achieve this it may be necessary to alter the value of R29, which is nominally 15 k. Set the gain control P3 to maximum, and the envelope shaper to the 'ADSR' mode with 100% sustain. A key is now depressed and held down, and the output level of the VCA (at IOS or EOS) is compared with the input level at IS. These levels should be the same; if the output level is too low, then R29 must be increased in value, and if the output level is too high then R29 must be reduced. A 3 dB difference ($\times 0.707$ or $\times 1.414$) between the input and output levels is acceptable.

This completes the adjustment of the VCA.

Use of the VCA

The input signal level to the internal input of the VCA is controlled by the output potentiometer of the VCF. In

7

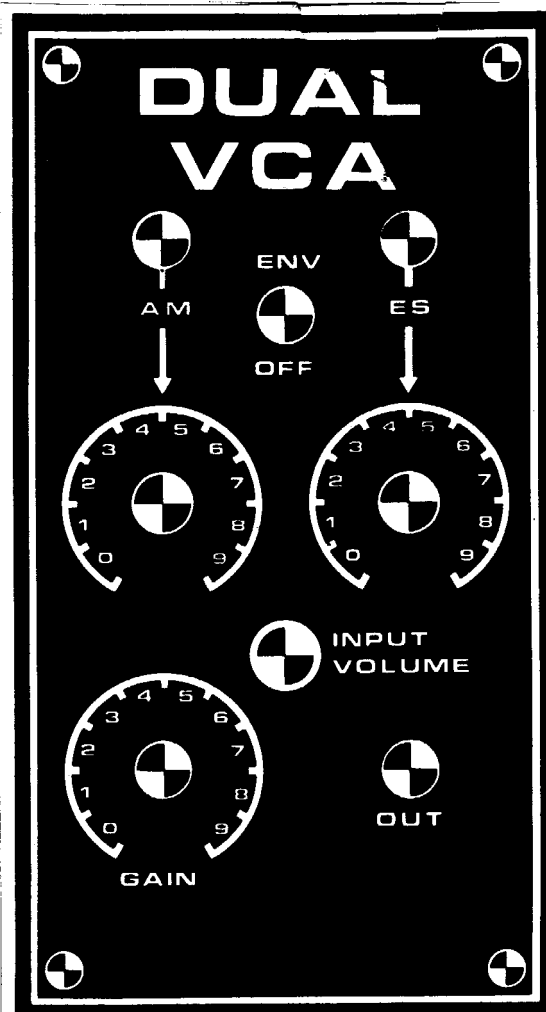

Figure 6 Printed circuit board and component layout for the VCA (EPS 9726-1).

Figure 7 Front panel layout of the VCA. S1 is located between the AM and ES input sockets. Immediately below these sockets are the respective input level controls: P4 sets the AM modulation depth and P5 is the external input level control. Below these again are the modulation indicator (D5), the manual gain control (P3) and the output socket (EOS).

normal use this control should be adjusted so that the LED just begins to glow, which occurs at a nominal level of 2.5 V p-p with one VCO input signal, less if more than one VCO is connected. If the LED glows brightly, then the VCA is being overmodulated and distortion may occur. This is not to say that this should never be allowed to happen, since the deliberate introduction of distortion can be used to produce 'fuzz' effects. If the LED does not glow, then this indicates under-modulation and the possibility of a poor signal-to-noise ratio.

Tremolo

To produce tremolo effects a low-frequency oscillator signal (LFO) can be fed into the AM input socket. The Formant LFOs, described later in the series, have an output voltage swing of ± 2.5 V, and if the GAIN potentiometer P3 is set in its mid-position this will give a modulation depth of 100%. Reducing the LFO input signal by means of the AM potentiometer P4 allows the modulation depth to be varied down to 0%.

Expression Pedal

An expression pedal may also be connected to the AM input. This can be a pedal fitted with a logarithmic potentiometer and battery, whose output can be varied from zero to about +5 V with the pedal fully depressed.

Tuning

The ENV/OFF switch S1 is particularly useful when tuning the synthesiser, since it allows signals to pass continuously through the VCA, unaffected by the envelope shaper when in the OFF position.

Outputs

The external output of the VCA has an impedance of about 500 Ω , and this output may be fed to other equipment such as tape decks and external amplifiers, or to high impedance headphones for monitoring.

The internal output signal (IOS) is taken to the Formant amplifier module, which will be described later. This is fitted with tone and volume controls and a small power amplifier for monitoring purposes. It will drive low impedance headphones and loudspeakers, and can also be used to drive spring line reverb units or other external equipment.

chapter 11

LFOs and noise module

The low frequency oscillators and noise generator are invaluable components in a synthesiser system. The LFOs allow amplitude and frequency modulation of the VCO outputs to provide tremolo, vibrato and other effects. The noise sources can be used for random modulation of the VCO signals, and in addition can be used as signal sources themselves.

Mention has already been made of the fact that conventional instruments exhibit more 'life' and variation in tonal character than electronic instruments due to the way in which they are played. For example, string instruments and woodwind instruments can exhibit marked tremolo and vibrato due to variations in the ~~breath~~ or blowing. The keyboard of a synthesiser provides a relatively inflexible and expressionless means of playing that does not allow these nuances to be introduced into the sound, and in order to make the sound more 'lively' amplitude and frequency modulation must be introduced using the LFOs and noise source.

The noise source also provides the basic material to produce a whole spectrum of sounds that do not have a defined pitch. White noise can be used to produce sounds such as wind, rain and surf. 'Coloured' noise, which is white noise with the low frequency components boosted, is used for sounds having a strong bass content, such as the rumbling of thunder.

In addition to modulating the VCO signals, noise can also be added to these signals to simulate wind noise in organ pipes and woodwind instruments.

The LFO module

The Formant LFOs are basically low-frequency function generators that produce three different waveforms. Each LFO module contains three LFOs, two of which are identical and produce square, triangle and sawtooth

waveforms. The third LFO produces a triangular waveform and two sawtooth waveforms in antiphase with each other, i.e. one with a positive-going ramp and the other with a negative-going ramp.

The circuit of LFO1 is shown in figure 1a; LFO2 is identical. The basic oscillator circuit consists of two op-amps IC1 and A3 connected respectively as an integrator and a Schmitt trigger. When the output of A3 is positive a potential of about +2.5 V (depending on the position of the wiper of P3) is applied to R9. The full positive output voltage of A3 is applied to P1, so a current (dependent on the wiper position of P1) flows into the integrator through R1. The output of IC1 ramps negative until it reaches about -2.5 V, when the voltage on the non-inverting input of A3 will fall below the voltage on the inverting input (zero volts) and the output of A3 will swing negative. The voltage applied to R9 is now -2.5 V, and the full negative output voltage of A3 is applied to P1. Current will flow out of the integrator through R1, and the integrator output will ramp positive until it reaches about +2.5 V, when the voltage on the non-inverting input of A3 will rise above zero and the output of A3 will swing positive. The whole cycle then repeats.

The output from IC1 is thus a triangular waveform with a peak-to-peak voltage of about 5 V, while at the wiper of P3 a squarewave of the same amplitude and frequency is available. P3 presets the trigger threshold of A3 and hence the signal amplitude. P1 is used to adjust the frequency of the LFO by varying the voltage applied to the integrator input, which alters the integrator input current and hence the rate at which the integrator ramps positive or negative.

The triangular wave output is taken direct from IC1 via R13, whilst the squarewave output is buffered by voltage follower A4. The sawtooth waveform is derived from the triangle by A2. When the output of A3 is positive and the triangle output is on its negative-going slope, T1 is turned on, grounding the non-inverting input of A2. A2 thus functions as a unity-gain inverting amplifier, producing a positive-going ramp. When the output of A3 is negative and the output of IC1 is positive going, T1 is turned off and A2 functions as a unity-gain non-inverting amplifier (voltage follower), again producing a positive-going ramp. The positive- and negative-going ramps of the triangular waveform are thus converted into a series of positive-going ramps. Since every half-cycle of the triangle is converted into a full cycle of the sawtooth, the frequency of the sawtooth is twice that of the triangle and square waveforms, as illustrated in figure 2.

To indicate that the LFO is functioning a LED indicator, constructed around A1, is connected to the triangle output.

Figure 1a. Circuit of LFO 1, which is identical to LFO 2 and produces triangle, sawtooth and square waveforms.

Figure 1b. LFO 3 also produces three waveforms, but instead of a squarewave output a negative-going sawtooth is provided.

The third LFO circuit, shown in figure 1b, is similar to the first circuit, with two exceptions. Firstly, no squarewave output is provided; secondly, a sawtooth with negative-going slope is provided by A8, which inverts the positive-going sawtooth from A6.

Construction of the LFO module

Figure 3 shows the printed circuit board and component layout of the LFO module, which of course contains three LFOs. The components for LFO2 are identical to those for LFO1, being distinguished on the board and in the components list by an apostrophe ('). The board layout is fairly cramped, and care should be taken when soldering components to avoid solder bridges. A front panel layout is given in figure 4.

Adjustment of the LFOs

- Each LFO requires four adjustments:
- P3, P3' and P7 set the signal amplitude.
 - P2, P2' and P5 null the offset of the integrators.
 - R16, R16' and R17 must be selected to set the lowest frequency of the LFO.
 - P4, P4' and P6 adjust the LED indicators.

The adjustment procedure, which is identical for all three LFOs, will be described for LFO1.

Amplitude adjustment

1. Monitor the triangle output on an oscilloscope; set P2 to its mid-position and P1 for maximum frequency.
2. Adjust P3 to give a peak-to-peak output of 5 V.
3. Check the amplitude and waveform of the other outputs.

Offset adjustment

1. Disconnect R1 from the wiper of P1 and ground it.
2. Monitor the output voltage of IC1 with a multimeter. It will probably exhibit a tendency to drift positive or negative, and the voltage will settle at +15 V or -15 V. Reset the

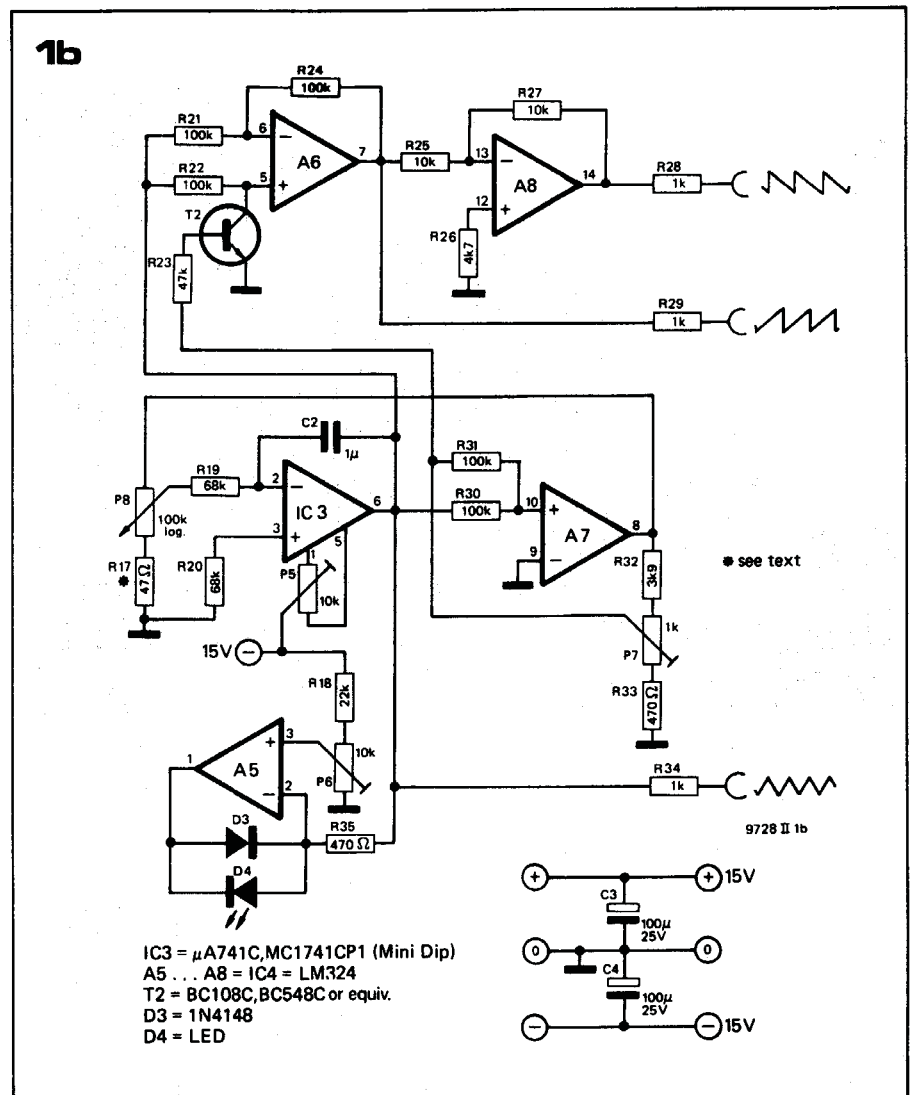
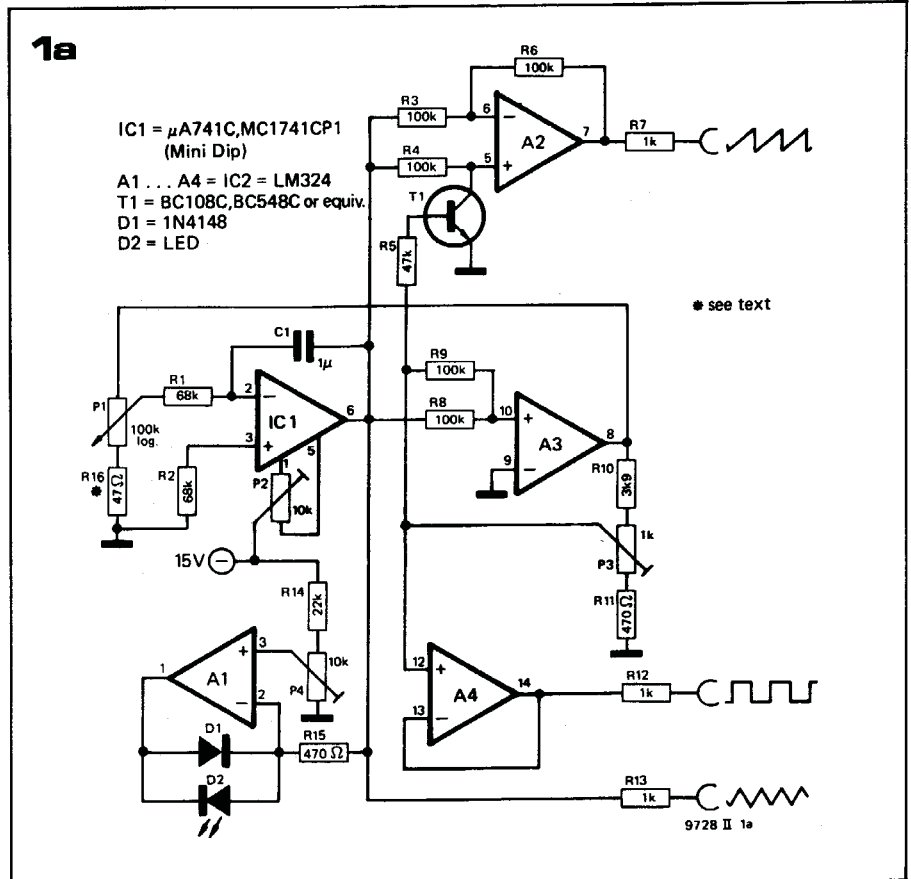

2

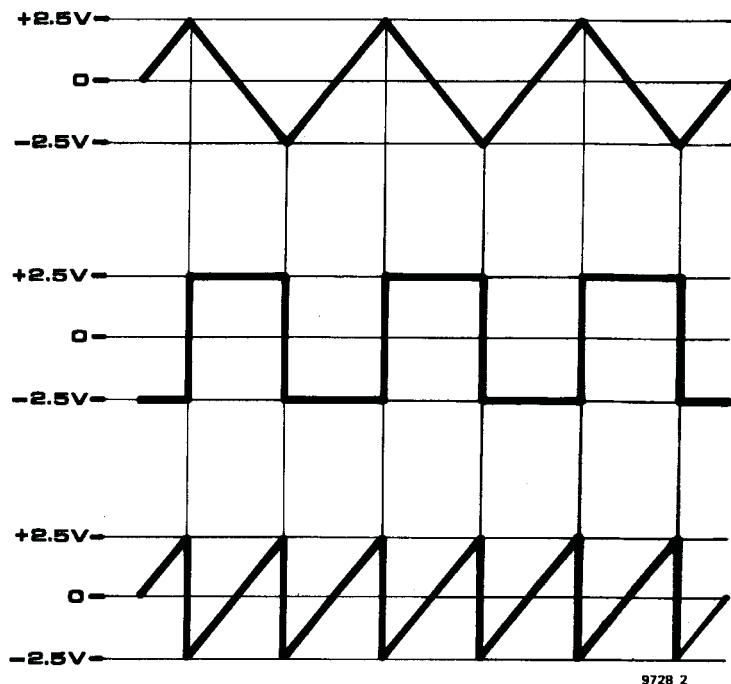

9728 2

Figure 2. Showing the phase relationship of the triangle, square and sawtooth waveforms. Since the sawtooth is derived by inverting alternate half-cycles of the triangle waveform, its frequency is twice that of the other waveforms.

Figure 3. Printed circuit board and component layout for the LFO module (EPS 9727-1).

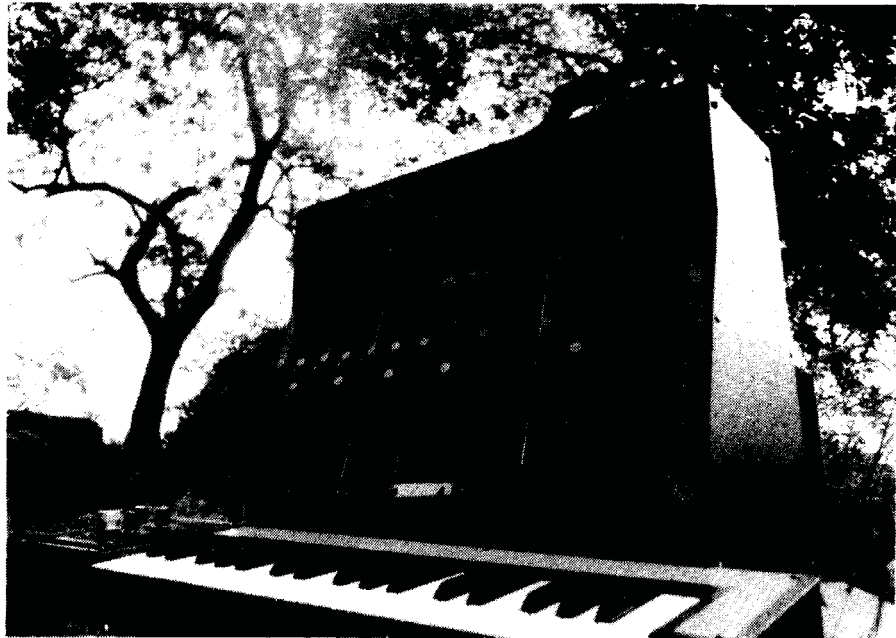

output voltage to zero by discharging C1 through a 1 k resistor. Adjust P2 until the voltage remains stable at zero volts for a period of several seconds (without the discharge resistor in circuit). Repeat this adjustment, progressively switching the multimeter to more sensitive ranges until the drift is only a few hundred millivolts in several seconds.

Careful adjustment of the offset is vital, as it determines the minimum frequency at which the LFO will operate

reliably and the symmetry of the waveforms at low frequencies.

Selection of R16

The value of R16 determines the minimum integrator input voltage that can be set by P1, and hence the minimum frequency of the LFO. The value of R16 must not be chosen too high or the minimum LFO frequency will be too great. On the other hand it should not be chosen too low, or the integrator input current at the minimum

setting of P1 will be comparable with the input currents of IC1. This will result in unreliable operation of the oscillator at low frequencies.

R16 should be chosen so that the minimum frequency of the LFO is about one cycle every three minutes, but the value of R16 should not be less than $10\ \Omega$. If it is not possible to obtain this low frequency then the input currents of IC1 may be too high, or C1 may be leaky.

The maximum LFO frequency is about 20 Hz.

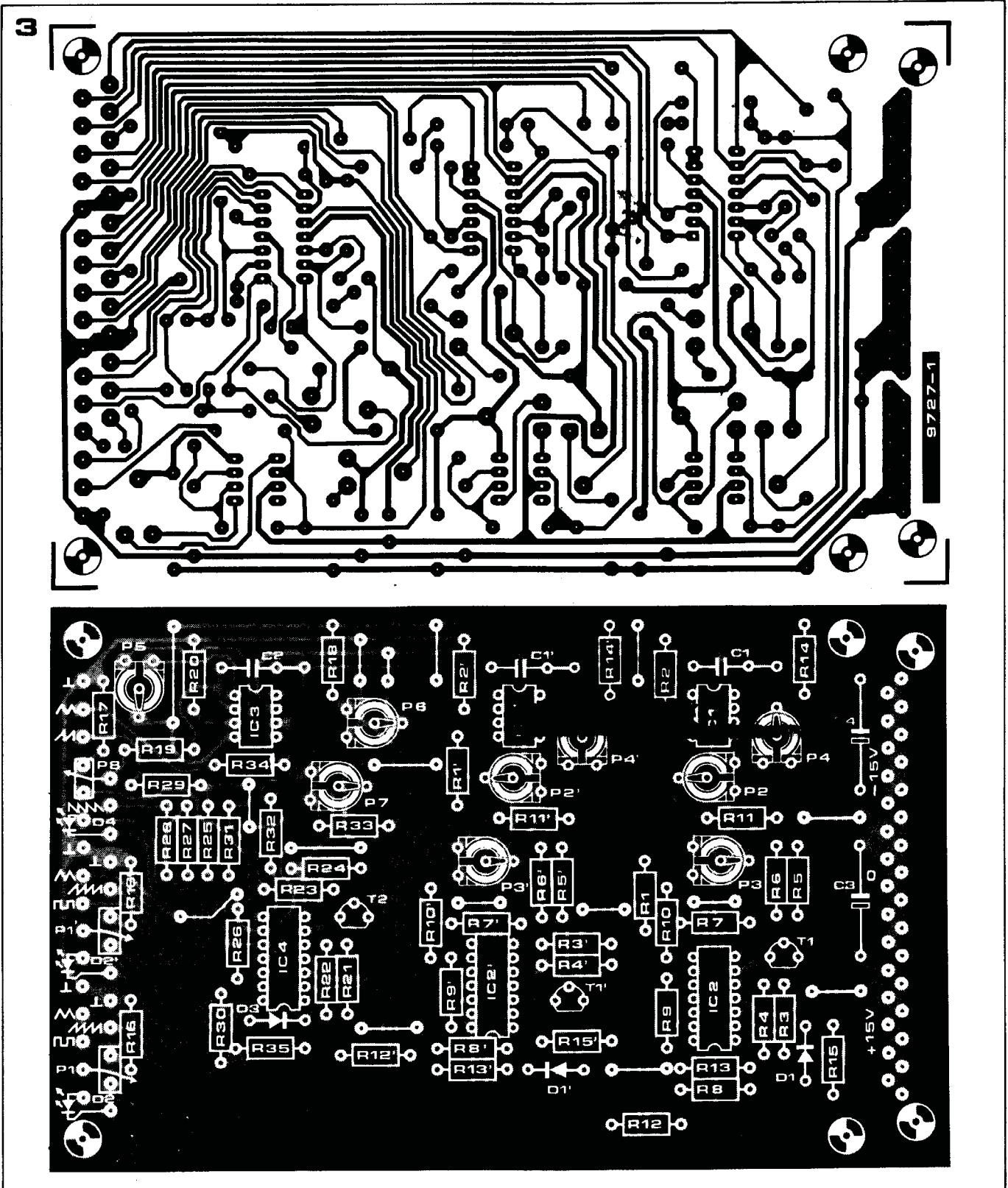

Parts list for LFO module

Resistors:

R1, R1', R2, R2', R19, R20 = 68 k
 R3, R3', R4, R4', R6, R6', R8, R8',
 R9, R9', R21, R22, R24, R30,
 R31 = 100 k
 R5, R5', R23 = 47 k
 R7, R7', R12, R12', R13, R13', R28,
 R29, R34 = 1 k
 R10, R10', R32 = 3k9

R11, R11', R15, R15', R33,
 R35 = 470 Ω
 R14, R14', R18 = 22 k
 R16, R16', R17 = 47 Ω (see text)
 R26 = 4k7

Potentiometers:

P1, P1', P8 = 100 k log
 P2, P2', P4, P4', P5, P6 = 10 k preset
 P3, P3', P7 = 1 k preset

Semiconductors:

IC1, IC1', IC3 = μA 741C,
 MC 1741CP1 (Mini DIP)
 IC2, IC2', IC4 = LM 324 (DIP)
 T1, T1', T2 = BC 108C, BC 548C or
 equivalent
 D1, D1', D3 = 1N4148, 1N914
 D2, D2', D4 = LED (e.g. TIL209)

Capacitors:

C1, C1', C2 = 1 μ (polyester or
 polycarbonate)
 C3, C4 = 100 μ/25 V

Miscellaneous:

31-way connector (DIN 41617)
 9 x 3.5 mm jack
 3 x 13 . . . 15 mm knobs

4

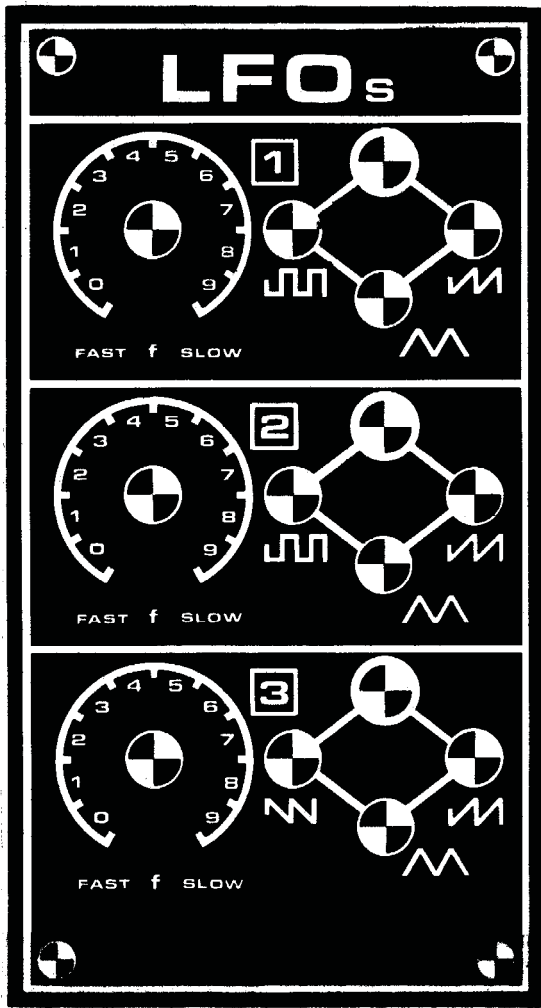
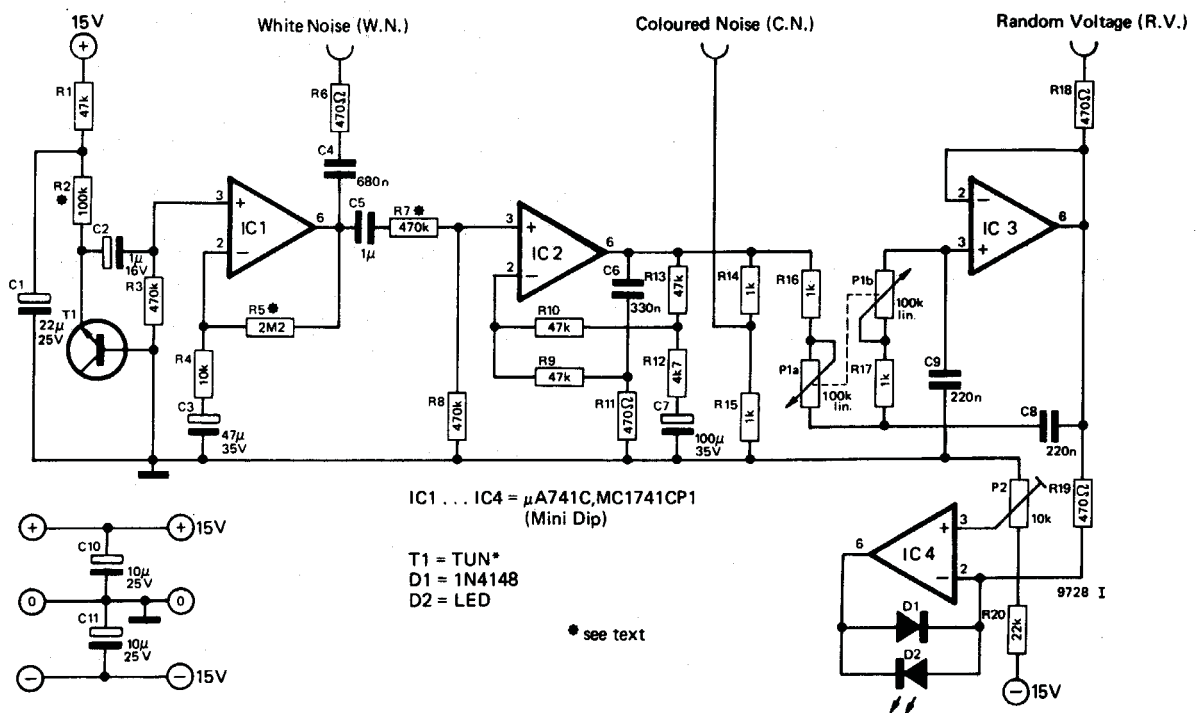

Figure 4. Front panel layout of the LFO module.

Figure 5. Circuit of the noise module.

Figure 6. Printed circuit board and component layout for the noise module (EPS 9728-1).

5



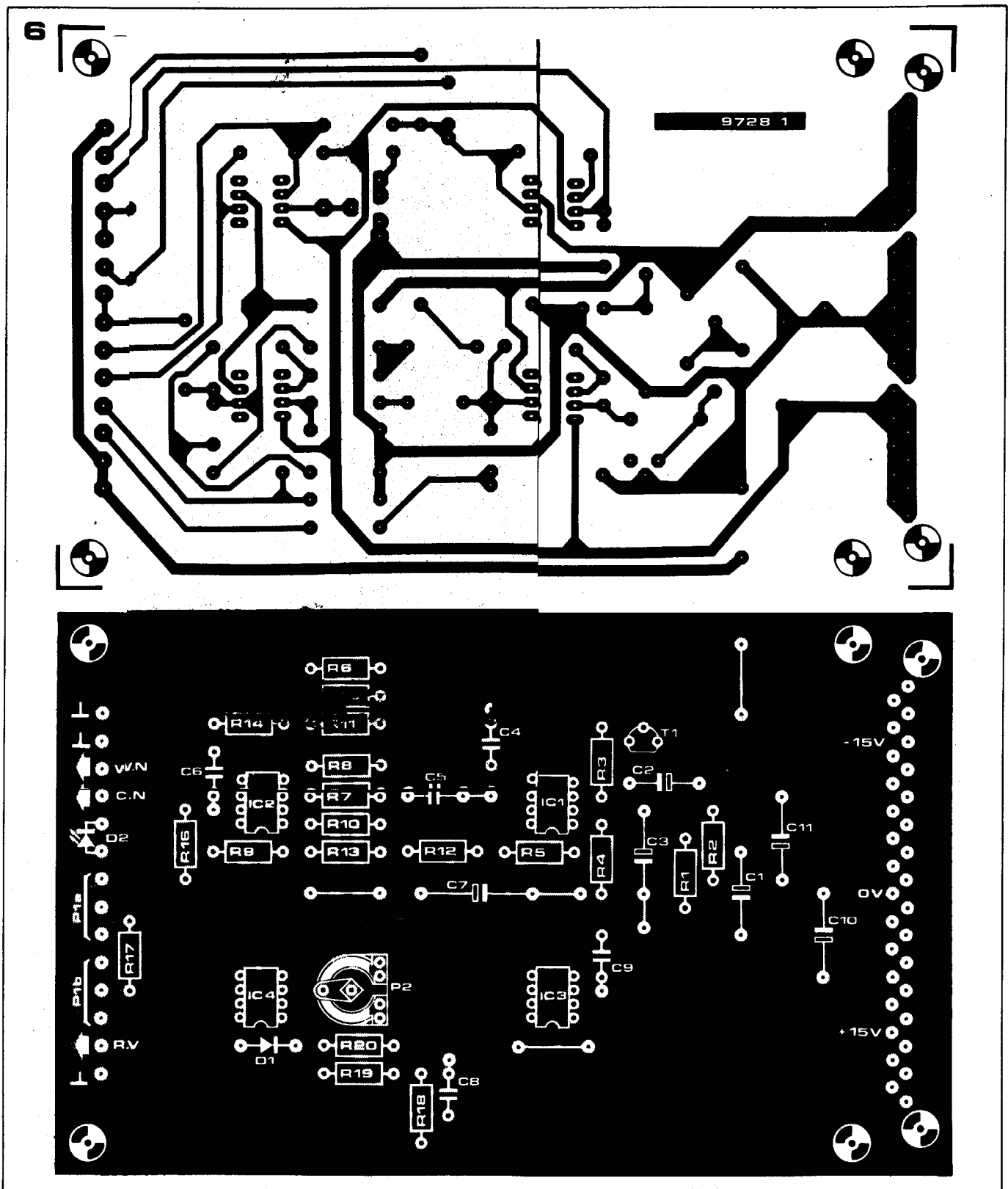

Parts list for noise module

Resistors:

R1,R9,R10,R13 = 47 k
 R2 = 100 k (see text)
 R3,R7,R8 = 470 k
 R4 = 10 k
 R5 = 2M2 (see text)
 R6,R11,R18,R19 = 470 Ω
 R12 = 4k7
 R14,R15,R16,R17 = 1 k
 R20 = 22 k

Capacitors:

C1 = 22 μ/25 V
 C2 = 1 μ/16 V
 C3 = 47 μ/35 V
 C4 = 680 n
 C5 = 1 μ (polyester or polycarbonate)
 C6 = 330 n
 C7 = 100 μ/35 V
 C8,C9 = 220 n
 C10,C11 = 10 μ/25 V

Semiconductors:

IC1,IC2,IC3,IC4, = μA 741C,
 MC 1741CP1 (Mini DIP)
 T1 = TUN (selected)
 D1 = 1N4148, 1N914
 D2 = LED (e.g. TIL 209)

Potentiometers:

P1 = 100 k lin. ganged
 potentiometer
 P2 = 100 k preset

Miscellaneous:

1 x transistor socket
 1 x 31-way connector (DIN
 41617)
 3 x 3.5 mm jack sockets
 1 x 13 ... 15 mm knob

Adjustment of the LED indicator

P4 should be adjusted so that the brightness of the LED follows the amplitude of the triangle output, i.e. the LED should be at minimum brightness when the triangle voltage is at its most negative, and at maximum brightness when the triangle is at its most positive. P4 should be adjusted so that the LED brightness does not reach maximum before the peak of the triangle, but on the other hand it should not extinguish completely before the trough of the triangle.

The noise module

The complete circuit of the noise module is shown in figure 5. The noise is produced by the base-emitter junction of an NPN transistor T1, which is reverse-biased. The noise is amplified to a level of about 2.5 V peak-to-peak. This white noise output is fed out via C4 and R6.

The white noise is also fed into a filter constructed around IC2, which has two frequency dependent elements in the feedback path. These two elements interact as follows. On its own, the feedback network comprising R10, R12, R13 and C7 would produce a 6 dB/octave rise in the gain of IC2, from 0 dB at zero Hz via 3 dB at 9 Hz to approximately 20 dB at 90 Hz. The feedback network R9, R11, C6, on its own would produce a 6 dB/octave fall in gain from 0 Hz to 1 kHz, above which the gain would remain constant at 0 dB.

The combined effect of these feedback networks is that below 90 Hz the 6 dB/octave rise and 6 dB/octave fall cancel out, giving a gain of 20 dB. Above 90 Hz the gain falls at 6 dB/octave to 0 dB at 1 kHz, above which it remains constant. The result is that the bass end of the noise spectrum is boosted, and 'coloured' noise is available at the output of IC2. The coloured noise output is taken from the junction of R14 and R15.

The coloured noise output is also fed to a second filter built around IC3. This is a 12 dB/octave lowpass filter with variable turnover frequency, which passes only the very low frequency components to produce an extremely low frequency 'random voltage'. The fluctuation rate of this random voltage is adjusted by means of P1, which varies the turnover frequency of the filter. Fluctuations of the random voltage are displayed on a LED indicator, which is identical to those used in the LFOs.

Construction and adjustment of the noise module

A printed circuit board and component layout for the noise module are given in figure 6, and the front panel layout is given in figure 7.

As not all transistors are suitable noise generators, a socket should be fitted in

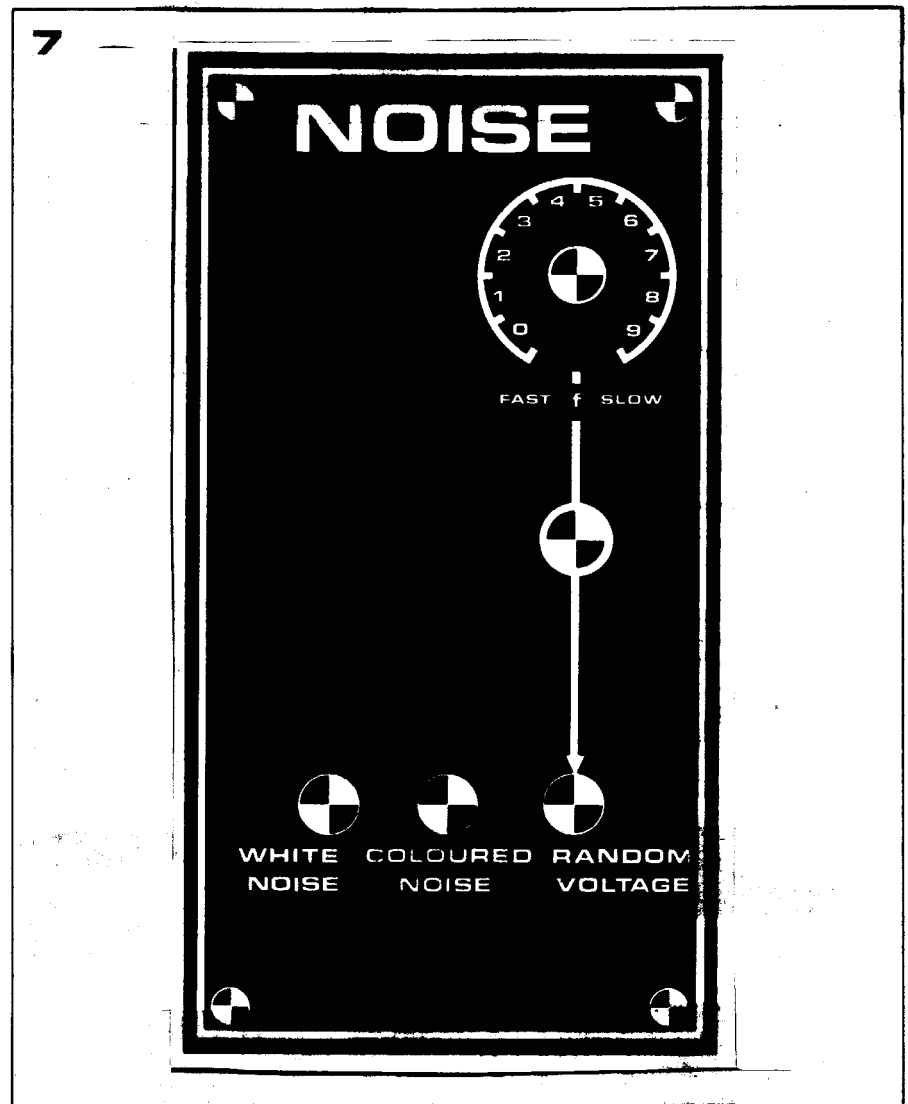

Figure 7. Front panel layout of the noise module.

the T1 position on the board so that different transistors may be tried. Measuring with a multimeter on a suitable AC voltage range at the white noise output, a voltage of 0.5 V to 0.8 V should be present. Alternatively, if an oscilloscope is used to monitor the output, a noise signal of about 2 V to 2.8 V peak-to-peak should be obtained. It may be necessary to try several transistors before a suitable one is found. Varying the value of R2 between 33 k and 150 k may also help.

If the transistor produces too high a noise level this can be reduced by making R5 smaller, thus reducing the gain of IC1.

The amplitude of the coloured noise output should also lie in the same range as the amplitude of the white noise output. If it is too small then R7 should be reduced and if it is too large R7 should be increased.

The random voltage output should vary between about +2.5 V and -2.5 V with P1 in the 'fast' position.

The final adjustment to the noise module is to set P2 so that the LED brightness indicates the amplitude of the random voltage output in a linear manner. This adjustment is carried out in exactly the same way as the adjustment of the LFO indicators.

chapter 12

COM

With a description of the COM (Control and Output Module), and an overall wiring diagram for the 'basic' Formant system, this chapter brings Part 1 of the book, which has dealt with the design and constructional aspects of the various Formant modules, to a close.

The COM contains a tone control amplifier with bass, middle, treble and volume controls, and an output buffer capable of driving high impedance (> 600 Ω) headphones for monitoring or practice purposes. The COM front panel also contains the indicator LEDs for the three power supply voltages and the gate signal. These indicators should not be regarded merely as a gimmick but as an important aid to monitoring the state of the Formant system. A fault in any of the supply voltages is immediately indicated by one of the LEDs, as is the absence of a gate pulse.

COM circuit

The complete circuit of the COM is given in figure 1a.

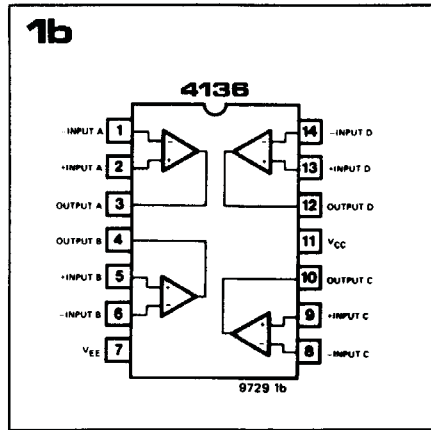
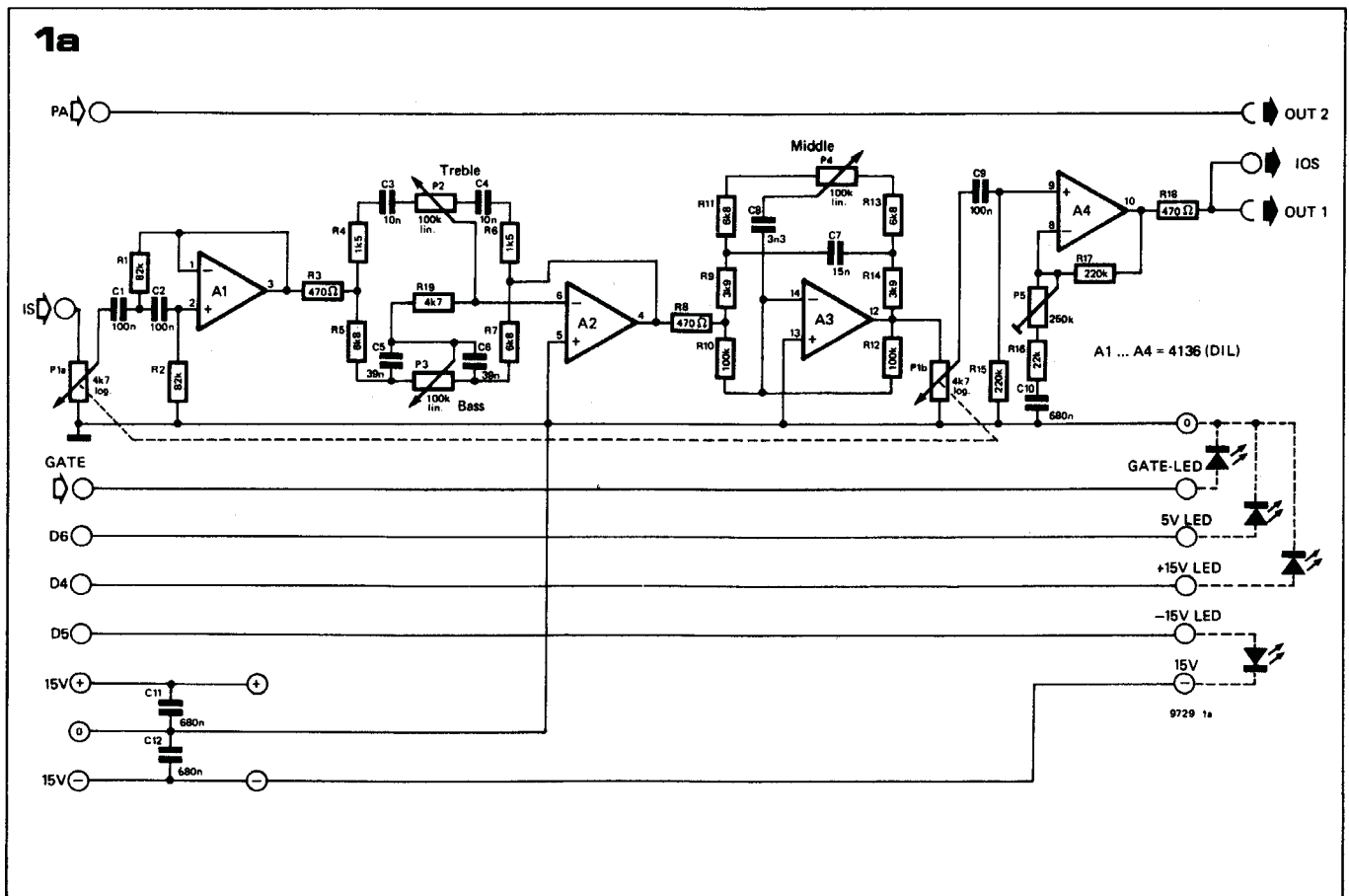

Figure 1a. Circuit diagram of the COM, which consists of a tone control/headphone amplifier and indicator LEDs for gate pulse and the three power supply voltages.

Figure 1b. Pinout of the 4136 IC.

The input signal is fed to a volume control P1a and thence to an 'anti-plop' filter built around A1. This is a 12 dB/octave highpass filter with a break frequency of around 20 Hz. It suppresses low-frequency transients and rolls off the bass response of the system to reduce 'listener fatigue' which can be caused by the low bass notes of electronic music, especially with full bass boost. By rolling off the bass response the filter also helps protect the bass drivers of the loudspeakers against excessive, very low-frequency signals. Indeed, if the synthesiser is to be used with small 'bookshelf' speakers it may be advisable to raise the turnover point of the filter to 40 Hz by changing the value of R1 and R2 to 39 k.

The treble and bass controls, built around A2, are a conventional Baxandall network. To avoid the middle control interacting with the bass and treble controls it is constructed separately around A3. The output of A3 then feeds into a second volume control P1b. The use of a ganged volume control on a single signal channel may seem a little unusual, but it does have several advantages. A volume control at the input to the COM prevents any possibility of overloading A1, whatever the signal level. On the other hand, the provision of a volume control later in the circuit allows a better signal-to-noise ratio to be maintained at low settings of the volume control, since noise (principally from A1) is attenuated along with the signal as the control is turned down. The fact that this control produces a 'double



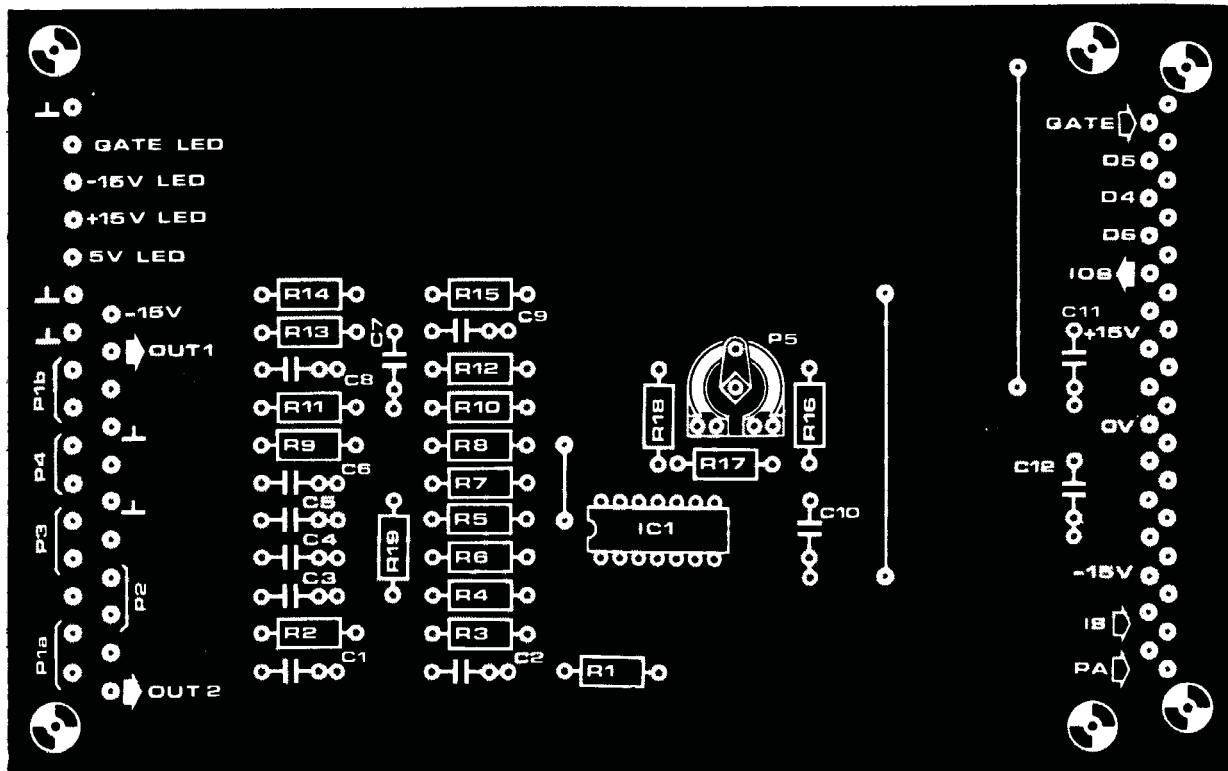
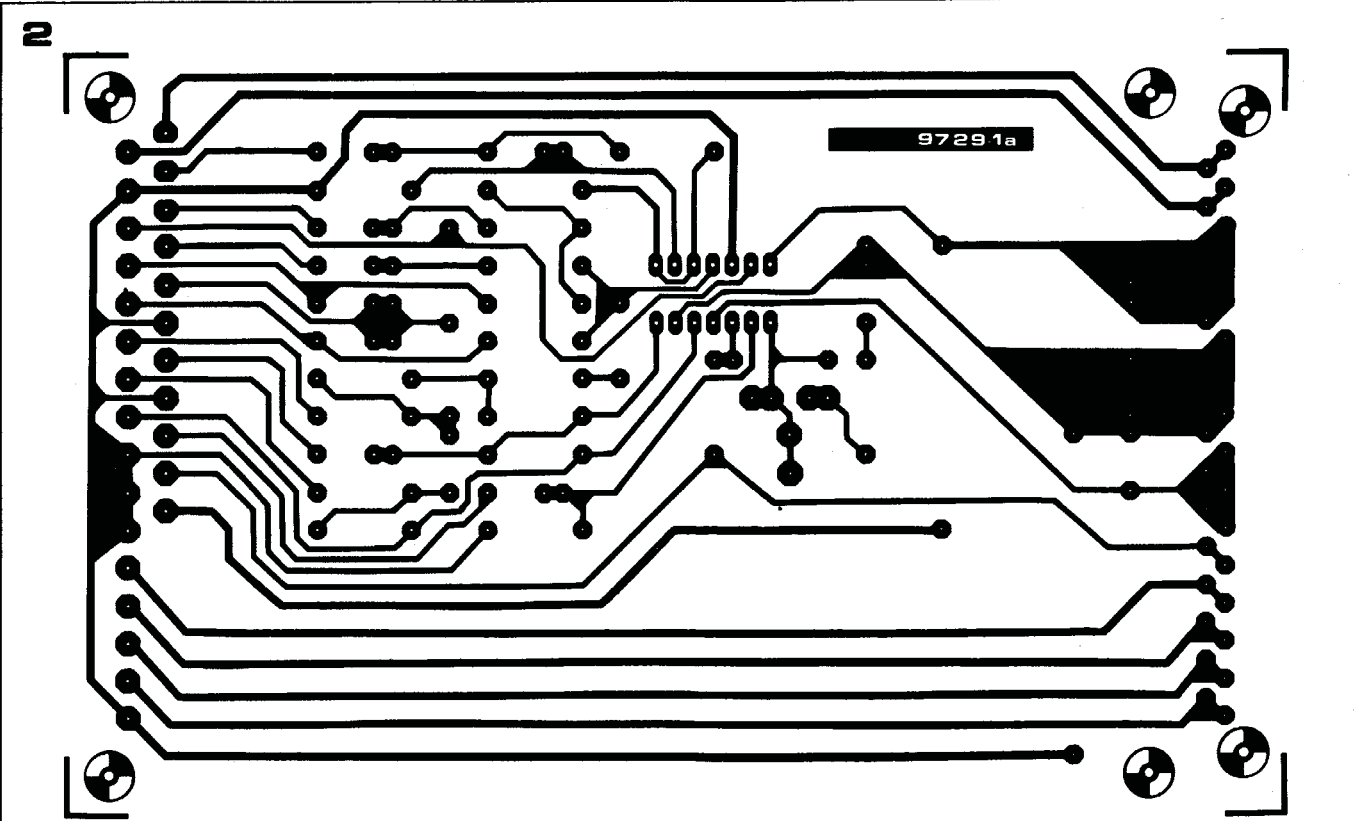

Parts list for figures 1 and 2.

Resistors:

- R1, R2 = 82 k
- R3, R8, R18 = 470 Ω
- R4, R6 = 1k5
- R5, R7, R11, R13 = 6k8
- R9, R14 = 3k9
- R10, R12 = 100 k
- R15, R17 = 220 k
- R16 = 22 k
- R19 = 4k7

Potentiometers:

- P1a, P1b = 4k7 log ganged pot.
- P2, P3, P4 = 100 k lin.
- P5 = 220... 270 k preset.

Capacitors:

- C1, C2, C9 = 100 n
- C3, C4 = 10 n
- C5, C6 = 39 n
- C7 = 15 n
- C8 = 3n3
- C10, C11, C12 = 680 n

Semiconductors:

- IC1 = 4136 (DIL package) EXAR, Fairchild, Raytheon or Texas.

Miscellaneous:

- 31-way connector to DIN 41617
- 3.5 mm jack socket
- 6.3 mm jack socket
- 4 collet knobs, 13...15 mm diameter, with pointer.

Figure 2. Printed circuit board and component layout of the COM (EPS 9729-1).

Figure 3. Front panel layout for the COM (EPS 9729-2).

Figure 4. Wiring diagram for the front panel mounted components.

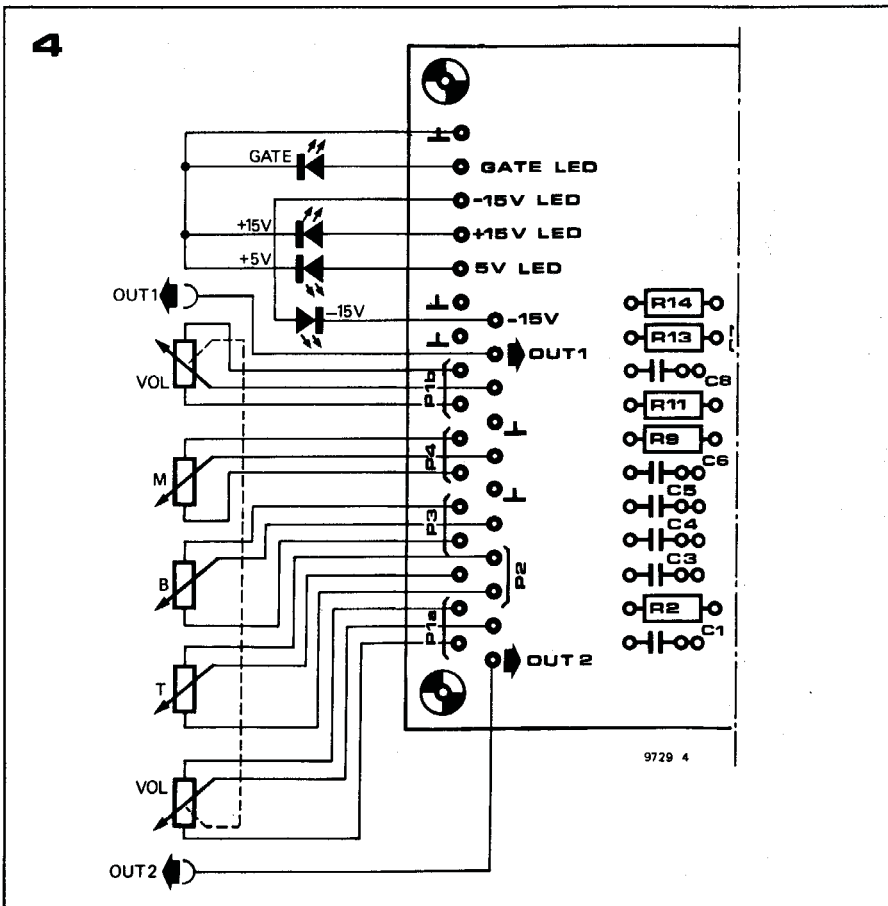

logarithmic' characteristic does not cause any inconvenience in operation. No power amplifier is built into the COM as the heat generated in the output stage could cause temperature drift problems in other circuits in the system. However, the COM is provided with an internal output to a separate power amplifier, IOS. The output of the amplifier may then be brought back through the COM via the PA input connection on the COM board edge connector to a socket on the COM front panel (OUT 2). The COM output is itself also brought out to a socket on the front panel (OUT 1) into which high impedance headphones may be plugged. Note that a 6.3 mm jack socket is used for OUT 2. The four indicator LEDs also receive their power via the COM edge connector from the appropriate circuits, and are also mounted on the COM front panel.

Construction and testing of the COM

A printed circuit board and component layout for the COM are given in figure 2, a front panel design is given in figure 3 and wiring to front panel mounted components is shown in figure 4. Screened leads should be used for the connections to bass, middle and treble potentiometers B, M, and T.

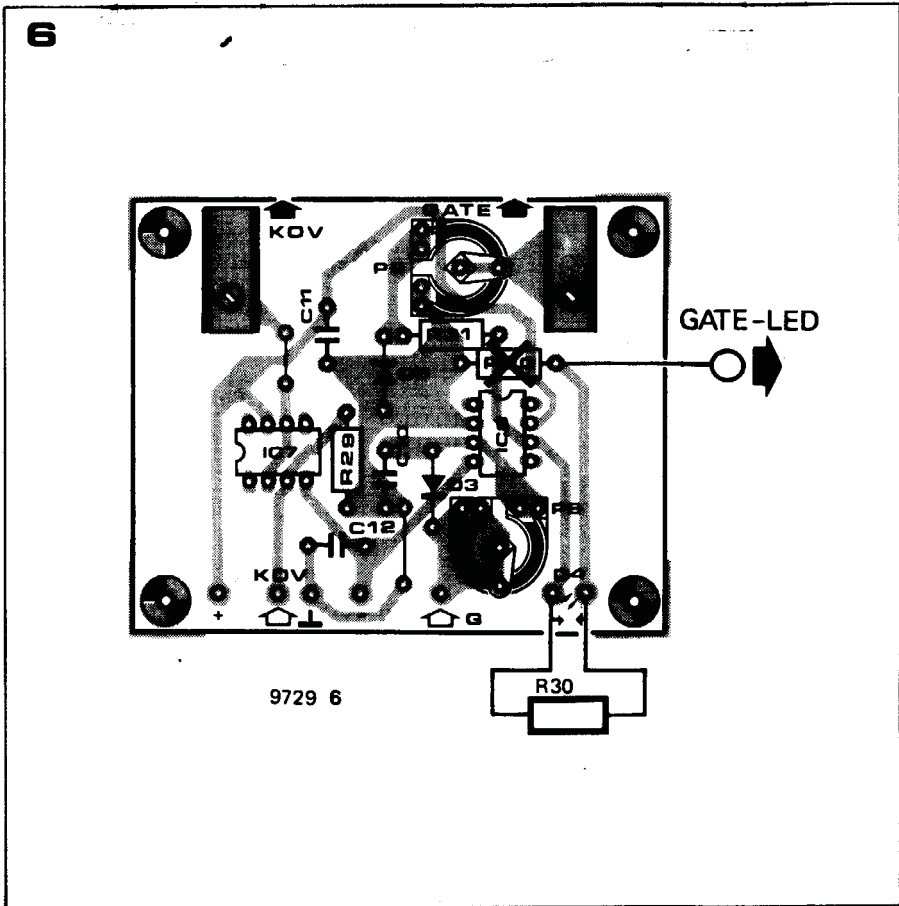
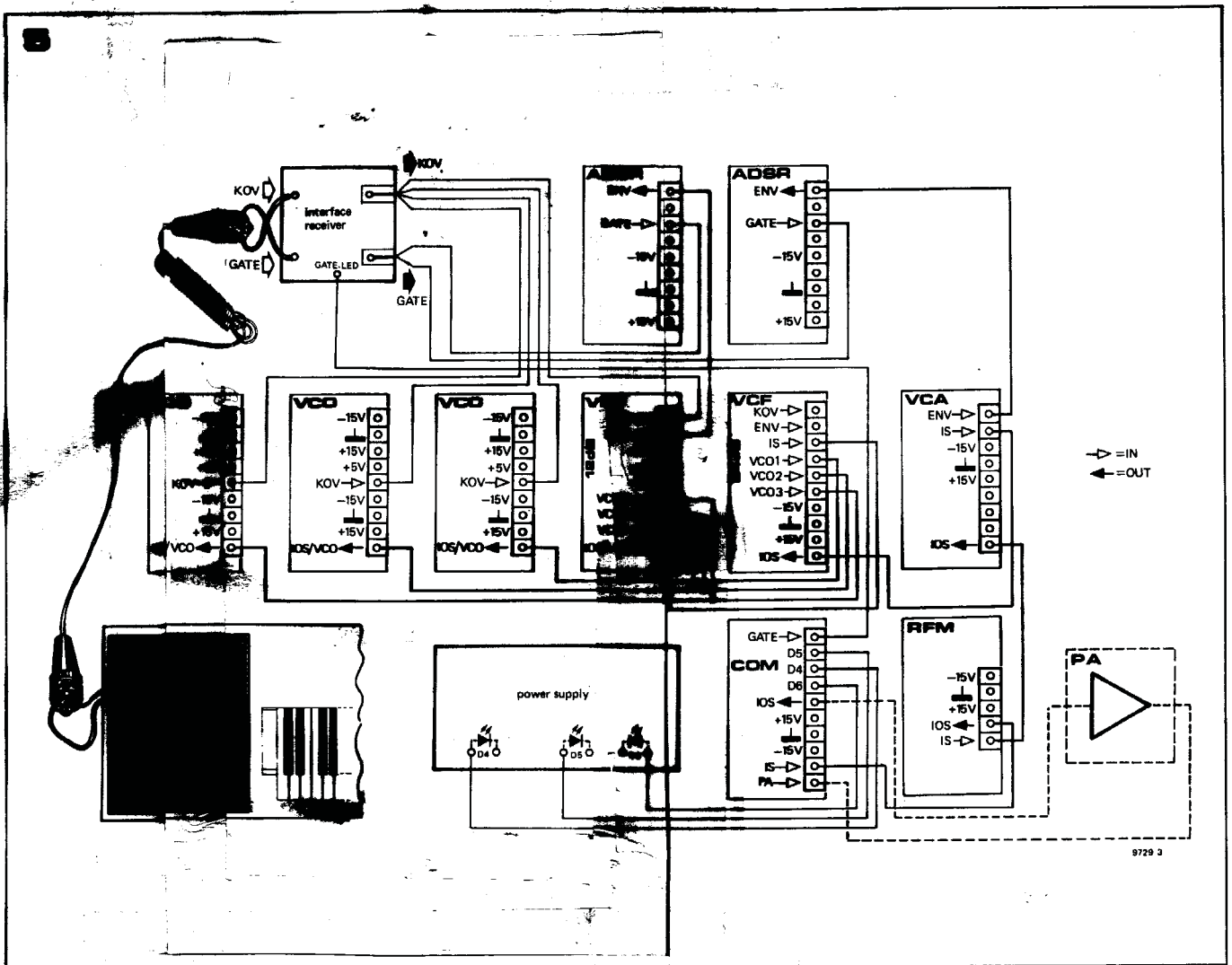

Figure 5. Inter-module wiring for the basic Formant system. Supply voltage connections have been omitted for reasons of clarity. The LFO and noise modules have been omitted as the only hardwired connections they have are supply connections.

Figure 6. The 'gate-LED' output of the interface receiver can be simplified by mounting R30 in the 'D4' position.

Some readers may not wish to bring the output of a power amplifier back through the COM to output 2, since this may not be convenient especially if the synthesiser is to be used with, say, an existing hi-fi setup. In this case two options are open. Output sockets 1 and 2 can simply be connected in parallel or alternatively output socket 2 can be wired direct to input IS to provide an output signal unaffected by the tone and volume controls.

It is not intended to provide a design for an output power amplifier since several good designs have already been published in Elektor. However, a few hints on the mounting of such an amplifier will not go amiss. As mentioned earlier, the power amplifier should not be mounted in a plug-in module since it may then cause thermal problems. It should preferably be mounted at the back of the module cabinet with the output transistors mounted on heatsinks whose fins are external to the module housing. The Formant power supply is not intended to supply current for a power amplifier, so a separate power supply will be required. The mains transformer should be mounted as far away as possible from the Formant modules to reduce hum pickup (the same applies to the Formant mains transformer).

The COM can be tested by feeding in a signal from one of the VCOs and monitoring it on an oscilloscope to check that the waveform is undistorted. The gain of the COM output stage, A4, can be varied between about 1.8 and 11 by means of P5. This preset should be adjusted so that full drive of the headphones or power amplifier is obtained with the volume control turned fully up (clockwise).

Complete wiring diagram

The interwiring between modules for the basic Formant system is given in figure 5, but readers wishing to build a more extensive system can expand this as required.

For clarity the supply wiring is not shown, but the wiring method already mentioned must be adhered to, i.e. each module should have separate supply leads from its socket back to the 'star' connection points (busbars) on the power supply module. The temptation to simplify the wiring by simply linking between the supply pins of the modules should be avoided as this will cause interaction between modules.

The 'Noise' and 'LFOs' modules are not shown in figure 5, since the supply wir-

ing is the only connection to these modules.

Again for clarity, the full pinout of each module edge connector is not shown, but the connections are shown in the correct sequence working down from the top edge of each module.

One small modification is required to the interface receiver printed circuit board (chapter 3) in order that the gate LED can be wired with only a single link. R30 on the interface receiver board is mounted in the space provided for D4 as shown in figure 6. A single wire is then connected from the lower pad to which R30 was originally connected to the appropriate pin of the COM socket. Without this modification two leads would have to be brought out to D4.

Patchcords

Due to the hardwired interconnections between modules, Formant is perfectly playable without any of the front panel patching sockets being used. However, for effects such as vibrato and tremolo, patchcords are used to connect the outputs of the LFO module to the VCOs or VCA. These can easily be 'home-made' - see chapter 1 of Part 2.