

formant

music synthesiser

description,
design,
construction and
introduction to
playing techniques

Elektor publishers Ltd.

C. Chapman

elektor

formant music synthesiser

description, design,
construction and introduction
to playing techniques

C. Chapman

second edition

Elektor publishers Ltd.

Preface

In the May 1977 issue of Elektor there appeared the first of a series of articles devoted to the Formant - a sophisticated music synthesiser whose performance was on a par with that of many commercial models but which was designed for home construction and could be built for a fraction of their cost. It quickly became apparent that there was tremendous interest in the project. Many readers have since completed construction of the Formant, and their experiences have been entirely positive. The basic modular design concept, which allows the constructor to build as many (or as few) modules as his budget permits, has proven extremely successful, and despite their complexity, an almost 100% reproducibility in the performance of the circuits has been achieved.

In view of the continued popularity of the project, we have decided to gather together and reproduce the original articles describing the design and construction of the Formant. At the same time, we have taken this opportunity to explore the musical capabilities of the Formant in somewhat greater detail than was originally permitted. A synthesiser can be a difficult instrument for the beginner to master. For this reason Part 2 of the book consists of an introduction to the techniques of actually playing the Formant. The characteristics of each module are discussed, and basic control settings for the simulation of specific instruments are described.

A novel feature of the book is that it is accompanied by a demonstration cassette, which allows the Formant enthusiast to hear for himself what the results of certain control settings should sound like and which provides some idea of the enormous musical scope of the instrument.

The availability of printed circuit boards and front panels for each of the modules makes the Formant a true home construction project and ensures that the enthusiast will have a finished instrument whose appearance he can be proud of.

first edition 1979
second edition 1981

The circuits published are for domestic use only. The submission of designs or articles to Elektor implies permission to the publishers to alter and translate the text and design, and to use the contents in other Elektor publications and activities. The publishers cannot guarantee to return any material submitted to them. All drawings, photographs, printed circuit boards and articles published in Elektor are copyright and may not be reproduced or imitated in whole or part without prior written permission of the publishers.

Patent protection may exist in respect of circuits, devices, components etc. described in this book.
The publishers do not accept responsibility for failing to identify such patent or other protection.

Copyright © 1979 Elektor publishers Ltd. Canterbury.
Printed in the Netherlands.
ISBN 0 905705 04 1

Contents

Preface	3
PART 1	
FORMANT - DESCRIPTION AND CONSTRUCTION	
Chapter 1	7
Introduction. Synthesisers are something of a mystery to many people, this chapter therefore provides an introduction to the basic principles of synthesisers in general.	
Chapter 2	11
Keyboard and Keyboard Interface. The description of the Formant begins with the keyboard and associated electronics.	
Chapter 3	19
Keyboard Construction and Power Supply. In addition to constructional details of the keyboard case, this chapter commences the description of the voltage-controlled module unit, starting with the power supply and a discussion of the module case.	
Chapter 4	29
VCO. The VCOs (Voltage Controlled Oscillators) provide a choice of 5 different waveforms, and possess an exponential control characteristic (1 V per octave). This chapter describes the basic design of the VCOs and discusses the musical significance of this module.	
Chapter 5	36
Construction of the VCO. Construction, testing and adjustment of the VCOs.	
Chapter 6	44
12 dB VCF. The first of the filter modules, which tailor the frequency spectrum of the VCO signal to provide the desired harmonic structure. The 12 dB VCF offers a choice of 4 filter functions (highpass, lowpass, bandpass or notch), and variable Q.	
Chapter 7	50
24 dB VCF. For certain applications it is desirable to have a filter with an extremely steep roll-off. The design presented in this chapter offers a choice of highpass or lowpass functions, and a filter slope of either 6, 12, 18 or 24 dB per octave.	
Chapter 8	58
Resonance Filter Module. The RFM is designed to allow more realistic simulation of conventional musical instruments by providing the fixed bandpass resonances which are an important determining factor in the timbre of mechanical tone generators. The module contains three separate resonance filters, whose centre frequency, Q and gain can be independently varied.	
Chapter 9	64
ADSR. The ADSR (Attack-Decay-Sustain-Release) module is used to control the VCF and VCA and thereby control the dynamic harmonic structure and dynamic amplitude characteristics of the VCO signals.	
Chapter 10	70
VCA. The VCA (Voltage Controlled Amplifier) determines the amplitude contour of the output signal. The module in fact contains a DUAL VCA, which can be used in conjunction with an envelope shaper for dynamic control of signal amplitude and also with a low frequency modulation signal to provide tremolo.	
Chapter 11	76
LFOs and Noise Module. The LFOs (Low Frequency Oscillators) provide low frequency modulation signals for the VCOs, VCFs and VCA permitting tremolo, vibrato and other similar effects to be obtained. The NOISE module provides the basic material to synthesise a whole spectrum of sounds which have no defined pitch.	
Chapter 12	83
COM. Part 1 is brought to a close with a description of the COM (Control and Output Module), and an overall wiring diagram for the 'basic' Formant system.	

PART 2

PLAYING THE FORMANT

Basic control settings and musical tips on how to play the Formant

Introduction	88
Chapter 1. Extending the Formant	89
Chapter 2. Control settings of individual modules	89
VCOs	89
Main characteristics of the VCOs • Tuning the VCOs • Pulse width modulation (PWM) • Ring modulation using PWM • VCO Waveforms • Frequency modulation • ECV/KOV interface •	
VCFs and RFM	94
Main characteristics of the VCFs • Using the VCFs as tracking filters • Using a VCF as resonance filter • Other filter settings • Pedal-controlled Wa-Wa • RFM •	
VCA	97
Main characteristics of the VCA • Tone colour- and amplitude dynamics • Linear amplitude modulation • Expression and swell pedal •	
ADSR envelope shapers	99
Main characteristics of the ADSR module • Attack-decay contour • Attack-sustain-release contour • Attack-decay-sustain-release contour •	
LFOs	100
Noise module	100
COM	100
Chapter 3. Control Settings for the simulation of different instruments	100
Synthesiser size and musical performance • Simple flute sounds • Simple brass sounds • Realistic tone colour through resonance filtering • Improved brass sounds • Multi-voice brass sounds • Some typical synthesiser effects with no natural equivalents • Oboe, bassoon and clarinet • String instruments • Improved flute sounds • Organ sounds • Piano- and piano-related sounds • Gong-, bell- and glockenspiel sounds • Further tonal possibilities • Using the Formant with other instruments •	
Elektor Decoder	109
Elektor Print Service	109

Decoder

Semiconductor types

Very often, a large number of equivalent semiconductors exist with different type numbers. For this reason, 'abbreviated' type numbers are used in Elektor wherever possible:

- '741' stand for μ A741, LM741, MC641, MIC741, RM741, SN72741, etc.
- 'TUP' or 'TUN' (Transistor, Universal, PNP or NPN respectively) stand for any low frequency silicon transistor that meets the following specifications:

UCEO, max	20V
IC, max	100 mA
hfe, min	100
Ptot, max	100 mW
fT, min	100 MHz

Some 'TUN's are: BC107, BC108 and BC109 families; 2N3856A, 2N3859, 2N3860, 2N3904, 2N3947, 2N4124. Some 'TUP's are: BC177 and BC178 families; BC179 family with the possible exception of BC159 and BC179; 2N2412, 2N3251, 2N3906, 2N4126, 2N4291.

- 'DUS' or 'DUG' (Diode Universal, Silicon or Germanium respectively) stands for any diode that meets the following specifications:

	DUS	DUG
UR, max	25V	20V
IF, max	100mA	35mA
IR, max	1 μ A	100 μ A
Ptot, max	250mW	250mW
CD, max	5pF	10pF

Some 'DUS's are: BA127, BA217, BA218, BA221, BA222, BA317, BA318, BAX13, BAY61, 1N914, 1N4148.

Some 'DUG's are: OA85, OA91, OA95, AA116.

- 'BC107B', 'BC237B', 'BC547B' all refer to the same 'family' of almost identical better-quality silicon transistors. In general, any other member of the same family can be used instead.

BC107 (-8, -9) families:

BC107 (-8, -9), BC147 (-8, -9), BC207 (-8, -9), BC237 (-8, -9), BC317 (-8, -9), BC347 (-8, -9), BC547 (-8, -9), BC171 (-2, -3), BC182 (-3, -4), BC382 (-3, -4), BC437 (-8, -9), BC414

BC177 (-8, -9) families:

BC177 (-8, -9), BC157 (-8, -9), BC204 (-5, -6), BC307 (-8, -9), BC320 (-1, -2), BC350 (-1, -2), BC557 (-8, -9), BC251 (-2, -3), BC212 (-3, -4), BC512 (-3, -4), BC261 (-2, -3), BC416.

Resistor and capacitor values

When giving component values, decimal points and large numbers of zeros are avoided wherever possible. The decimal point is usually replaced by one of the following abbreviations:

p (pico-) = 10^{-12}
 n (nano-) = 10^{-9}
 μ (micro-) = 10^{-6}
 m (milli-) = 10^{-3}
 k (kilo-) = 10^3
 M (mega-) = 10^6
 G (giga-) = 10^9

A few examples:

Resistance value 2k7: 2700 Ω .
 Resistance value 470: 470 Ω .
 Capacitance value 4p7: 4.7 pF, or 0.000 000 000 004 7 F. . . .
 Capacitance value 10n: this is the international way of writing 10,000 pF or .01 μ F, since 1 n is 10^{-9} farads or 1000 pF.
 Resistors are $\frac{1}{2}$ Watt 5% carbon types, unless otherwise specified.

The DC working voltage of capacitors (other than electrolytics) is normally assumed to be at least 60 V. As a rule of thumb, a safe value is usually approximately twice the DC supply voltage.

Test voltages

The DC test voltages shown are measured with a 20 k Ω /V instrument, unless otherwise specified.

U, not V

The international letter symbol 'U' for voltage is often used instead of the ambiguous 'V'. 'V' is normally reserved for 'volts'. For instance: $U_b = 10$ V, not $V_b = 10$ V.

Mains voltages

No mains (power line) voltages are listed in Elektor circuits. It is assumed that our readers know what voltage is standard in their part of the world!

Readers in countries that use 60 Hz should note that Elektor circuits are designed for 50 Hz operation. This will not normally be a problem; however, in cases where the mains frequency is used for synchronisation some modification may be required.

formant

the elektor

music synthesiser

chapter 1

introduction

Formant - the Elektor music synthesiser - is an instrument of advanced specification that bears comparison with many commercially available synthesisers, but at a fraction of the cost.

As synthesisers are something of a mystery to many people this first chapter provides an introduction to the basic principles of synthesisers in general.

A synthesiser may be defined as an electronic musical instrument whose tonal characteristics can be varied at will by the musician. This immediately makes the synthesiser different from conventional musical instruments, whose tonal characters are fixed by their physical construction. It also makes the synthesiser different from an electronic organ, since the latter has a fixed set of voices, generally imitative of conventional organ voices, whereas the synthesiser has no fixed tonal characteristics. The synthesiser may be used to imitate conventional instruments, but on the other hand it may also produce sounds that cannot be produced by any conventional acoustic instrument, and which can be generated only by electronic means.

The synthesiser then, is an extremely versatile instrument, and it is a great pity that it is often used to provide monotonous background accompaniment to beat music, or as a 'band in a box' to produce television advertising jingles. Fortunately the capabilities of synthesisers have been fully exploited by musicians such as W. Carlos, K. Emerson, P. Moraz et al.

Principles of the Voltage Controlled Synthesiser.

The concept of the voltage-controlled synthesiser and related circuits was originated by Robert A. Moog. Any sound can be characterised by just three

time dependent parameters, namely pitch, tone colour and volume, or to put it in electronic terms, fundamental frequency, harmonic content and amplitude. If these three parameters can be precisely controlled for the duration of a particular sound then that sound can accurately be synthesised. In practice this is obviously limited to fairly simple 'musical' and related sounds.

A synthesiser thus requires three basic circuit blocks: oscillators to generate sounds of the required pitch, filters to produce the required harmonic content, and amplifiers to obtain the required amplitude. Since the three parameters may vary during the existence of a particular sound there must be some means of rapidly controlling the characteristics of these circuit blocks, which is where the concept of voltage control comes in. The *pitch* of a voltage-controlled oscillator (VCO) may be varied by changing the control voltage applied to it. The *cutoff-frequency* of a voltage-controlled filter (VCF) may similarly be varied, as may the *gain* of a voltage-controlled amplifier (VCA).

Exponential Voltage Control

The fundamental design parameter of a synthesiser is the control voltage versus frequency characteristic of VCO's and VCF's. In many applications a linear characteristic is required, i.e. n volts per Hz. However, musicians are concerned

Figure 1. A comprehensive commercial music synthesiser, the Modell 'Sample System 4'.

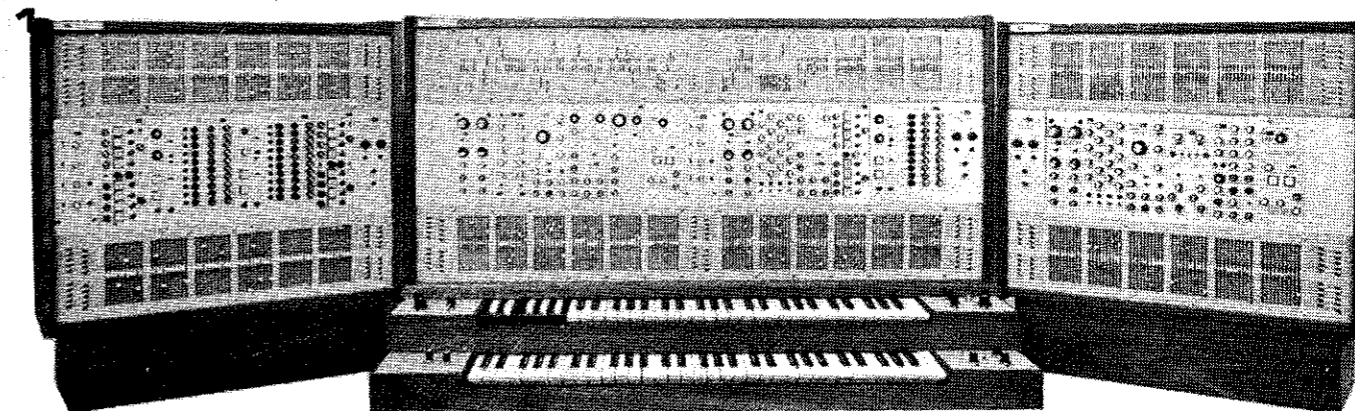

SAMPLE SYSTEM 4

9720-1

Elektor Printed Circuit Board Service

A complete set of printed circuit boards and front panels for the Formant are available direct from Elektor Publishers Ltd. The boards are pre-etched and ready-drilled. For optimum legibility even under extreme lighting conditions the pre-drilled metal front panels are sprayed matt black with the legends and scales printed in white.

Front panels

Module	EPS No.
Interface	9721-F
VCO	9723-F
VCF (12 dB)	9724-F
VCF (24 dB)	9953-F
RFM	9951-F
ADSR	9725-F
DUAL VCA	9726-F
LFOs	9727-F
NOISE	9728-F
COM	9729-F

For price information see the latest edition of Elektor, or apply direct to the publishers.

Printed Circuit Boards

Module	EPS No.
Keyboard Interface	9721-1
Interface Receiver	9721-2
Power Supply	9721-3
Keyboard Divider (one octave)	9721-4
VCO	9723-1
12 DB VCF	9724-1
24 dB VCF	9953-1
RFM	9951
ADSR	9725-1
DUAL VCA	9726-1
LFO	9727-1
NOISE	9728-1
COM	9729-1

not with linear frequency relationships but with musical intervals, the basic one of these being the octave. For each octave increase in pitch the frequency of a note doubles. This means that if the absolute frequency in Hertz is plotted against the relative frequency in octaves an exponential curve results, as shown in figure 2. It therefore seems more logical from a musical point of view to have a linear control voltage versus octaves characteristic. Figure 3 shows a control characteristic of 1 octave/volt (which is the standard generally adopted). This exponential control has several other advantages which will be discussed later.

An exponential (octave linear) control characteristic may be achieved by preceding a frequency linear VCO or current-controlled oscillator by an exponential generator whose output voltage or current doubles for each one volt increase in input voltage (figure 4). The exponential generator can be preceded by a summing amplifier into which is fed the main control voltage along with other voltages such as a D.C. offset voltage to transpose up and down the scale, and/or A.C. modulating voltages to produce vibrato effects.

Keyboard Voltage Control

In order to play the synthesiser there must be some method of feeding varying control voltages into the instrument. Since most (Western) musical instruments are tuned and played in the tempered tonic scale it seems logical that a synthesiser should conform to this scale, and the most obvious choice of 'input terminal' is a normal organ keyboard with electrical contacts.

The keyboard circuit (figure 5) consists of a potential divider chain comprising

equal value resistors, fed from a current source. Since there are twelve semitone intervals (and hence twelve key contacts) to an octave, each resistor has a potential difference of 1/12 volt across it. Depressing a particular key connects the voltage on that key contact out to the common bus rail, and thence to the voltage-controlled circuits.

Transposition

Like an electronic organ, a synthesiser keyboard has only a limited compass (three octaves in the case of Formant). In an organ a wider compass is obtained simply by selecting voices with a lower register. In a synthesiser the compass is extended by adding a D.C. offset voltage to the VCO input (or to the keyboard output) to transpose the range of the keyboard. This is shown in figure 6. An offset of +1 volt transposes the range up one octave, while an offset of -1 volt transposes it down one octave.

Advantages of exponential control

Figure 7 illustrates the principal advantage of exponential control, which is chording. This shows three VCO's each with three summing inputs. The first input of each VCO is commoned and connected to the keyboard. The second input of each VCO is connected to an independently variable D.C. offset voltage, while the third inputs are all commoned to another variable D.C. offset voltage. Suppose that the independent offsets are adjusted so that the adjacent VCO frequencies are one octave apart, e.g. 1 kHz, 2 kHz and 4 kHz. If the keyboard input increases by one volt then the frequencies will increase to 2 kHz, 4 kHz and 8 kHz respectively, which are still one octave

apart. This would not be the case with a linear VCO. As an example, suppose the first frequency increases by 1 kHz to 2 kHz; the second will also increase by 1 kHz (to 3 kHz), and the third will increase to 5 kHz. This 2-3-5 kHz group no longer shows an octave relationship. Of course, with exponential control one is not confined simply to octave chords. By adjusting the independent offset controls the VCO's may be set up in any musical interval relationship. Additionally any number of VCO's may be employed. The commoned third inputs of the VCO's permit a common offset voltage to be fed to each VCO to transpose the whole chord up or down the scale. A further possibility is to add an offset voltage to the keyboard output to transpose the pitch of the entire synthesiser. This may seem a little confusing at first, but is not so in practice. To summarise:

1. VCO's may be arranged in chording groups. The pitch of each VCO may be varied relative to other VCO's within a group to obtain the required chord, by adjusting the independent tuning controls.
2. The pitch of a chording group may be varied by adjusting the chord transposition control.
3. The pitch of the entire synthesiser may be transposed by an overall transposition control that adds a variable offset voltage to the keyboard output.

Voltage Controlled Filters

Voltage controlled filters employed in synthesisers are commonly of the lowpass type. A block diagram of their operation is given in figure 8. A D.C. voltage sets the cutoff frequency relative to the pitch of the VCO's, while a control voltage derived from the keyboard shifts this cutoff point up or

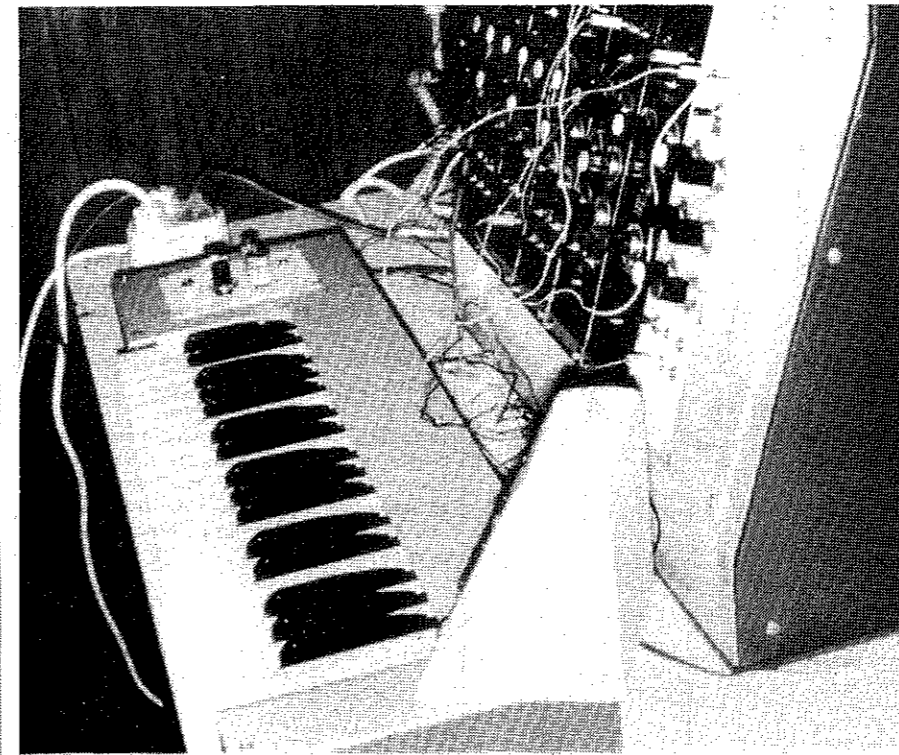

down according to which note is played, so that all notes played, whether high or low, have the same harmonic content. Natural sounds are characterised by dynamic changes of tone colour. A note may start by having a 'bright' character with a large proportion of the higher harmonics, but these then decay rapidly leaving only the fundamental and lower harmonics. Provision must therefore be made to vary the cutoff point during the note, e.g. the cutoff point might initially start off at a fairly high frequency, which would decrease with time to cause the decay of the higher harmonics. This is achieved by means of an envelope shaper which generates a varying voltage having the required characteristics. The envelope shaper is controlled by a gate pulse which is derived from a second set of contacts on the keyboard. The voltage versus cutoff frequency characteristic of the VCF's is again made exponential by preceding the control input of the VCF with an exponential generator.

Voltage controlled amplifiers

The VCA's are simply amplifiers whose gain may be varied by a control voltage. Their function is to control the duration of a sound, and also its dynamic amplitude characteristics, i.e. its attack, sustain and decay. The VCA is again controlled by an envelope shaper whose output voltage has a form corresponding to the amplitude envelope of the required sound. The VCA of course has no control voltage input from the keyboard, since the amplitude of all notes must remain the same and does not depend upon the frequency of the note being played.

The envelope shaper which controls the VCA is itself controlled by a gate pulse

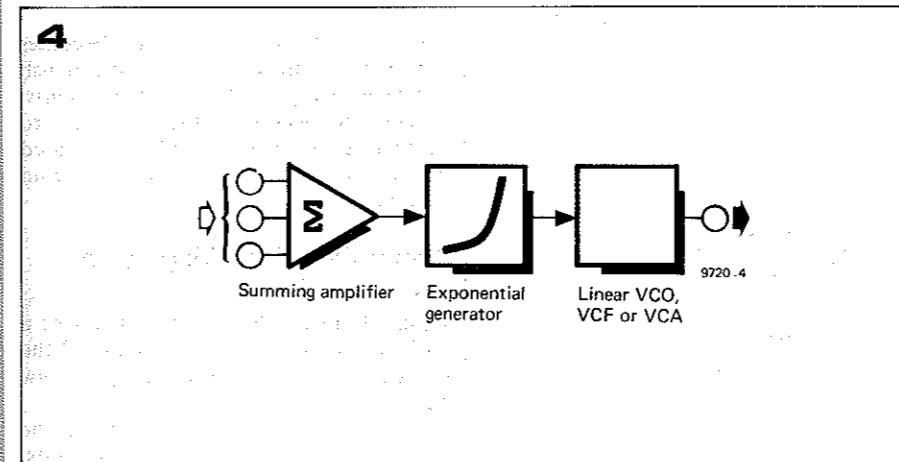
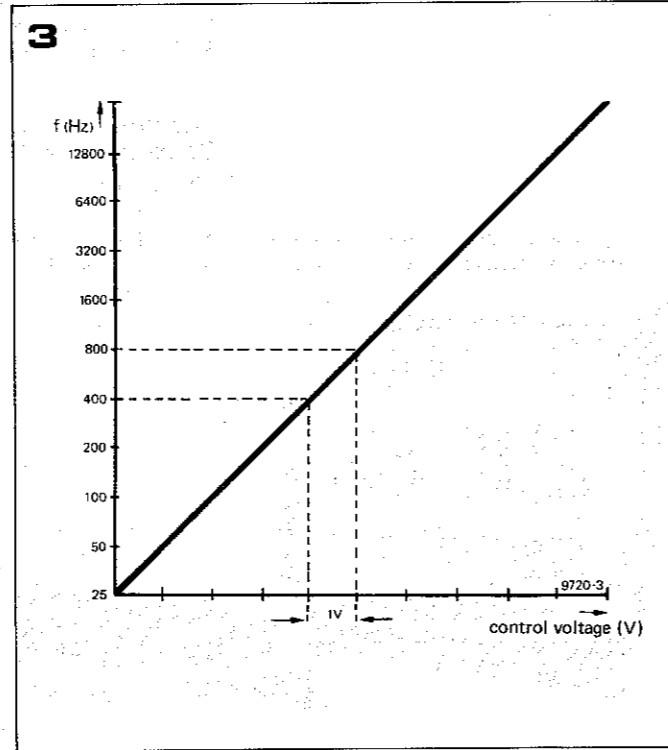
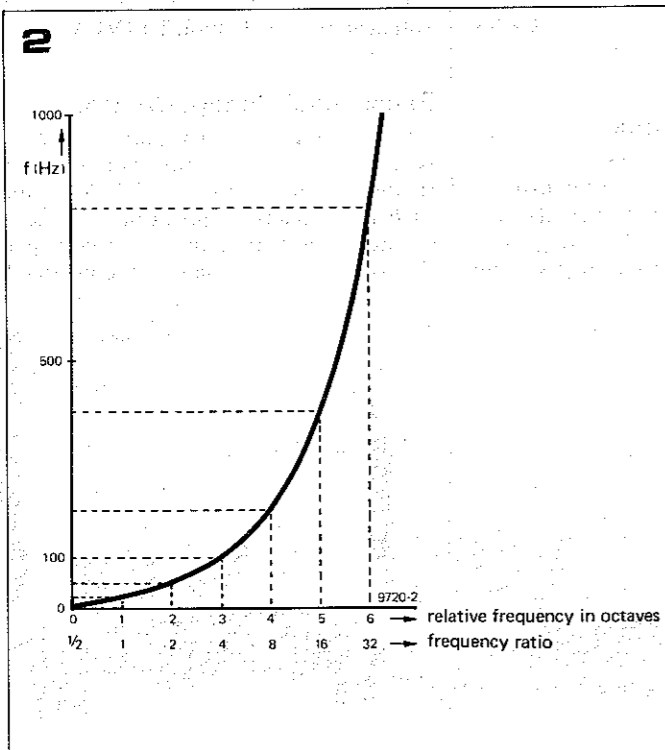

Figure 2. Showing the exponential relationship between relative frequency in octaves and absolute frequency in Hertz.

Figure 3. In common with other synthesisers, Formant has an exponential or octave-linear control characteristic of 1 octave/volt, i.e. if the control voltage is increased by 1 volt the frequency doubles.

Figure 4. Principle of a voltage-controlled synthesiser module according to Moog. This forms the basis of the voltage-controlled modules in Formant.

Figure 5. Showing how the control voltage is derived from the keyboard using a resistive potential divider.

Figure 6. By adding a DC offset voltage to the summing input of the VCO along with the keyboard voltage, the frequency range can be transposed. For example, an offset of +1 V makes the note one octave higher than that actually played on the keyboard. An offset of -1 V would make it one octave lower.

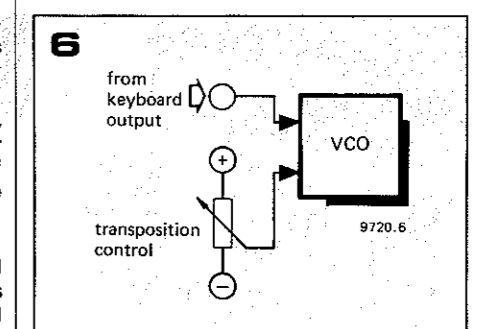
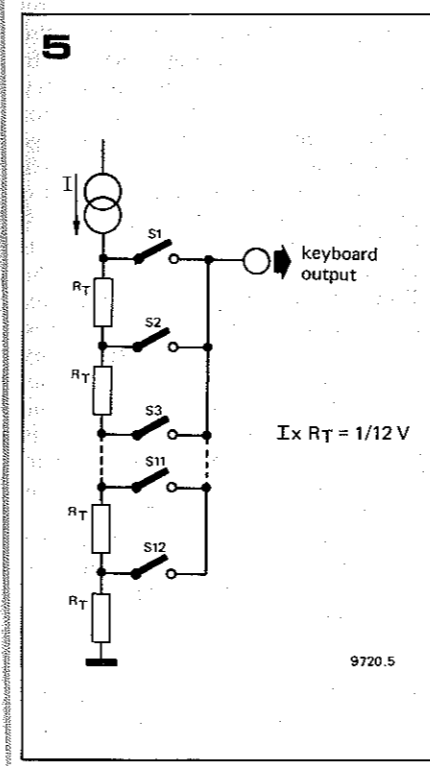

derived from the second contact set on the keyboard, and this determines the duration of the note played.

In the case of both the VCF's and VCA's the output voltage characteristic of the controlling envelope shaper (i.e. the manner in which the envelope voltage varies with time) can be adjusted by the musician. This is extremely important since the dynamic characteristics of a sound largely determine the character of the sound. Returning to conventional musical instruments as an example, if the attack transient at the beginning of a note is removed and only the steady

7

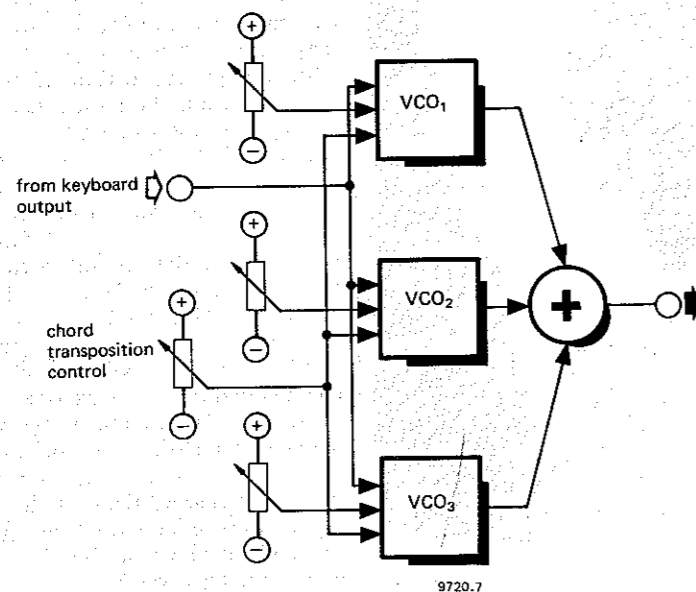

Figure 7. To play a chord, the offset of several VCO's may be adjusted to give the required musical intervals. They can then be controlled simultaneously by the keyboard, and may also be transposed together by a common D.C. voltage. This is known as 'chord transposition'.

Figure 8. The voltage-controlled filter (VCF) is controlled in exactly the same manner as the VCO. The keyboard controls its cutoff frequency, which can also be 'transposed' by a D.C. offset voltage. The third input allows dynamic changes of cutoff frequency during the playing of a note by means of an envelope shaper.

Figure 9. Layout of a basic synthesiser. Several additional blocks are shown such as low-frequency oscillators and noise generator to modulate the voltage-controlled modules, and a noise generator to produce effects such as wind, rain etc.

note is played then it becomes extremely difficult to distinguish between many orchestral instruments. Indeed, it becomes difficult even to determine whether sounds so treated belong to string, brass or woodwind families.

Synthesiser Block Diagram and Additional Circuits

Figure 9 shows the block diagram of a basic synthesiser, which contains all the circuits previously described plus a few extras.

At the bottom of the diagram is the keyboard and its interface circuits. These consist basically of the control voltage potential divider, the gate pulse generator and the envelope shapers. In addition there are low-frequency oscillators that provide a signal for periodic modulation of the voltage controlled circuits (e.g. for effects such as vibrato) plus a noise voltage generator to provide random modulation.

The block containing the VCO's needs little explanation, except for the addition of a noise generator. Since this generates a stochastic signal of no fixed pitch its frequency is not controlled by the keyboard, but the noise signal can be processed by passing through the VCF's and VCA's to produce effects such as wind, water, rain, thunder, steam trains, applause etc., as well as totally unnatural sounds.

The VCO and noise signals are passed through the VCF and then through the VCA, both of which are controlled by the envelope shapers.

Tonal Character of Synthesisers

The foregoing description of the basics of synthesisers can hardly give any

9

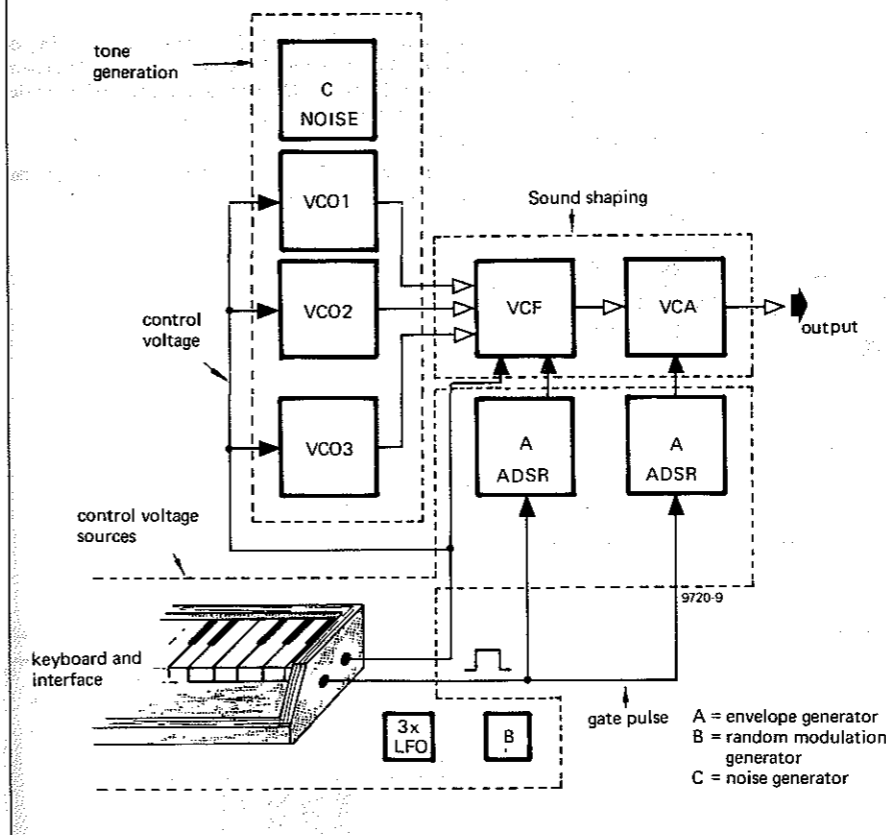

impression of the range of tonal possibilities available with a synthesiser. To begin with, it should not be imagined that the sound produced by a synthesiser is like that produced by an

electronic organ. A synthesiser has much more in common with conventional musical instruments. Whereas the sound of an electronic organ has a fairly static character, a synthesiser is much

more lively and dynamic. The reasons for this are twofold. Firstly, a synthesiser permits precise control of the dynamic characteristics of the sounds produced, whereas an electronic organ (unless it is an expensive one) has only fixed attack and decay characteristics that must suffice for every voice. Secondly, whereas most electronic organs are fixed phase, the synthesiser, with its phase-independent VCO's, can much better produce more 'natural' sounds, which have varying phase patterns.

Literature

- Moog R.A. 'Voltage-controlled electronic music modules'. *JAES* 13.3 July 1965.
- 'A voltage-controlled low-pass, high-pass filter for audio signal processing'. *AES Preprint* 413, 1965.
- Burhans R. 'Simplified educational music synthesiser'. *JAES* 19.2, February 1971.
- Orr. T. and Thomas D.W., 'Electronic Sound Synthesiser'. *Wireless World*, August-October 1973.
- Simonton J. 'Build a modular electronic music synthesiser'. *Radio-Electronics*, May-October 1973.
- Shaw G. 'P.E. Sound Synthesiser'. *Practical Electronics*, February 1973-February 1974.
- Tünker H. 'Electronic-Pianos and Synthesiser'. *Franzis-Verlag*, 1975. Nr. 302 (RPB Serie).

8

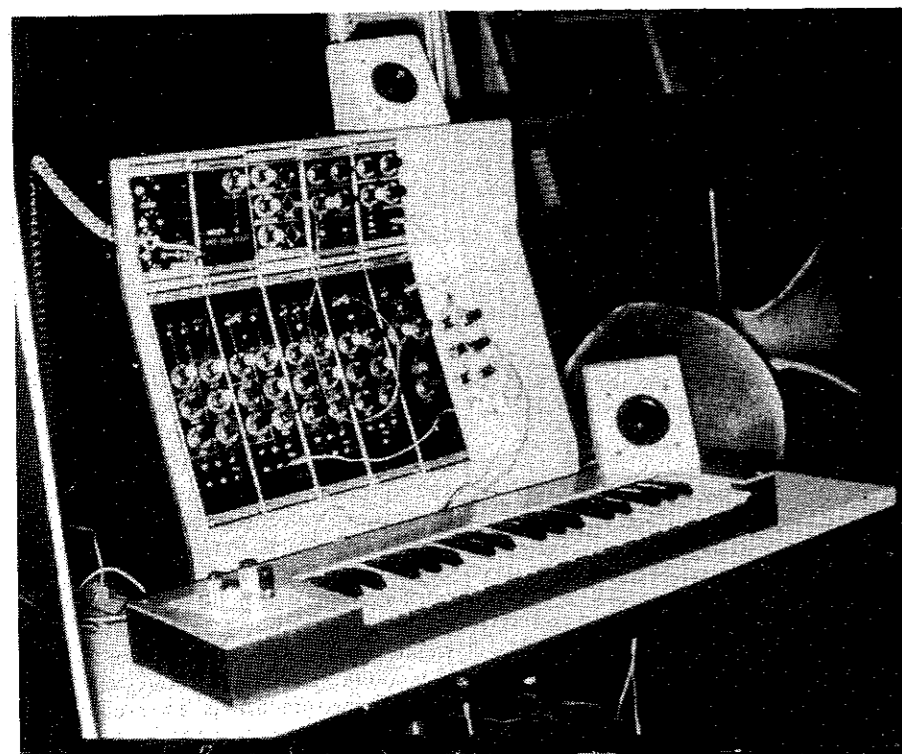
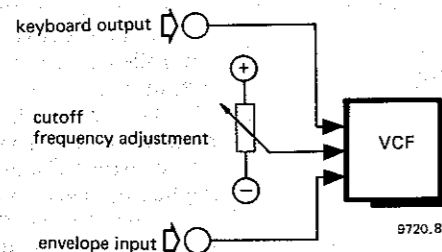

chapter 2

keyboard and keyboard interface

Having discussed the basic principles of synthesisers, we can now proceed to a description of the Formant itself, starting with the keyboard and associated electronics.

Before going any further it must be stressed that 'Formant' is not a suitable project for the beginner. The complexity of the synthesiser demands a high degree of competence in soldering p.c. boards and interwiring if an unacceptably large number of faults are not to arise. Some knowledge of operational amplifier basics is also almost essential. Nor should the project be undertaken by anyone who does not have access to an oscilloscope, a good multimeter, and preferably a digital voltmeter.

Top grade components are also a must. Where specified, 1% metal film or metal oxide resistors must be used. All other resistors should be good quality 5% carbon film types, while capacitors (except where the capacitance demands an electrolytic) should be low loss, low leakage types such as polycarbonate, polyester or polystyrene. Ceramic capacitors should not be used. Semiconductors too should be first-grade devices from a reputable source, not 'unmarked, untested' manufacturer's rejects. The temptation to save money by buying dubious components should be avoided,

as unsatisfactory performance will almost certainly be the result.

The synthesiser comprises two separate units, the module unit containing VCO's, filters, power supplies etc, and the manual unit containing the keyboard. These two units are interconnected by cables with plug and socket terminations and can be separated for transportation or storage.

The keyboard is a 37-note C to C keyboard fitted with Kimber-Allen two-pole normally open contact blocks. The keyboard used in the prototype was an SKA type. This keyboard is recommended for the project and the descriptions given will relate to it, though other types may also be suitable. The keyboard consists of an aluminium chassis with dimensions similar to those given in figure 1, to which the keys and return springs are assembled. The key contacts are depressed by a plastic actuator on the underside of each key, which protrudes through a hole in the chassis (see figure 1c). Contact blocks are supplied separate from the keyboard, and the first task is to assemble

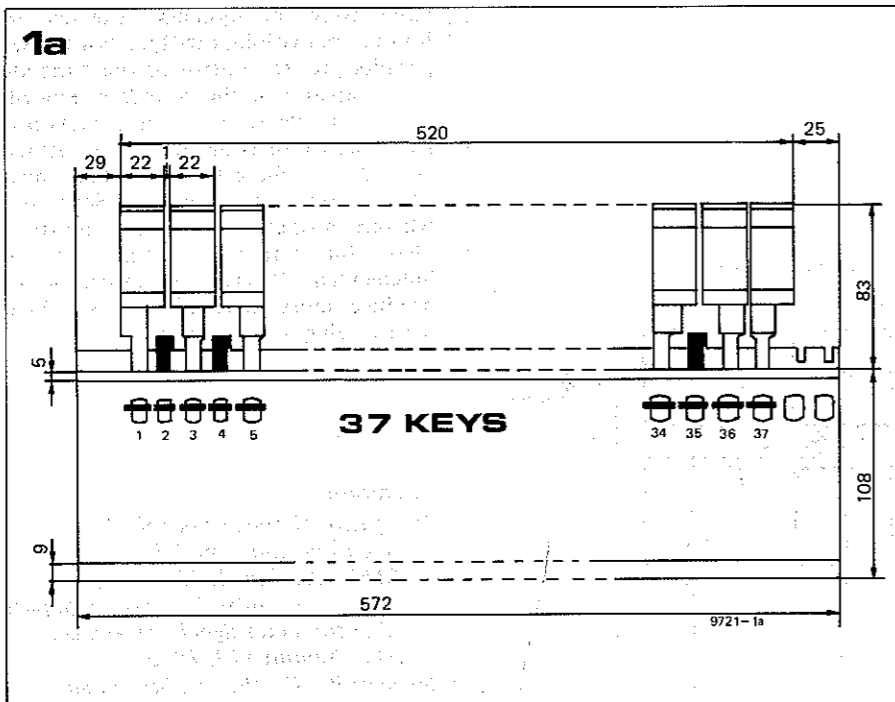

Figures 1a, 1b and 1c. Mechanical details of the SKA keyboard. (A) Keys. (B) Contact actuator. (C) Chassis.

Figures 2a and 2b. Showing the mounting of the key contact blocks. (A) Key. (B) Actuator. (C) Chassis. (D) Contact block. (E) Divider board. (F) Spacer.

Figure 3. Circuit of the keyboard divider chain and current source.

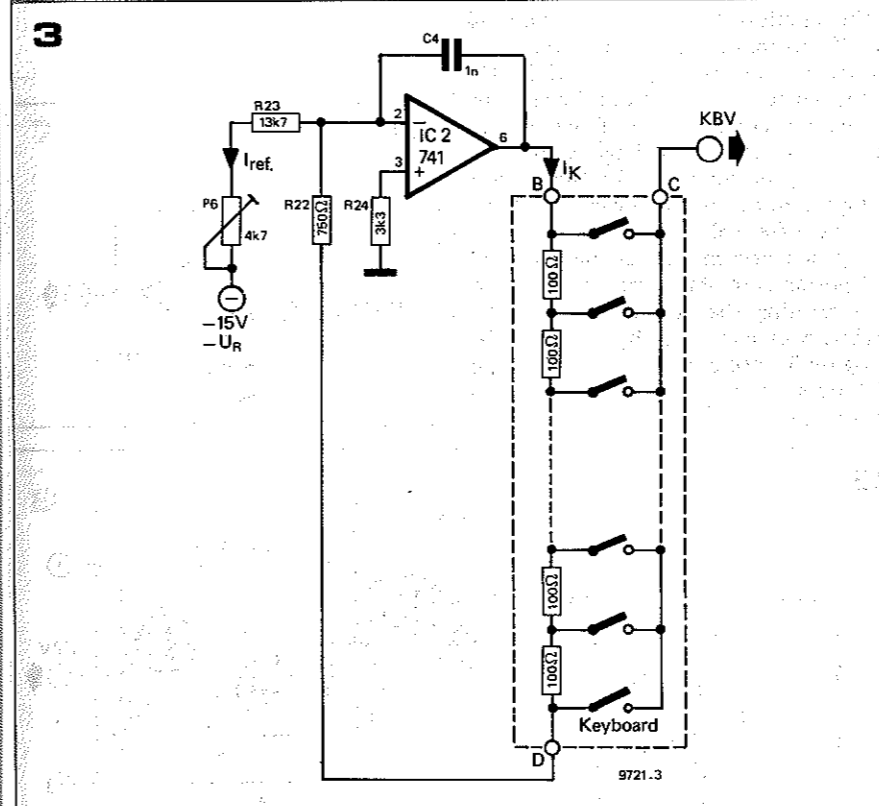
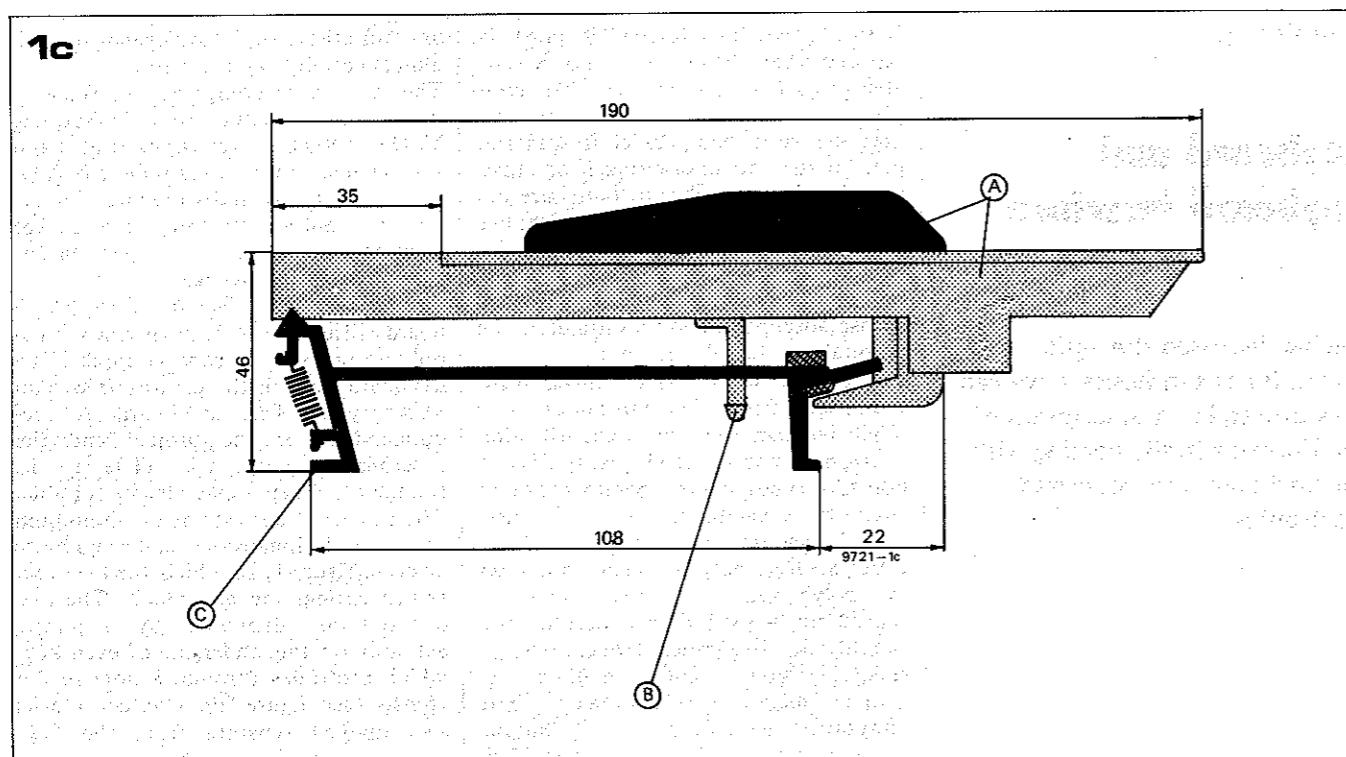
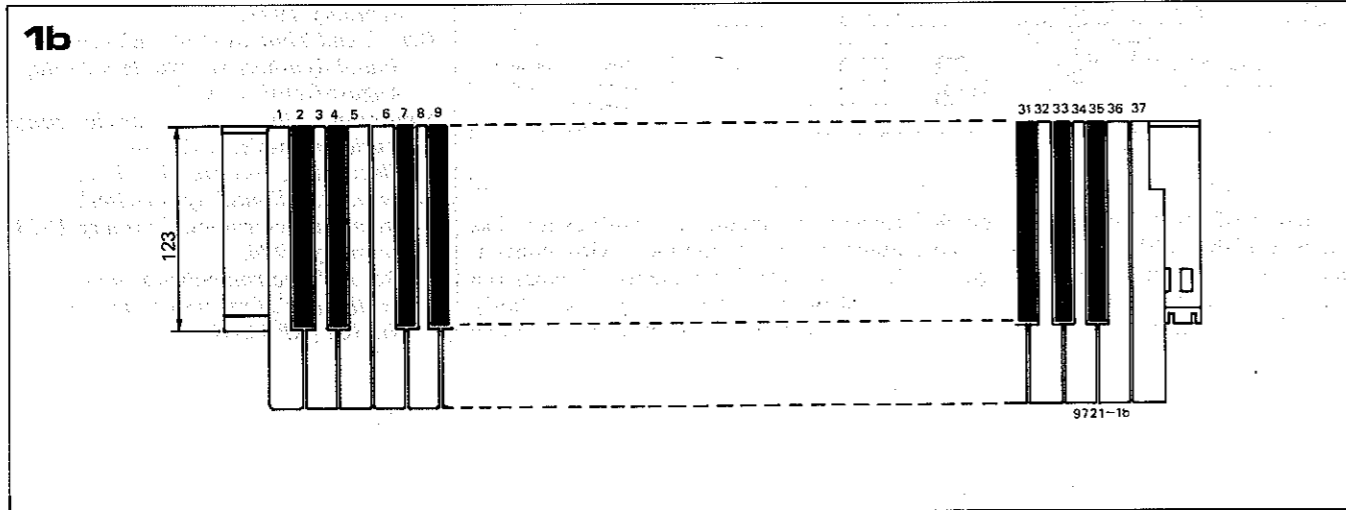
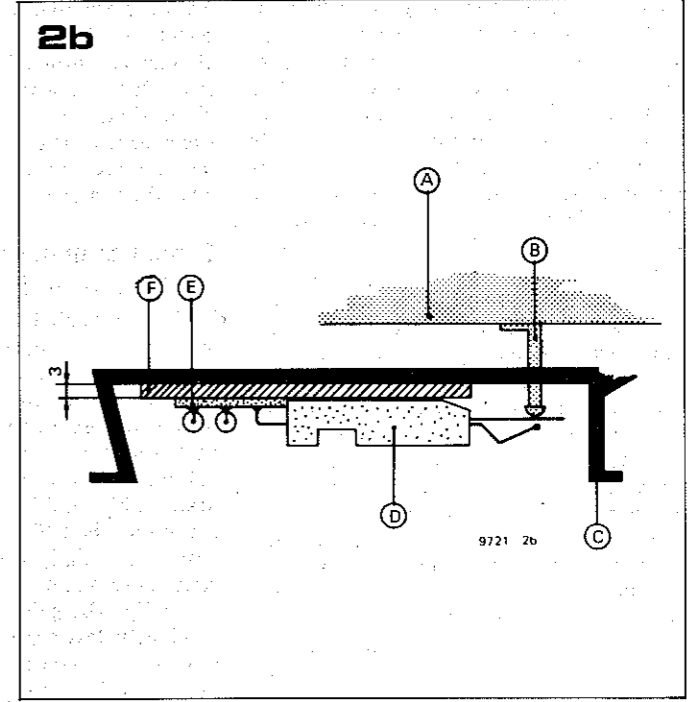
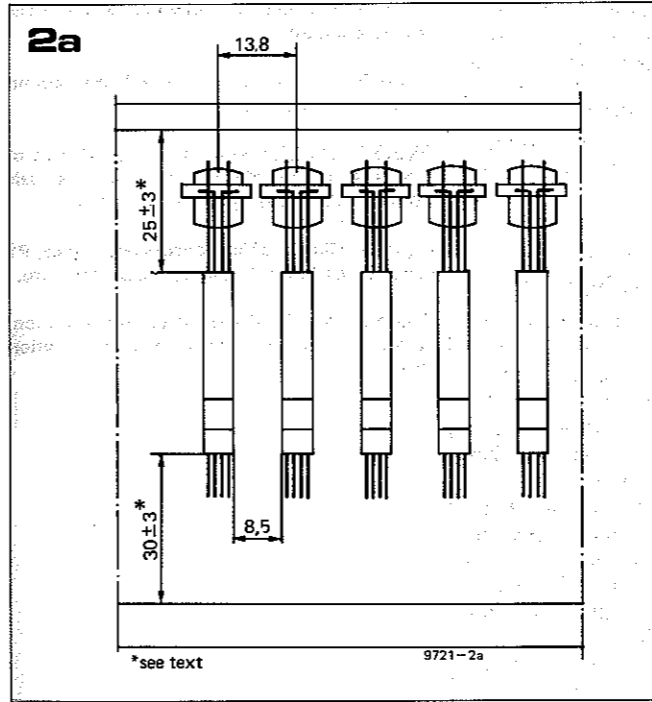

the contacts to the underside of the chassis as shown in figures 2a and 2b. The contact blocks must be spaced away from the chassis so that the actuator (A) just touches the movable contact with the key in the rest position. A strip of 3 mm thick perspex or other plastic makes a suitable spacer (F). The simplest method of fixing the contact blocks in position is to glue them to the plastic spacer using quick setting epoxy adhesive, taking care not to get any adhesive into the 'works' of the contact block. For those preferring a more easily serviceable assembly the slot in the underside of the contact will accept a rectangular section metal strip

which will clamp the contacts to the chassis using nuts and bolts.

Keyboard interface

The principle of the synthesiser keyboard, which was briefly explained in chapter 1, is shown in figure 3. The function of one contact-set on the keyboard is to provide a control voltage to the voltage-controlled modules of the synthesiser. Each key can be used to switch a voltage from a particular point in a potential divider comprising equal value close tolerance resistors fed from a constant current source. The control characteristic of the Formant is 1 octave/volt so each resistor in the

chain must drop 1/12 V giving a step of 1/12 V per semitone.

In figure 3 the constant current source is built around IC2, a 741 op amp. From the -15 V stabilised supply a constant current flows through P6 and R23. Since only a negligible bias current can flow into the inverting input of the 741, this same current must also flow out of the op amp output and through the potential divider chain back to the inverting input. Since R24 holds the non-inverting input at ground potential, the voltage at the junction of R22 and R23 is also zero - a 'virtual earth' point. P6 can be adjusted to give a current of 833 μ A or a voltage drop of 1/12 V across each 100 Ω resistor, i.e. 83.3 mV. In practice the voltage will not be exactly 83.3 mV but will be somewhat higher to compensate for voltage losses in other parts of the circuit.

It may seem rather strange to use a stabilised reference voltage to produce a constant current which in turn is used to produce a constant voltage. Why not simply feed the potential divider from a constant voltage in the first place? The answer is quite simple. Since the synthesiser is a monophonic instrument only one note can be played at once. If the divider chain were fed from a voltage source and several keys were depressed simultaneously, either by accident or intentionally, then part of the divider chain would be shorted out, increasing the voltage drops across the remaining (unshorted) resistors and giving a discordant note. Feeding from a constant current source means that, even if part of the chain is shorted out the voltage drops across the remaining resistors will stay correct and the note sounded will actually be the lowest note of those played.

Sample and hold circuit

It is not possible directly to use the

output voltage of the keyboard to control the synthesiser, since immediately a key is released that voltage disappears abruptly, and so would any tone that was controlled by it, making effects such as sustain impossible. For this reason the output voltage of the keyboard is stored in a sample and hold circuit. This consists basically of a switch and a capacitor connected to the input of an op amp in voltage follower configuration. When the switch is closed the capacitor charges rapidly to the same level as the input voltage. The op amp output also assumes this level. If the switch is now opened, then assuming the op amp has a high input resistance, the capacitor can discharge only extremely slowly, so the op amp maintains its output voltage for a long time.

There are a number of difficulties inherent in this simple approach. Firstly, since the switch in figure 4 corresponds to a key contact of the keyboard, the leakage resistance of the switch when open is the leakage resistance of 37 key contacts connected in parallel, which can be quite low, especially in a humid environment. This could be overcome by increasing the value of the capacitor so that it discharges more slowly, but it would then take much longer to charge from the keyboard divider chain, which would result in unwanted 'glissando' effects.

The solution is to use a double sample-and-hold circuit, as shown in figure 5. The pre S and H circuit stores the output of the keyboard on a small capacitor C1, the output being buffered by a source follower FET T1. Before the voltage on C1 can decay due to the key contact leakage the voltage at the source of T1 is transferred to a larger capacitor C2 by an electronic switch T2. The 'off' resistance of this switch is much higher than that of the keyboard, and T3 has a high input resistance, so C2 can hold its charge for quite a long time. T2 is switched by a gating pulse controlled by the second contact set of the keyboard. The cathode of D1 is normally at -14 V and T2 is thus cut off. When a key is depressed the gate pulse takes the cathode of D1 up to +14 V and T2 turns on.

Portamento control

When playing up and down a scale the control voltage from the source of T3 would normally consist of a series of discrete steps, as shown in figure 6a. This would give rise to equally discrete changes of pitch, the minimum change in pitch being one semitone interval of the tempered scale, as with any other keyboard instrument. However, many instruments are characterised by the ability to make continuous (smooth) changes of pitch, one example being the trombone with its slide. This style of playing is known as 'portamento'.

The circuit of a portamento stage is given in figure 7. It consists simply of a source follower FET, preceded by an

RC network that integrates the stepwise output of T3 to give a much smoother change as shown in figure 6b. P1 controls the 'smoothness' of the change. Note that, due to the FET tolerances, the source resistors R2, R4 and R6 must be selected on test, and this will be described in chapter 3.

Overall tuning, frequency modulation and offset balance

FETs connected as source followers differ in two essential respects from ideal voltage followers. Firstly, between gate and source there is always the gate-source voltage of the FET, which means that the source is always at a higher voltage than the gate. This appears as an undesirable positive offset voltage at the source of the FET, and since, in this circuit, three FETs are connected in cascade these offset voltages are additive. Secondly, the gain of a source follower is slightly less than unity, which means that a 1 V change on the gate does not produce a 1 V change at the source.

The offset voltage is compensated for in the circuit of figure 8. This comprises two IC op amps. IC3 is connected as an inverting summing amplifier, while IC4 is connected as a unity gain inverter to restore the correct sense of the control voltage. A negative voltage controlled by P4 may be summed with the control voltage input (KBV) to cancel out the positive offset voltage.

The gain losses in the sample and hold and portamento stages are compensated by increasing the current through the keyboard divider chain by means of P6 in figure 3 until a control characteristic of 1 octave/volt is obtained at the output of IC4.

Figure 4. Showing the principle of a sample-and-hold circuit.

Figure 5. The dual sample-and-hold circuit used in the Formant.

Figure 6. Showing the output waveforms of the keyboard interface when playing a scale (a) normally and (b) portamento.

Figure 7. Circuit of the portamento stage. P1 controls the 'smoothness' of the portamento.

Figure 8. Circuit of the offset compensation, octave tuning and frequency modulation stage.

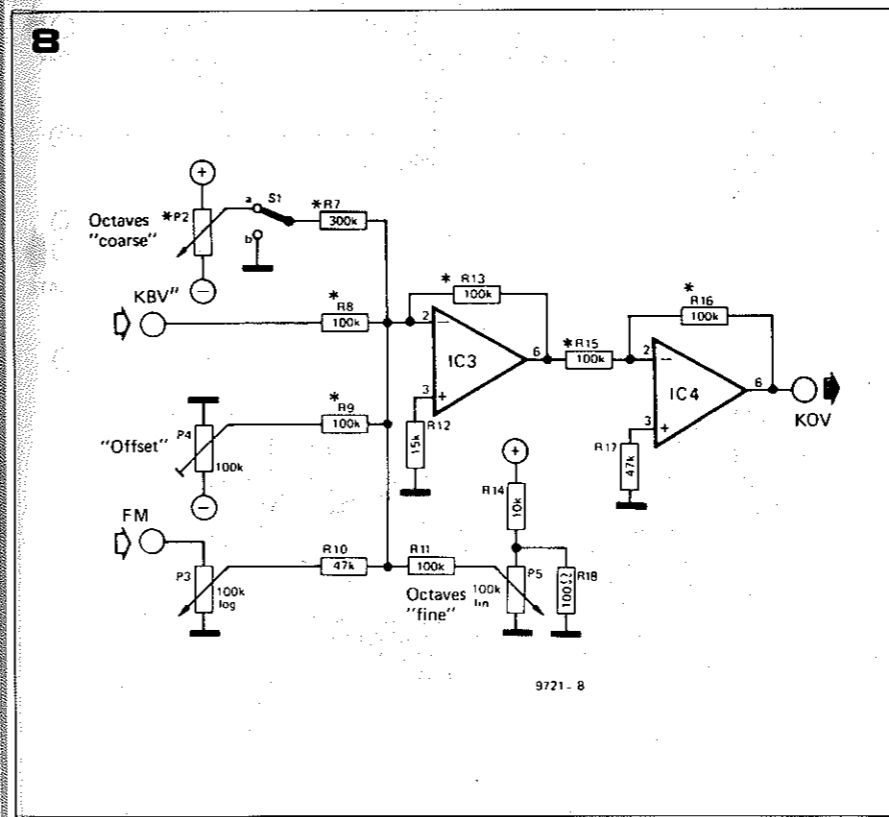
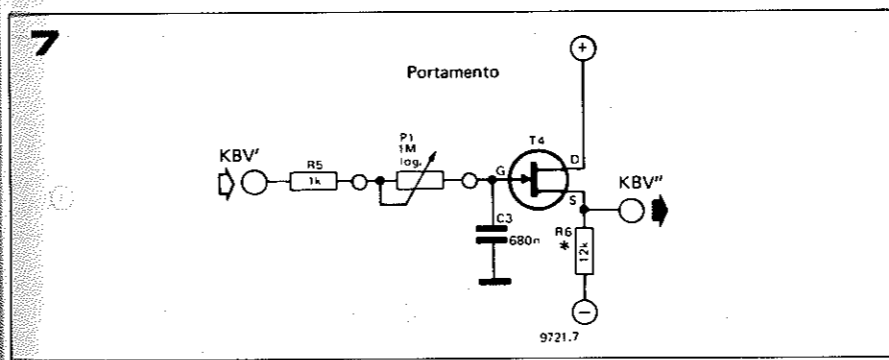
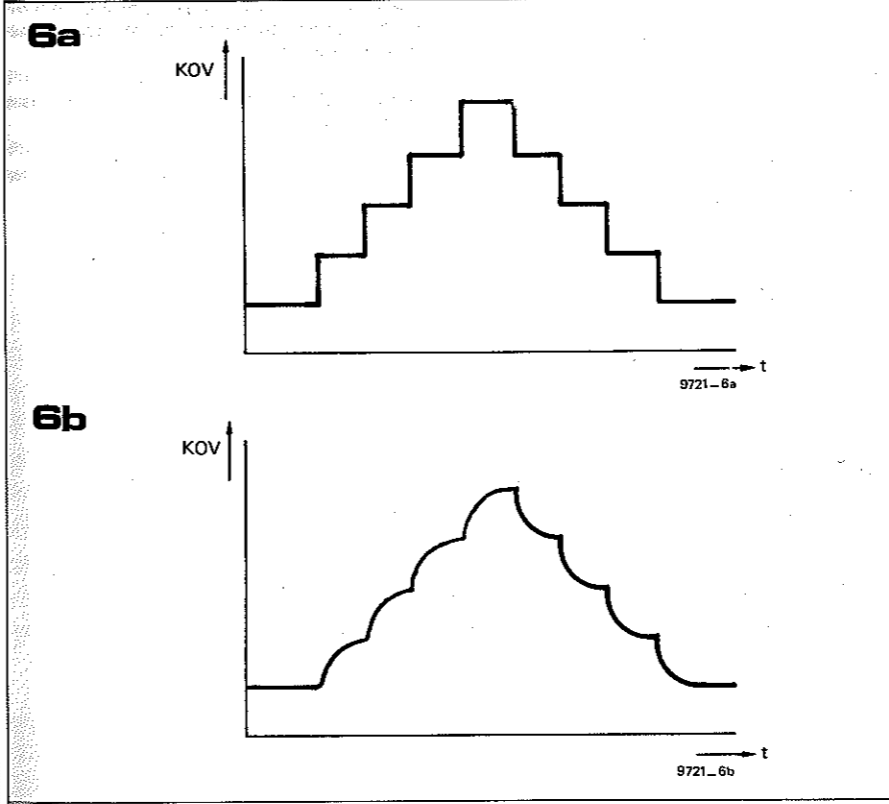
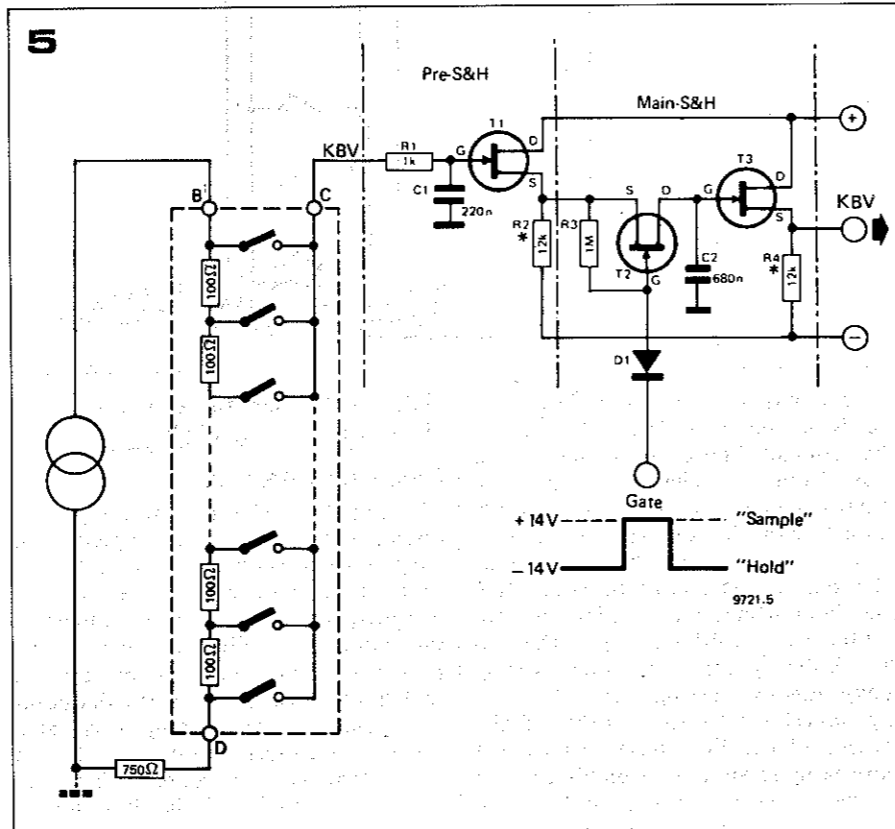
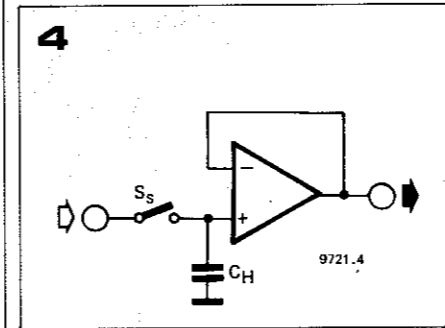

The circuit of figure 8 performs two additional functions. By adding a variable DC voltage to the control voltage the entire tuning range of the synthesiser may be shifted. P2 provides an adjustment of about 5 octaves, while P5 provides a fine adjustment of about ± one semitone, so that the synthesiser can easily be tuned to match other instruments.

A further input is provided for frequency modulation, for example to provide vibrato. The modulation level can be adjusted by means of P3, and with P3 fully clockwise the 'sensitivity' of this input is about 1 octave per 500 mV.

Gate circuit

Because of the action of the sample and hold circuit, once a key has been depressed the control voltage remains at the KOV output until another key is depressed. This would cause a note, once pressed, to sound indefinitely were it not for the envelope circuits that control the attack, sustain and decay of the notes.

Gate pulses to control the sample-and-hold circuit and to control the envelope shapers are derived from the second set of keyboard contacts. As shown in figure 9, these are all connected in parallel and fed with 4.7 V DC from IC1. When a key contact closes, the output of IC5 immediately goes to +4.7 V. C6 charges via P7 until its voltage exceeds the voltage on the inverting input of IC6 (IC6 functions as a comparator) when the output of IC6 will swing positive. When the key is released the output of IC5 will become zero and C6 will discharge rapidly through D2 so that the output of IC6 will swing negative.

The RC network P7/C6 provides an adjustable delay that compensates for a difference in closing time between the two sets of contacts. For example, should the gating contact close before the control voltage contact then the synthesiser would first sound a note determined by the residual voltage on C1 in figure 5. Then when the control voltage contact closed the correct note would sound. The delay network ensures that the gate pulse is delayed until after the new control voltage has been applied to C1. However, since C6 discharges rapidly through D2 the gate pulse ends immediately the key is released. C5 and R25 at the input to IC5 help to suppress noise due to contact bounce.

Construction

Figure 10 shows the complete circuit of the keyboard interface, while the printed circuit board and component layout are given in figure 11. The p.c. board for the divider chain is given in the following chapter.

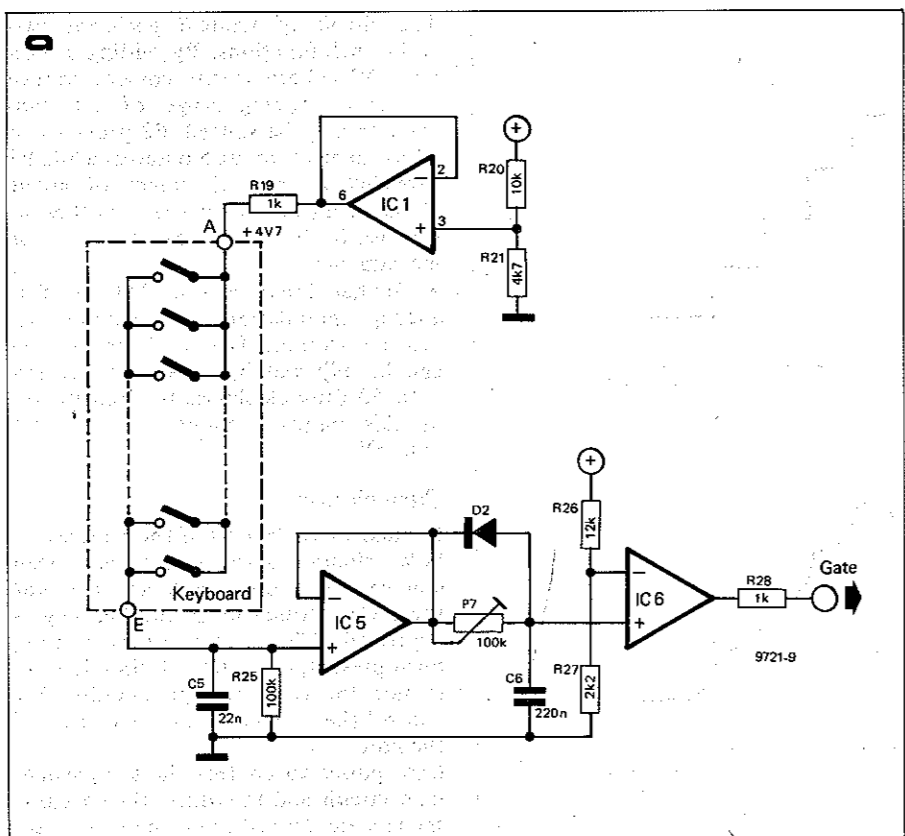

Figure 9. Circuit of the gate pulse generator, which is activated by the second contact set of the keyboard.

Figure 10. Complete circuit of the keyboard interface circuit.

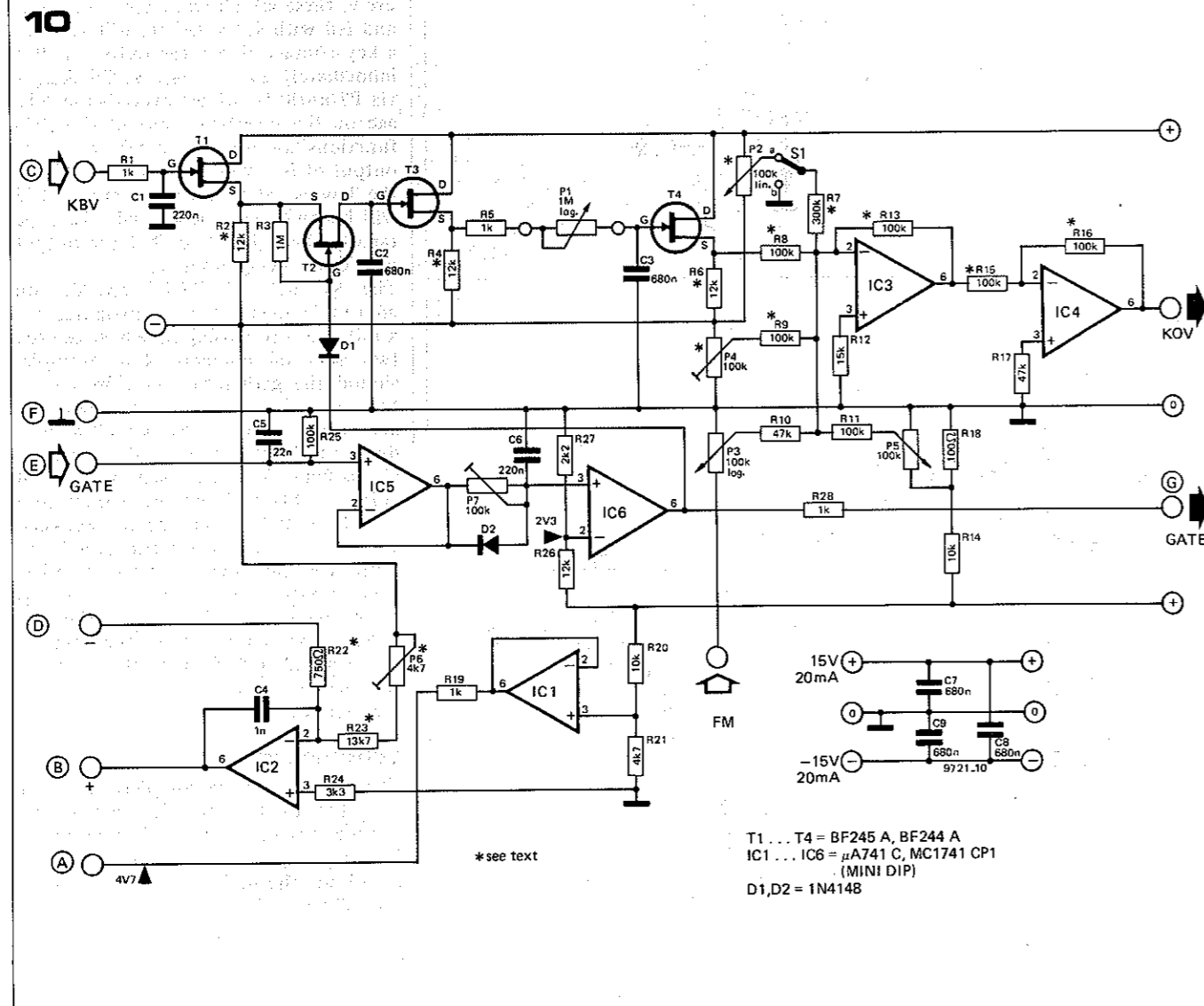
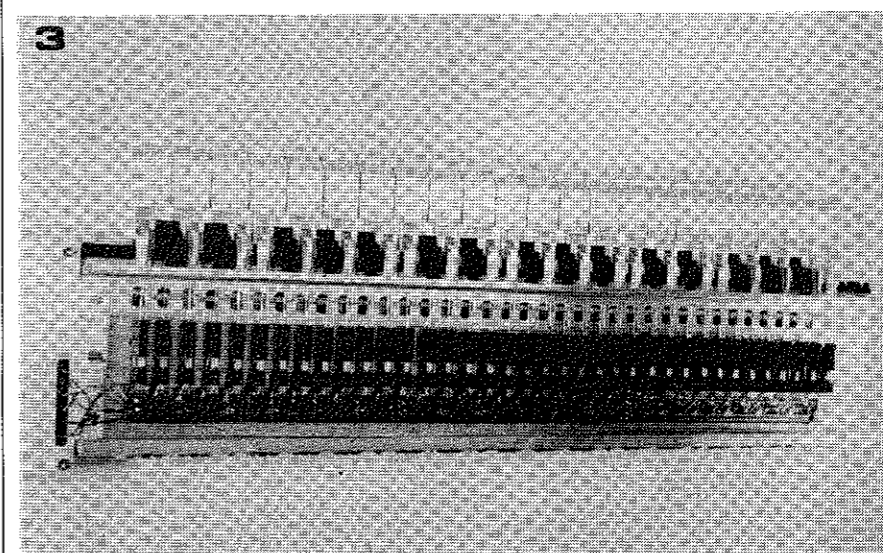
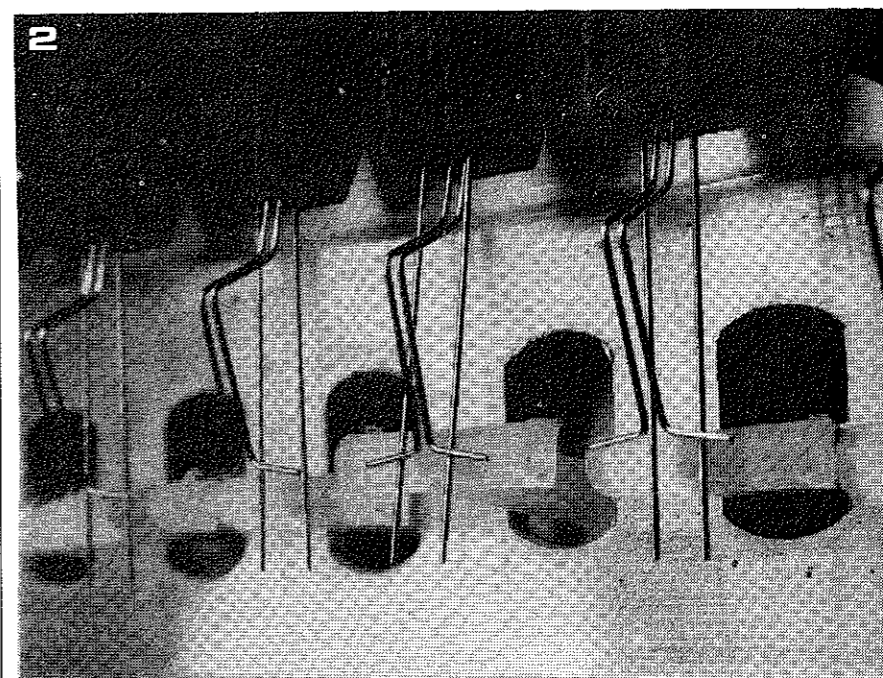
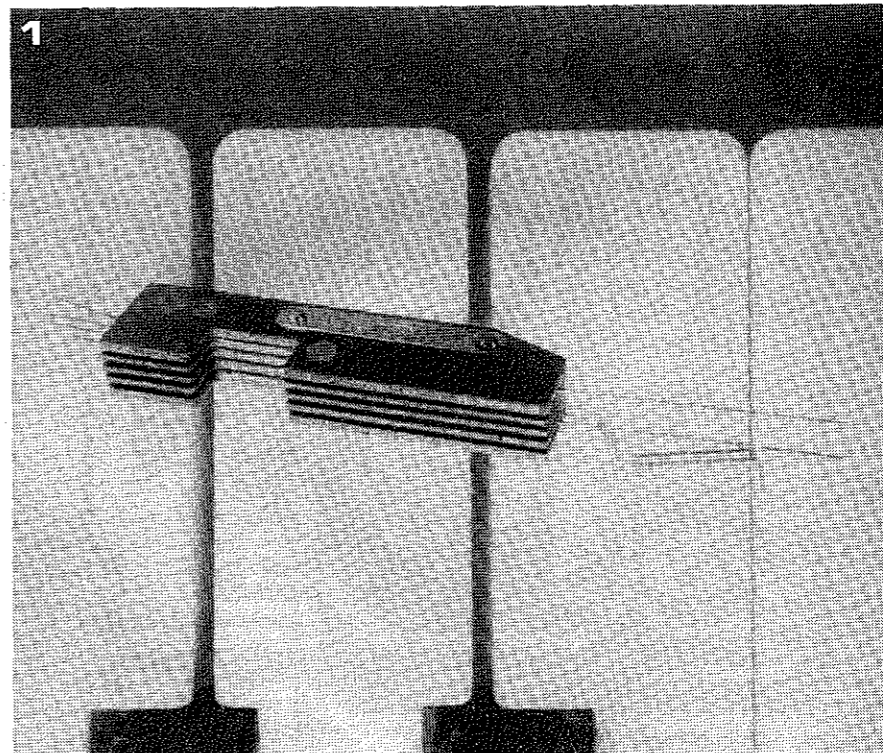

Photo 1. A Kimber-Allen contact block as used in the synthesiser.

Photo 2. Close-up of the contact blocks mounted on the underside of the keyboard.

Photo 3. View of the completed keyboard with the divider chain p.c. board in position.



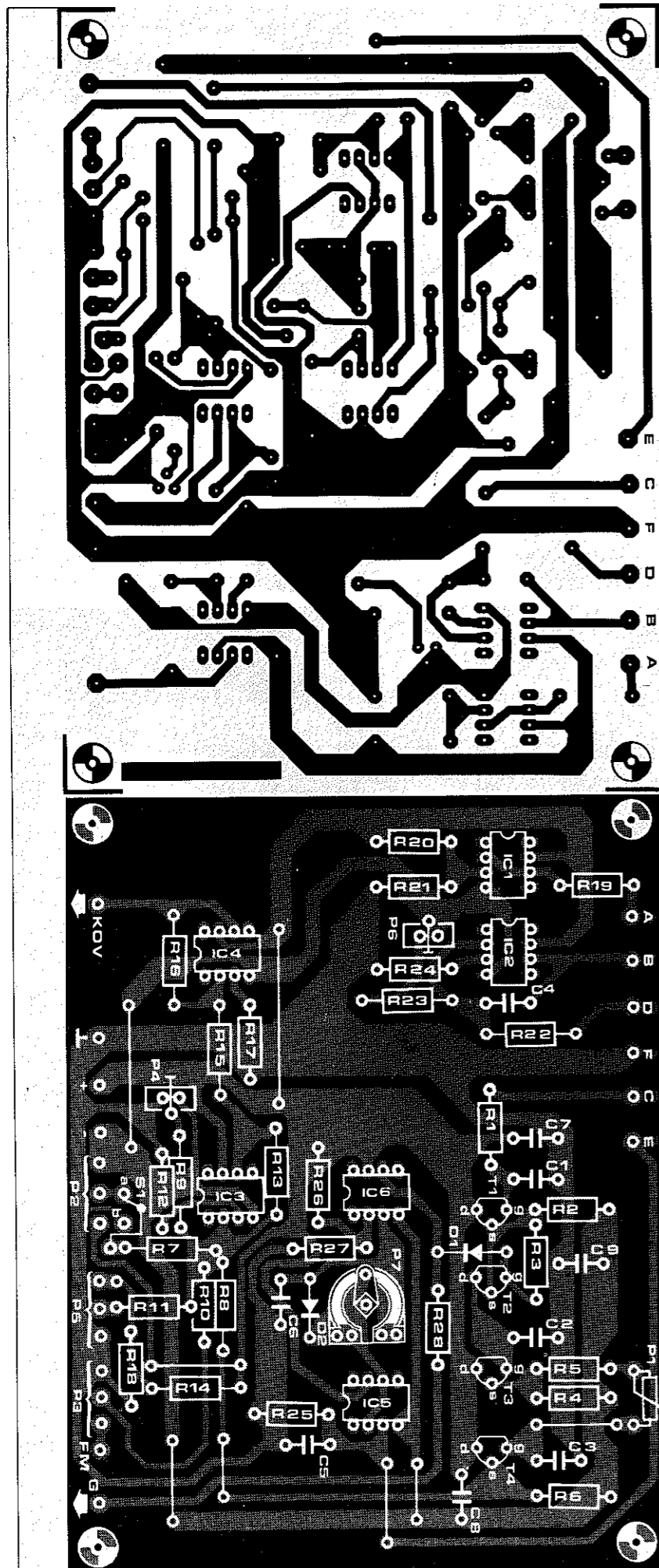

Figure 11. Printed circuit board and component layout for the keyboard interface circuit. (EPS 9721-1)

Parts list to figure 11.

Resistors:
 R1, R5, R19, R28 = 1 k
 R2, R4, R6 = 12 k (nominal value, see part 3)

R3 = 1 M
 R7 = 300 k (1% metal oxide)
 R8, R9, R13, R15, R16 = 100 k (1% metal oxide)
 R10, R17 = 47 k
 R11, R25 = 100 k
 R12 = 15 k
 R14, R20 = 10 k
 R18 = 100 Ω
 R21 = 4k7
 R22 = 750 Ω (1% metal oxide)
 R23 = 13k7 (1% metal oxide)
 R24 = 3k3
 R26 = 12 k
 R27 = 2k2

Presets:
 P4 = 100 k (Cermet)
 P6 = 4k7 (5 k, Cermet)
 P7 = 100 k

Potentiometers:
 P1 = 1 M log.
 P2 = 100 k lin. (Cermet)
 P3 = 100 k log.
 P5 = 100 k lin.

Capacitors:
 C1, C6 = 220 n
 C2, C3, C7, C8, C9 = 680 n Low leakage, low loss e.g. Siemens MKM,
 C4 = 1 n Wima FKS.
 C5 = 22 n

Semiconductors:
 T1 ... T4 = BF245A, BF244A (selected, see part 3)
 IC1 ... IC6 = μA 741 C,
 MC 1741CP1 (Mini-DIP)
 D1, D2 = 1N4148

Notes Except where otherwise specified resistors should be 5% carbon film. Metal oxide types should be 1% or better with temperature coefficient 100 ppm/°C max. Presets and pots, where specified, should be single turn cermet types. In some cases (e.g. for R23) 1% resistors are specified for their long-term and temperature stability, not for the exact value. If this value is difficult to obtain, a close approximation may be chosen, provided a 1% metal oxide resistor is used.

chapter 3

keyboard construction and power supply

In this chapter the p.c. board layout for the keyboard resistance divider is given, along with constructional details of the keyboard case and the test procedure for the keyboard interface assembly. The description of the voltage-controlled module unit is then commenced, starting with the power supply and details of the module case.

Wiring to the keyboard contacts is largely eliminated by mounting the keyboard divider chain on p.c. boards directly behind the keyboard contacts, so that the 'tails' of the contacts can be soldered direct to the p.c. board. The wiring diagram of the keyboard divider boards is given in figure 1.

The p.c. board and component layout are given in figure 2. Each p.c. board covers one octave of the keyboard, so three p.c. boards are required. They are linked by butting together the ends and wiring across from one board to the next, terminal A to terminal A', B to B' and so on.

At the left-hand end of the keyboard points A to E are joined to the corresponding points on the interface p.c. board by short wire links. Since each keyboard divider p.c.b. has connections for only twelve sets of key contacts the extreme right-hand set of contacts (note 37) must be wired to the end of the p.c.b. as shown in figure 3. Note also the wire link between points B' and D'.

In order that the p.c. boards may be mounted directly behind the key contacts by glueing, the resistors and connections to the p.c.b.'s are on the

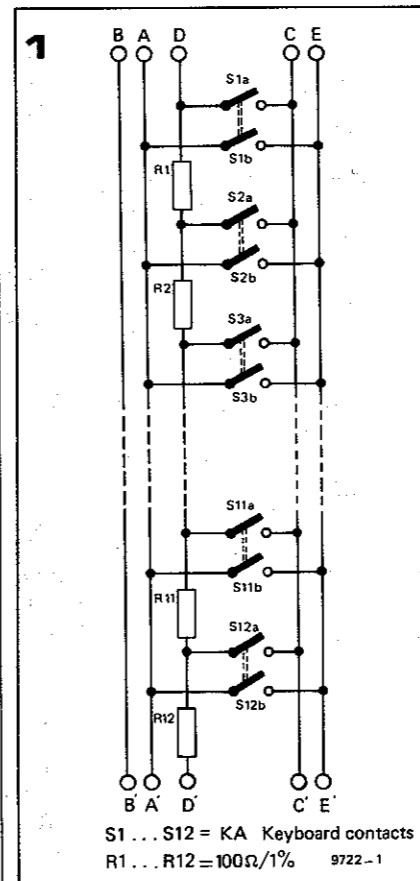

Figure 1. Circuit diagram of one keyboard divider p.c.b.

Figure 2. Printed circuit board and component layout for the keyboard (EPS 9721-4).

Table 1. Selection table for FET source resistors.

U _s (V)	R _s (k Ω)
0.2	22
0.25	18
0.3 ... 0.4	15
0.4 ... 0.5	12
0.6 ... 0.8	10
0.9 ... 1.1	8.2
1.2 ... 1.6	6.8

At the same time the gate leakage of each transistor should be checked to ensure that it is within acceptable limits. This is done by removing the grounding link across C_G (330 p). This capacitor will now charge through the gate leakage of the FET, and the source voltage will rise. The rate of change of voltage should be slower than one volt per second. Any FET which cannot meet this criterion should be rejected. This test should also be applied to T2, and when the tests are complete each FET, together with its selected source resistor, can be soldered into the circuit. Due to the possibility of leakage around the sample and hold area of the circuit (T1 to T3) great care should be taken to ensure that the back of the board is scrupulously clean, with no blobs of soldering flux or greasy thumbprints. After testing, the back of the board may be sprayed with insu-

Parts list to figure 2

Resistors:
 R1 ... R12 = 100 Ω/1%

Miscellaneous:
 S1 ... S12 = KA keyboard contacts

Note that one board is required for each octave. For a three-octave synthesiser, for instance, three boards and 36 resistors are required. For further details see text, figures 1 and 3 and photos 1 and 2

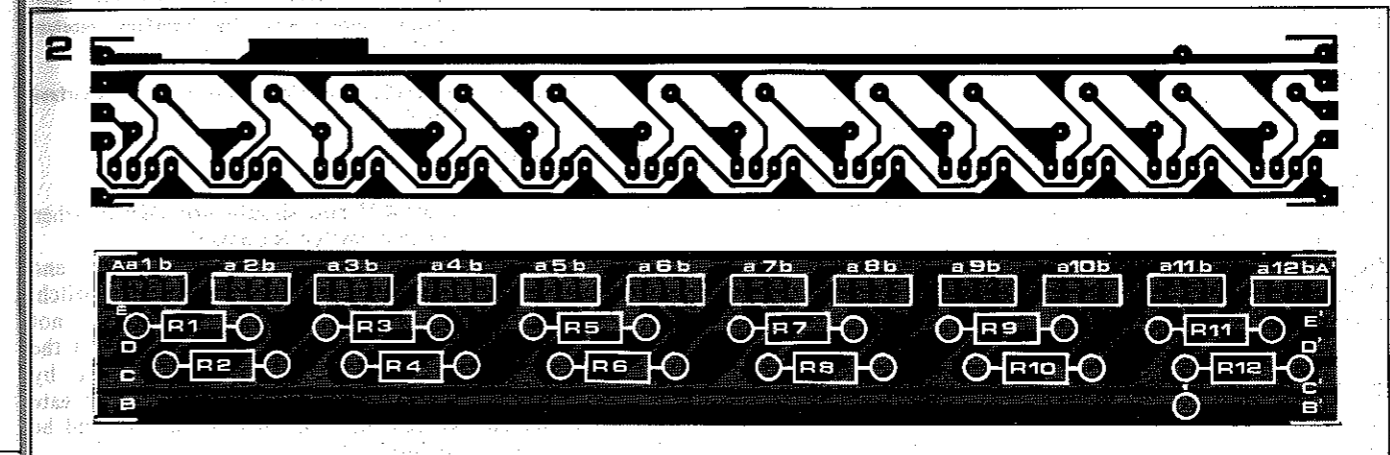

lating varnish.

Although the BF244 or BF245 is specified for T1 to T4, since practically all specimens of this device will function in the circuit, it is possible to use the cheaper and more popular 2N3819 for T2. It should be noted that the board is laid out for the pinning of the BF245. The pinning of the BF244 and most 2N3819's is different, as shown in figure 4b.

Interface receiver

In the early design stages the KOV and GATE outputs from the interface board were fed direct into the voltage controlled modules. However, it was soon discovered that the input currents taken by these modules caused significant voltage drops along the connecting cable between keyboard and module unit, especially if this was long. In particular, earth return currents along the common earth wire shared by the KOV and GATE outputs caused modulation of the keyboard voltage by the gate pulse. This problem was overcome by providing high impedance buffer stages at the receiving end of the connecting cable. The circuit for this 'interface receiver' is shown in figure 5. It consists simply of a 741 connected as a voltage follower for the KOV input, and a similar voltage follower with an input delay circuit for the GATE input. The output of this circuit also drives an LED to indicate when a gate pulse is present. A printed circuit board and component layout for the interface receiver are given in figure 6. The two outputs are taken from single screw terminal blocks cut from a 'chocolate block' type of mains connector. This is so that connections to extra voltage controlled modules can be added if and when the system is extended.

Testing of the keyboard interface assembly

Once the keyboard interface (see chapter 2, figures 10 and 11) and interface receiver boards are complete they can be tested, provided a ± 15 V supply is available, otherwise the testing must wait until the synthesiser power supply has been built. The final adjustment is not carried out until the keyboard assembly is mounted in its case, but these preliminary tests will show up any faults in the circuits and save a lot of frustration at a later stage. The test procedure is as follows:

1. Current consumption

Connect positive and negative supplies to the keyboard interface (chapter 2, figure 10) and measure the current flow in both the positive and negative supply leads. This should be between 18 and 25 mA.

2. Keyboard current source

a) Connect a multimeter between points B (positive) and D (negative) and

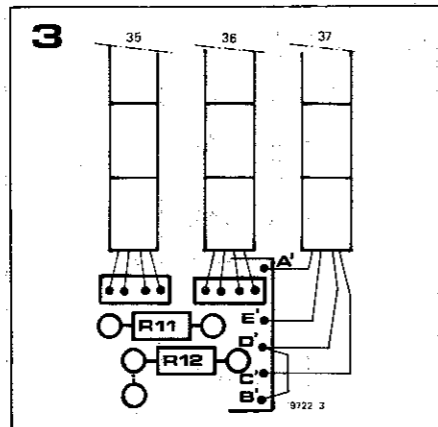

adjustable between 0.8 and 1 mA by means of P6.

b) Check the virtual earth point, pin 2 of IC2. The voltage between this point and the 0 V rail should be less than 5 mV, with a 1 k resistor connected between points B and D.

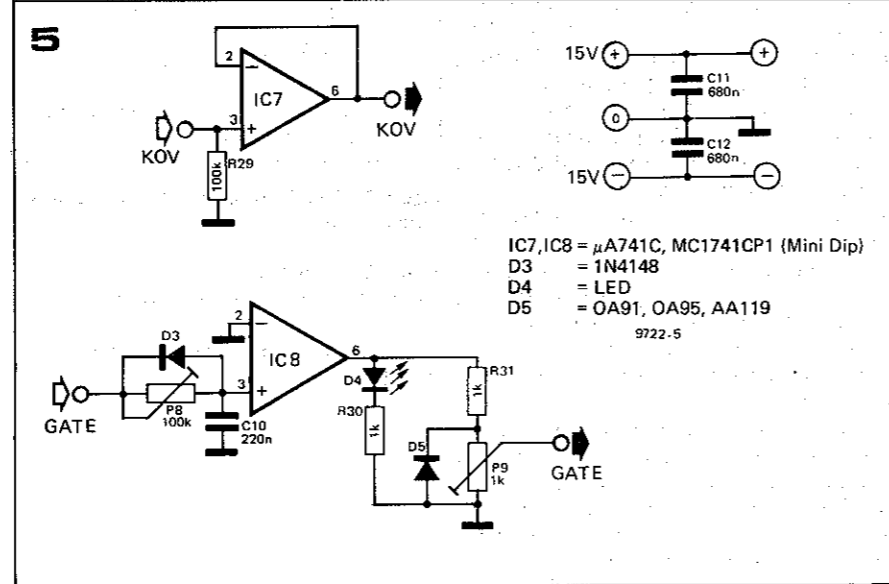
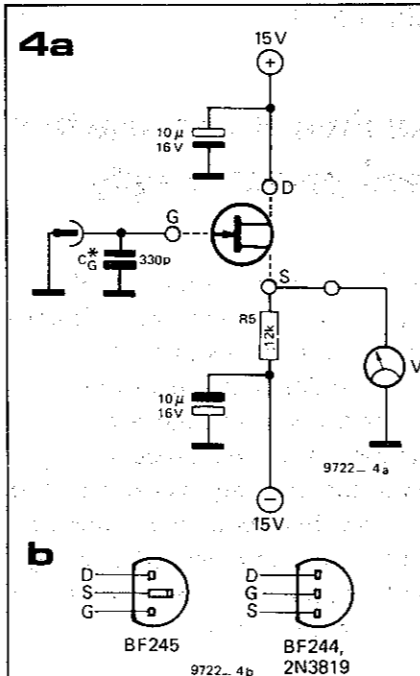

Figure 3. Showing the wiring to the 37th key contact block.

Figure 4. Test circuit for FET's and pinouts of BF244, BF245 and 2N3819.

Figure 5. Circuit of the interface receiver.

Figure 6. Printed circuit board and component layout for the interface receiver (EPS 9721-2).

Figure 7. Mounting plate for the interface board.

monitor the current. This should be adjustable between 0.8 and 1 mA by means of P6.

b) Check the virtual earth point, pin 2 of IC2. The voltage between this point and the 0 V rail should be less than 5 mV, with a 1 k resistor connected between points B and D.

3. Gate circuit

Connect point E on the interface board to point A via a switch and measure the voltage at point G with respect to 0 V. It should be -12 to -15 V with the switch open and +12 to +15 V with the switch closed.

4. Sample and hold

a) Retain the switch from the previous test. Connect point C to an SPDT switch so that this point can be switched between point A and ground. With point C grounded, the gate switch closed and P1 set to minimum resistance the source voltage of T4 must be less

than 4 V and should not change when the gate switch is opened.

b) Leave the gate switch open and ground point C using the SPDT switch. The source voltage of T4 must not change. Close the gate switch and the source voltage should now rise by between 3.6 and 4.6 V. Open the gate switch and this new voltage should be maintained.

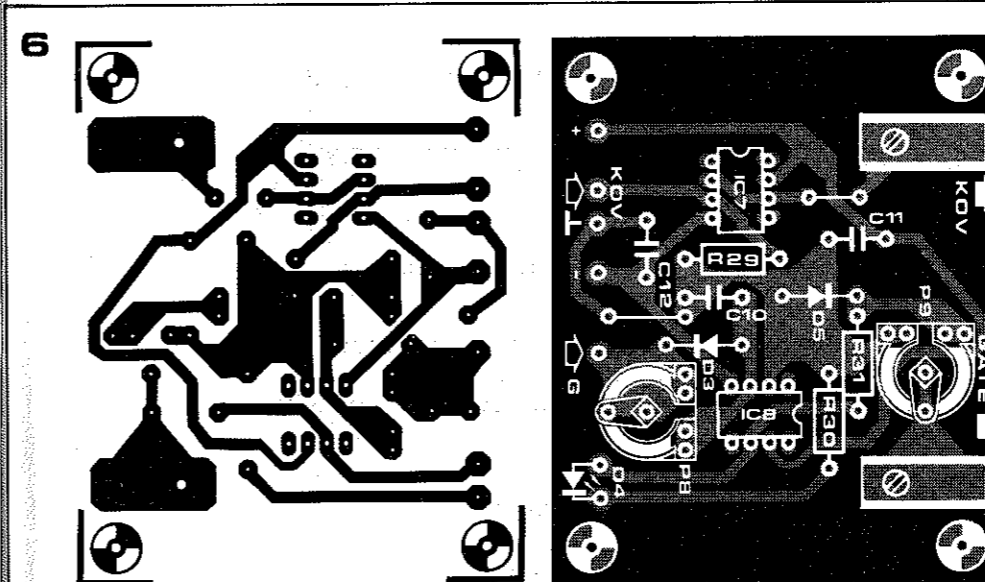

a) Set P1 to maximum resistance, changeover switch to ground point C and close the gate switch. The source voltage of T4 should now drop to its original value over two to three seconds.

b. Summing amplifier

a) Offset adjustment. Maintain the same switch positions as in test 4c. Using S1, switch P2 out of circuit and turn sliders of P3 and P5 to ground. Use P4 to set the KOV output to zero volts.

b) Coarse tuning. Switch P2 into circuit using S1 and turn P2 fully clockwise and then anticlockwise, when the KOV output should be +5 V and -5 V respectively.

c) Fine tuning. Switch P2 out of circuit

and turn P5 fully clockwise, when the KOV output should be about 150 mV. d) FM. Turn P5 fully anticlockwise. Link point FM to point A on the board. Using P3 it should be possible to vary the KOV output between zero volts and about 10 V.

6. Interface receiver

Interconnect the interface and interface receiver boards (connections GATE, KOV, +15 V, -15 V and ground). Repeat tests 3 and 5b, but monitor the KOV and GATE outputs of the interface receiver. With the gate switch closed the indicator LED should glow. Finally, with the gate switch closed, use P9 to set the gate output voltage of the

interface receiver to +5 V.

Keyboard unit assembly

Once the interface board has been tested, it and the keyboard can be joined to make an integrated keyboard unit.

This is accomplished by first making an aluminium mounting plate for the interface board, as shown in figure 7. The 'tongue' of this plate fits along the underside of the keyboard chassis (at the left-hand end) and is secured by three 4 mm nuts, bolts and lockwashers. A solder tag beneath one of the nuts provides an earthing point for the keyboard. Note that the larger diameter hole in the tongue is not used yet; it will be required for mounting the keyboard in its case.

The next step is to mount the keyboard divider boards. As illustrated in photo 1, these boards should be interlinked in such a way that the ends of the boards actually touch at the junction, as otherwise the spacing of the contacts on the board with respect to the switch contact blocks will not be accurate. As described in chapter 2 (and illustrated in figure 2b), the contact blocks should be glued or bolted to a 3 mm thick plastic spacer (F). The keyboard divider boards can now also be mounted on this spacer, using either epoxy adhesive or double-sided self-adhesive tape ('Servotape', 'Tesatape' or similar). Note that the front of the divider boards should touch the contact blocks, as otherwise the wires from the blocks may be too short. The interface board can now be mounted on top of its mounting plate using 4 mm nuts, bolts and spacers, and connections between the keyboard p.c.b.'s and the interface board are made by short wire links which pass through the rectangular slot in the mounting plate. The earthing point for the keyboard chassis is connected to point 'F' on the interface board. The complete assembly can be seen in photos 2 and 3.

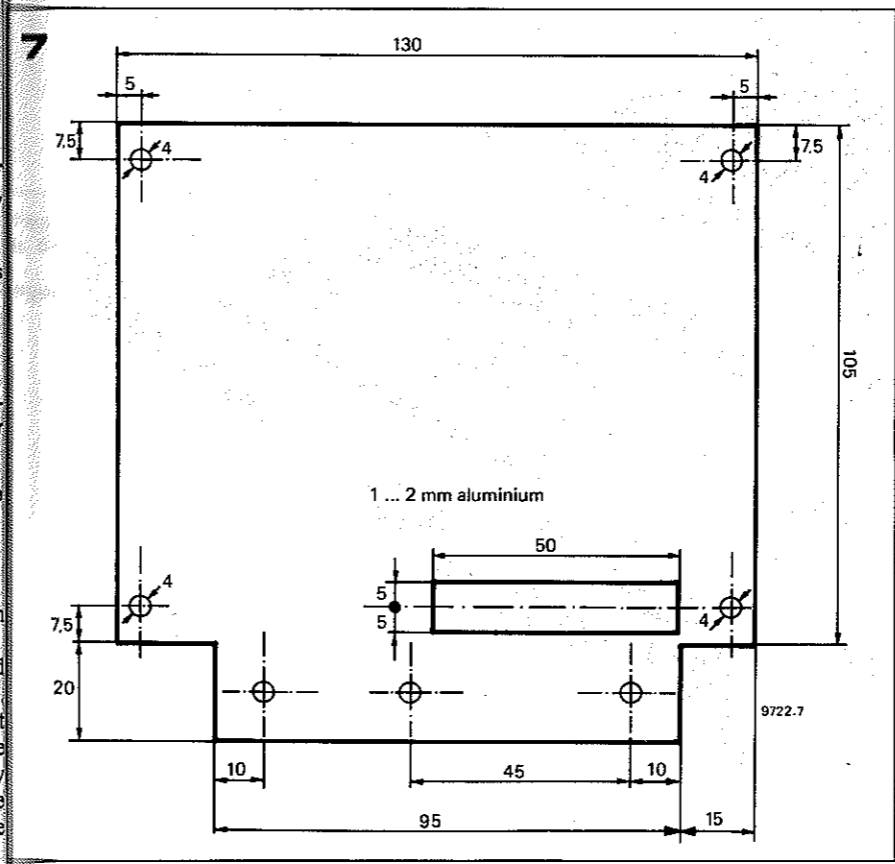

Parts List to figure 6

Resistors:
R29 = 100 k
R30, R31 = 1 k

Presets:
P8 = 100 k
P9 = 1 k

Capacitors:
C10 = 220 n
C11, C12 = 680 n

Semiconductors:
IC7, IC8 = µA741C, MC1741CP1 (mini DIP)
D3 = 1N4148
D4 = LED e.g. TIL209
D5 = OA91, OA95, AA119

8a

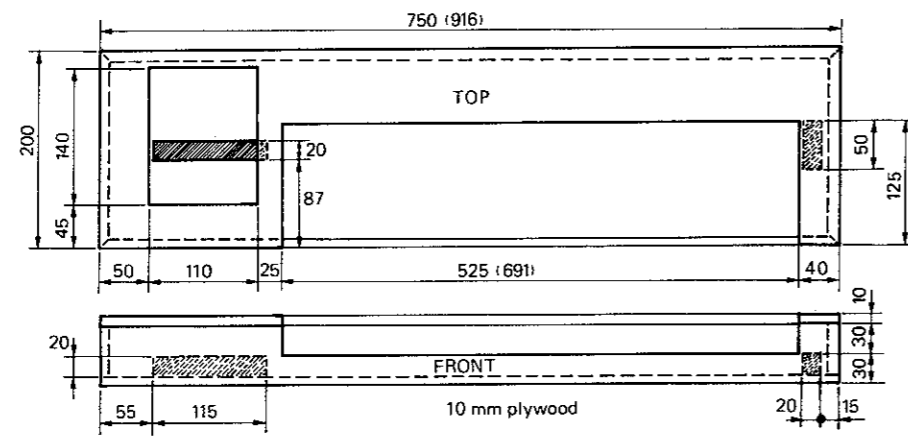

Notes: 1) All dimensions in mm
 2) Normal dimensions valid for 3-octave Keyboard
 3) Dimensions shown in brackets valid for 4-octave Keyboard

9722 8

b

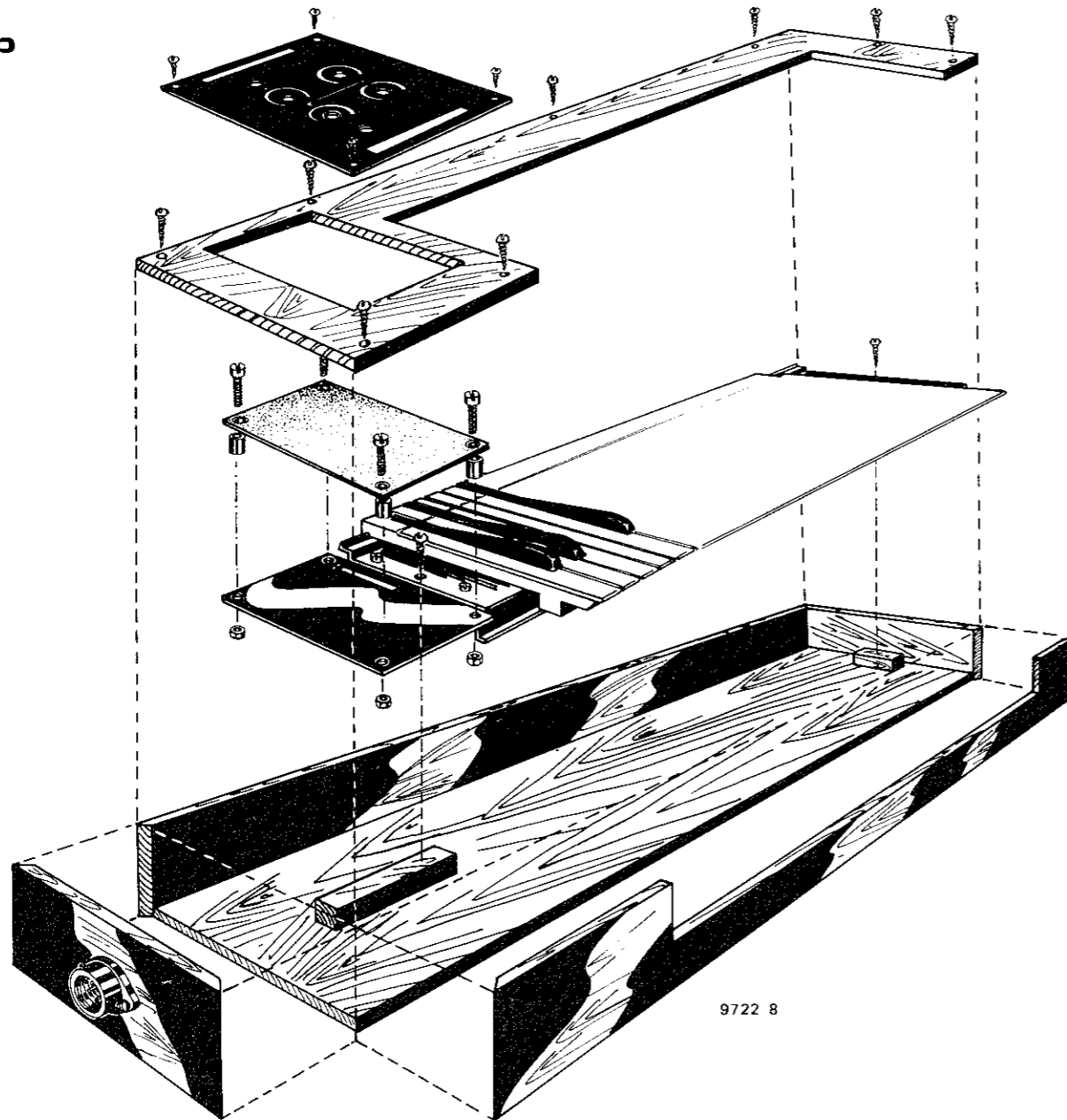

9722 8

9

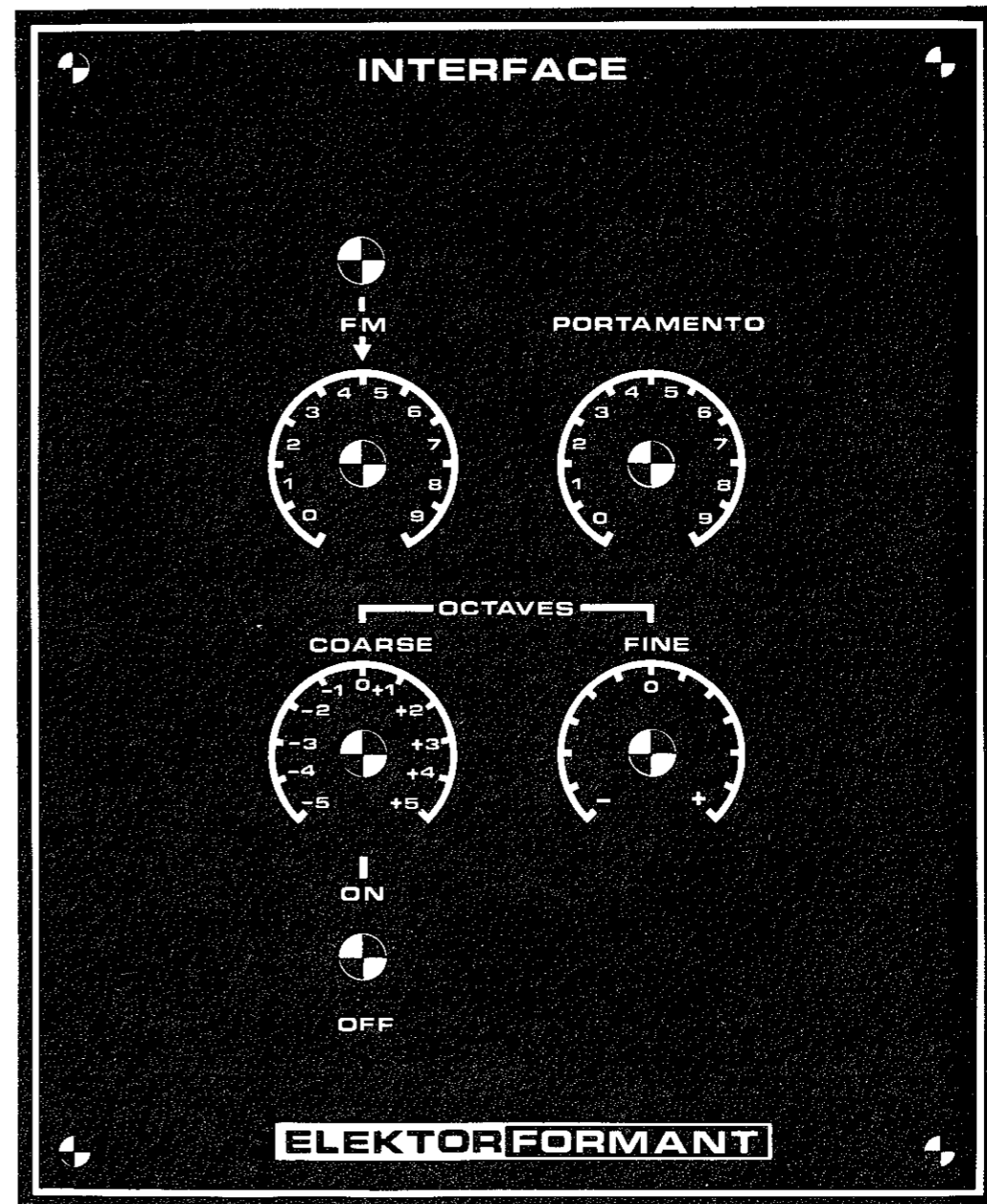

Figure 8. a: Dimensions of the keyboard case.
 b: Exploded view of the keyboard case.

Figure 9. Interface board control panel.

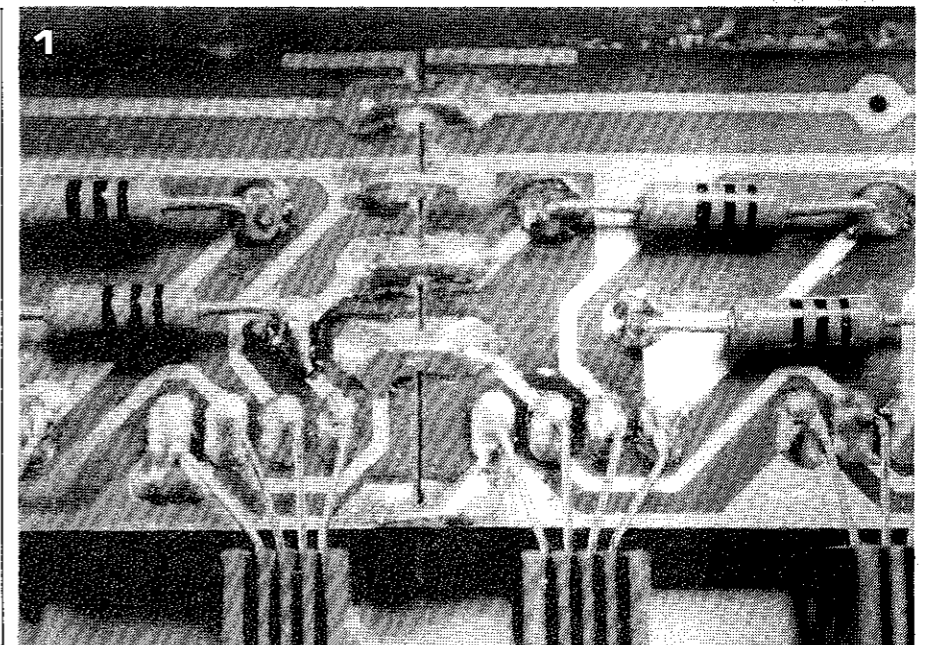
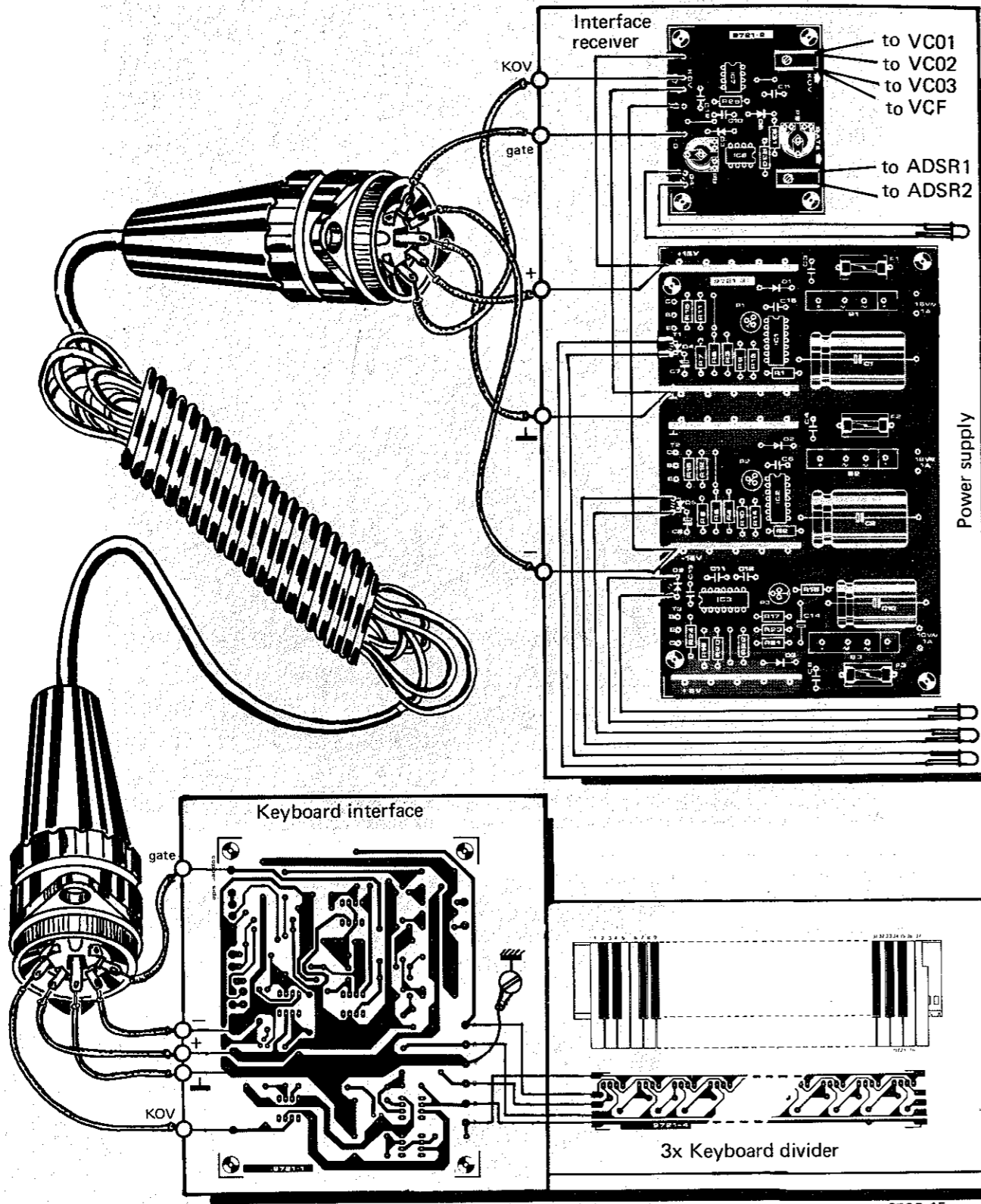

Photo 1. Showing the wiring of the key contacts to the keyboard divider p.c.b.

10



9722 15

11

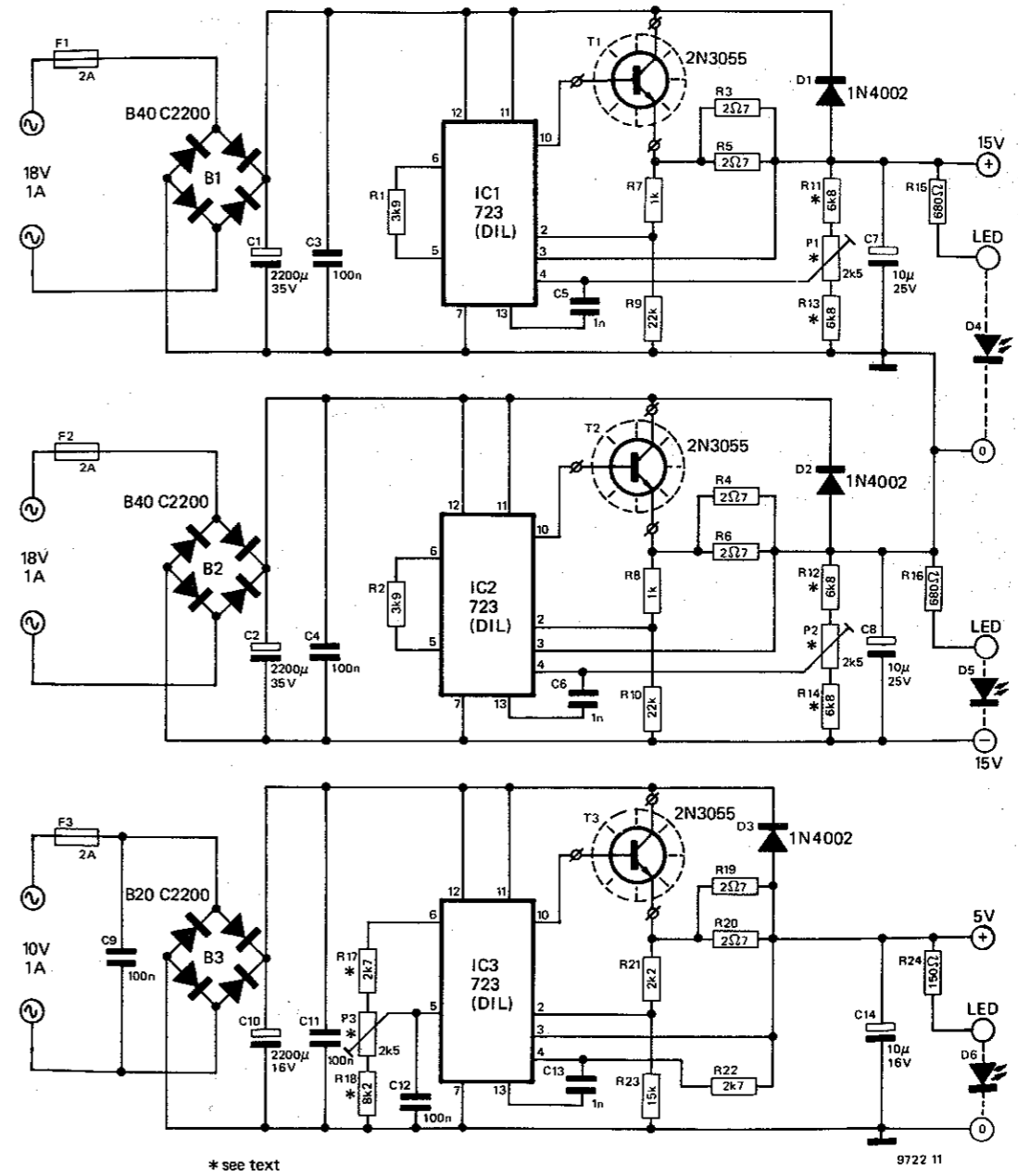

* see text

9722 11

Figure 10. Showing the wiring between the keyboard unit, interface receiver and power supply.

Figure 11. Circuit of the Formant power supply.

Photo 2. Detail of the wiring between the keyboard divider and the interface board.

Although the keyboard unit is now a single assembly it still requires a case to house it, and the dimensions of a suitable case are given in figure 8a. The materials should be chosen to suit the type of use (or abuse) to which the synthesiser will be subjected, and the choice is left to the individual constructor. However, the dimensions given in figure 8a are based on some assumptions,

and if other materials are used the dimensions may have to be adjusted accordingly. The assumptions are that the baseboard is made of 10 mm plywood; that the top panel is also made of fairly thick plywood (10...15 mm) so as to leave room for the potentiometers above the interface board; that the side panels are made of plywood no thicker than 15 mm.

Particular note should be taken of the two wooden spacers glued to the bottom. These are required for mounting the finished keyboard assembly in the case.

Figure 8b is an 'exploded view' of the complete assembly, illustrating several of the points mentioned above. For screening purposes the inside of the case should be completely lined with thin aluminium or copper sheet or foil, which must be connected to ground. A front panel layout for the interface controls is given in figure 9. This mounts directly over the interface board and

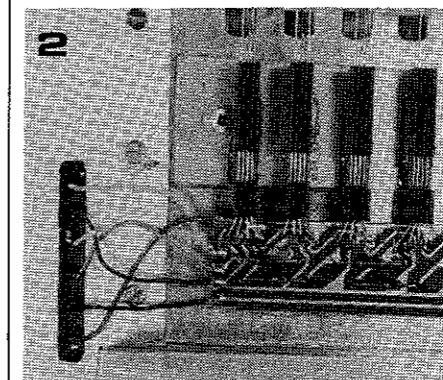

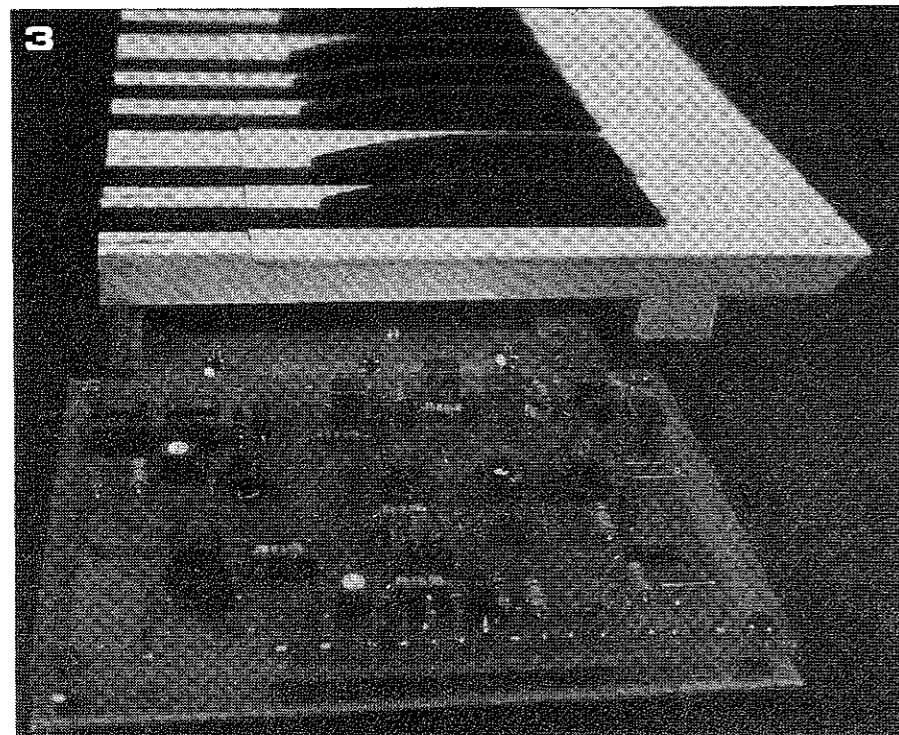

is secured to the keyboard case by four chromium-plated wood screws. Potentiometers P1, P2, P3 and P5 (portamento, FM, coarse and fine tuning) are mounted on the front panel, together with S1 and the FM input socket, which is a 4.5 mm jack. Connections between the front panel and the interface board should be made sufficiently long to enable the front panel to be removed without difficulty. If desired one edge of the front panel may be hinged for easy access to the interface board. The output and supply connections to the interface board are made by means of 5-pin DIN connectors, and a hole for the DIN socket should be cut in the side of the keyboard case adjacent to the interface board. The DIN-connectors should be high quality locking types, as the cheap

Photo 3. Showing the mounting of the interface board.

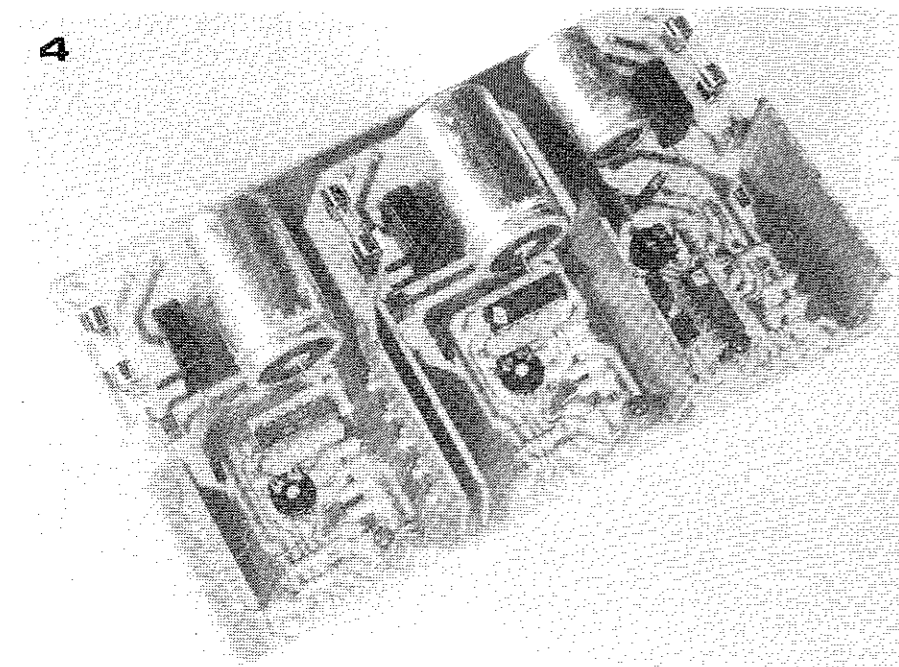

Photo 4. The completed power supply board.

plastic variety will quickly fail after repeated connecting and disconnecting. Connections from the interface board to the DIN socket are shown in figure 10.

Power Supply

For final adjustment of the keyboard unit it is necessary to use the synthesiser's own power supply to ensure accurate setting of the volts/octave characteristic of the keyboard. For this reason the power supply circuit is now described.

Three output voltages are required for the synthesiser: +15 V, -15 V and +5 V. These must all be stable and easily adjustable, and for this reason all three supplies are based on the tried and trusted 723 precision voltage regulator IC. The circuit of the power supply unit is given in figure 11.

It will be noted that all three circuits are positive regulator circuits with an external power transistor to increase the output current. The -15 V supply is obtained simply by linking the positive output of this circuit to ground. This does have the slight disadvantage that separate transformer windings and rectifiers are required for each 15 V supply but it does mean that both the positive and negative supplies are of identical design.

Each supply is equipped with foldback current limiting, and can comfortably supply over 800 mA, which should be adequate for any possible extension of the synthesiser. When limiting occurs (at about 1.2 A) the output voltage will fall and the current will fold back to about 500 mA with a short-circuited output. Current limiting of any of the outputs is indicated by the extinction of the LED indicator connected across that output.

A printed circuit board and component layout for the power supply unit are given in figure 12, and it should be noted that the output connections T1, T2, T3 are different from those of T1 and T2, being arranged B-E-C instead of C-B-E. Good quality components should be used in the construction of the

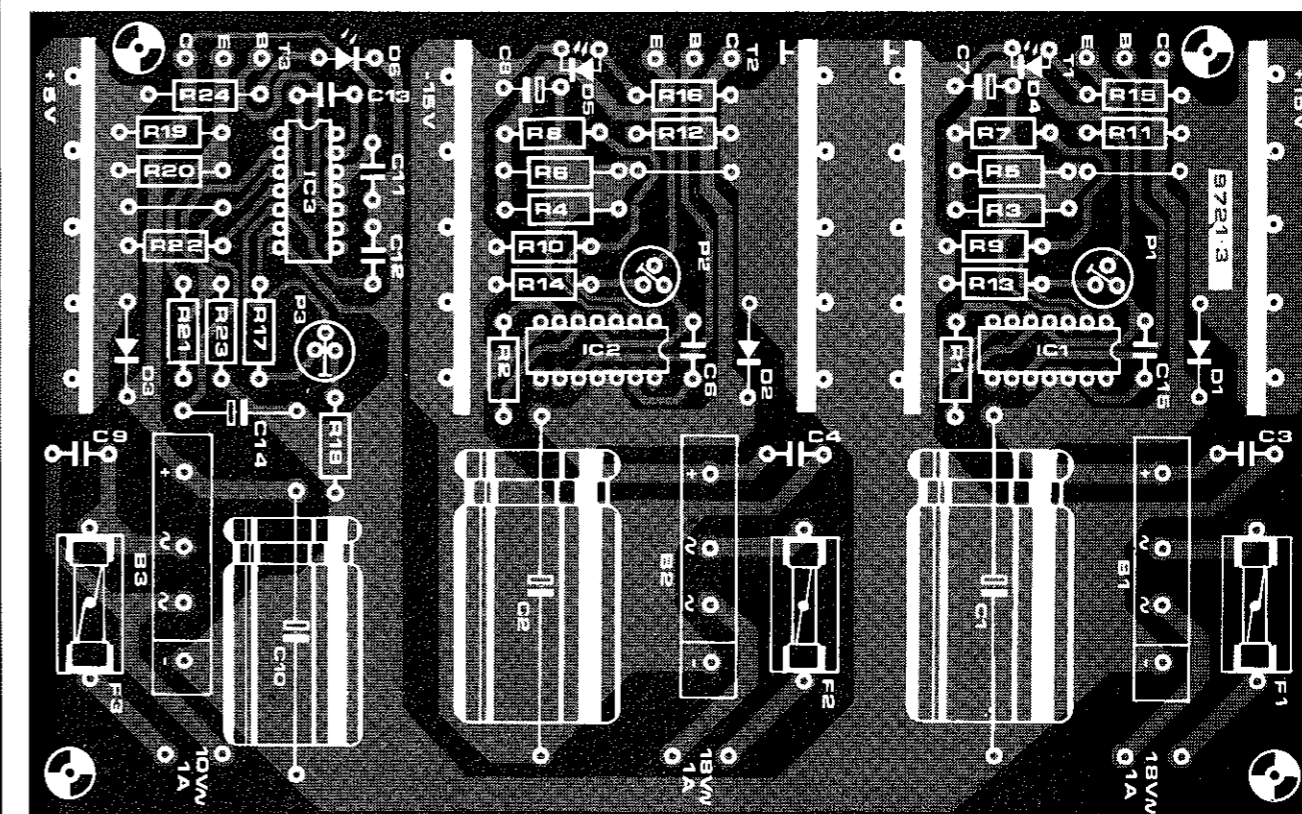
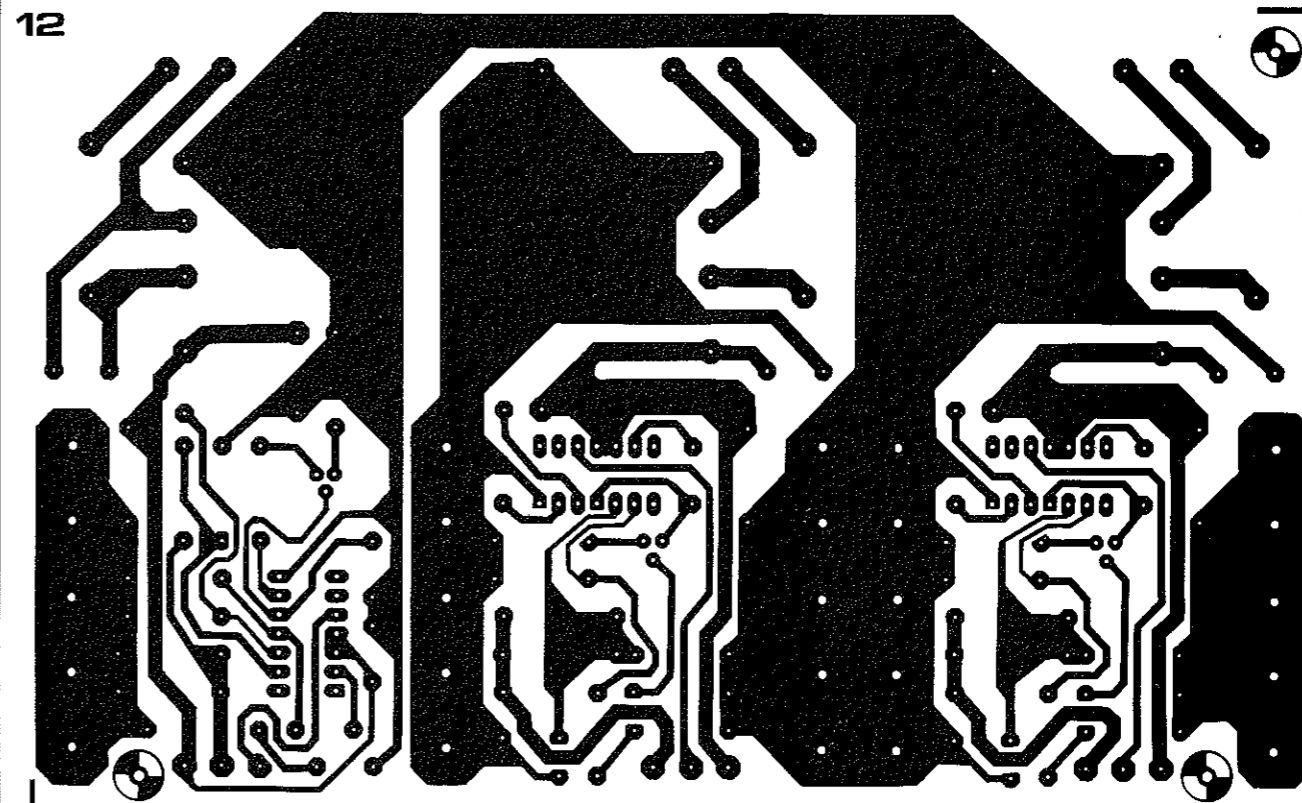

Parts List to figure 12

Resistors:

R1, R2 = 3k9
R3, R4, R5, R6, R19, R20 = 25Ω/0.5 W
R7, R8 = 1 k
R9, R10 = 22 k
R11, R12, R13, R14 = 6k8
(2% metal oxide)
R15, R16 = 680 Ω
R17 = 2k7 (2% metal oxide)
R18 = 8k2 (2% metal oxide)
R21 = 2k2
R22 = 2k7
R23 = 15 k
R24 = 150 Ω

Presets:

P1, P2, P3 = 2k5 miniature (7 mm) cermet

Capacitors:

C1, C2 = 2200 μ/35 V
C3, C4, C9, C11, C12 = 100 n
C5, C6, C13 = 1 n
C7, C8 = 10 μ/25 V tantalum
C10 = 2200 μ/16 V
C14 = 10 μ/16 V

Semiconductors:

D1, D2, D3 = 1N4002

D4, D5, D6 = LED (e.g. TIL 209)

T1, T2, T3 = 2N3055
IC1, IC2, IC3 = 723 (DIL)
B1, B2 = 40 V 2.2 A bridge rectifier B40/C2200
B3 = 20 V 2.2 A bridge rectifier B20/C2200

Miscellaneous:

F1, F2, F3 = 2 A slow blow fuse
Transformer(s) with 18 V, 18 V and 10 V secondaries at 1 A
3 Heatsinks approx 100 mm x 50 mm with 30 mm fins

Figure 12. Printed circuit board and component layout for the power supply (EP 9721-3).