

Ancillary Boards

4

Contents

Audio PSU and headphone amp.....	4.2
Peripheral connector board.....	4.3
Internal cabling.....	4.4

CMI-310

Audio PSU and Headphone amp

4.2

Block diagram.....	4.2.2
Introduction.....	4.2.3
Voltage regulator.....	4.2.3
Headphone amplifier.....	4.2.3
Rectification and filtering.....	4.2.3
Voltage regulator.....	4.2.4
Headphone amplifier.....	4.2.4
Circuit diagrams.....	4.2.5

Block Diagram

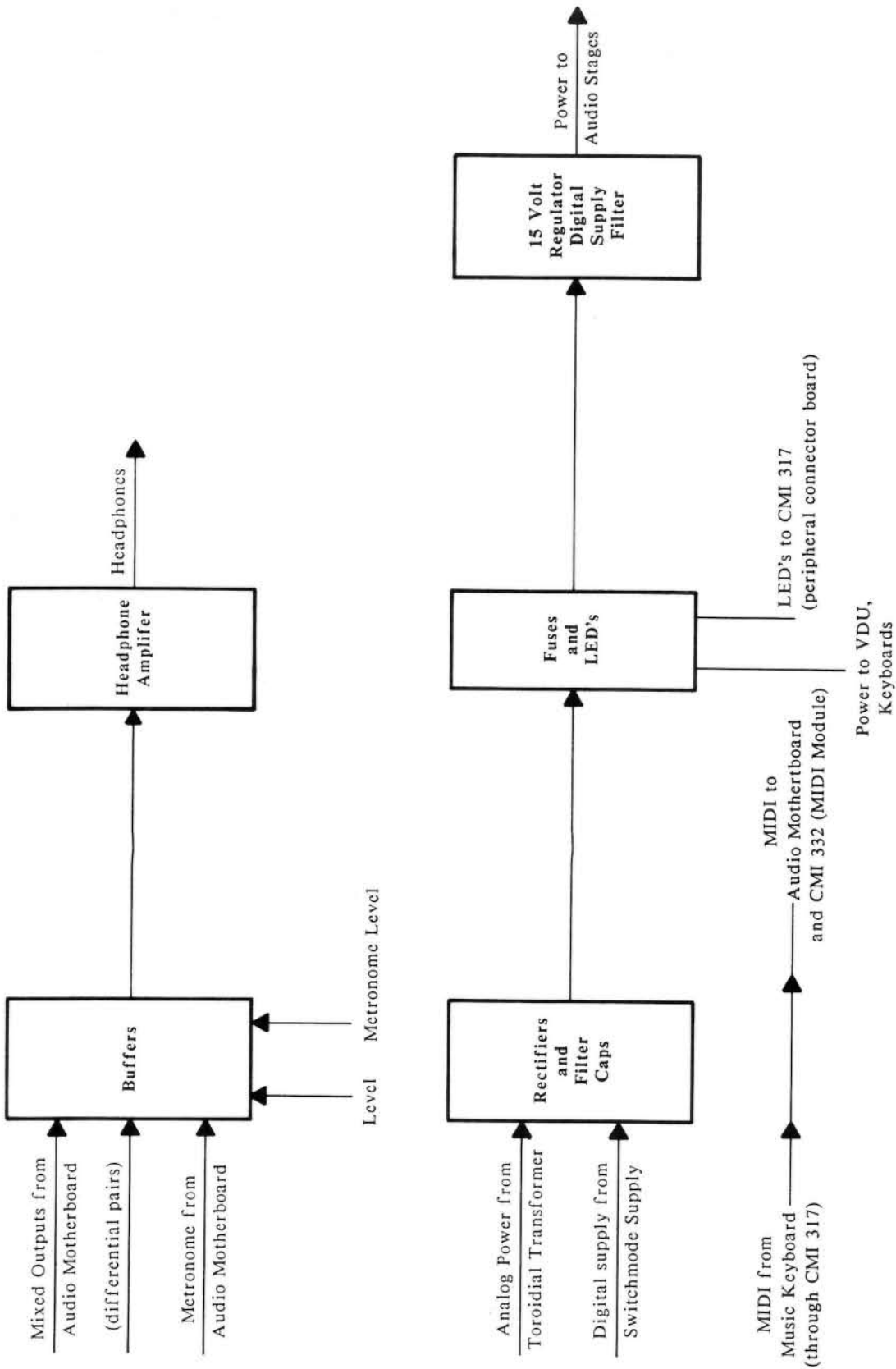

Terminology

APSU: Analog Power Supply Unit

AR: Audio Rack assembly

Introduction

The Analog Power Supply Unit (APSU) provides the rectified and filtered power to the VDU, Keyboards and Audio Rack components of the CMI. In addition it contains a tracking regulated +/-15 volt supply and a stereo headphone amplifier which gives the user a mixed output for non studio use.

Voltage Regulator

The Audio Rack (AR) unit is supplied with 3 amp regulated +/-15 volt supply by a tracking regulator IC (LM325) and associated bypass transistors. This regulator also supplies the Op-amps on the CMI-310.

Headphone Amplifier

The headphone amplifier is for amplifying the stereo outputs from both mixer modules which may be inserted in the audio rack. It consists of two LM380 IC amplifiers which are fed buffered signals from the audio motherboard. It can also mix the metronome output if desired.

Rectification and Filtering

(refer schematic CMI310-01)

The Alternating Current from the toroidal transformer comes in on connector SO1 (15 way). Various windings are used to generate the voltages for the CMI.

Connections 1 and 2 (16vac) are rectified by BR5, filtered by C34 and fused by F8 to supply the music keyboard +18 volts. LED 8, if inserted, confirms the fuse condition. LEDs 1 through 10 are not normally inserted as the CMI has these leds mounted on the rear panel circuit board CMI-317.

Connections 3 and 4 (16vac) are rectified by BR4 filtered by C33 and fused by F7 to supply the music keyboard -18 volts. LED 7, if fitted, shows the fuse state.

Connections 5 and 6 (9vac) are rectified by BR2, filtered by C30, fused by F6 to feed the music keyboard +10 volts. LED 6 shows the fuse state.

Connections 7, 8 and 9 (+/-18vac) are rectified by BR3, filtered by C31 and C32, fused by F4 and F5 to supply the Audio Rack 15 volt regulator (see later circuit description). LEDs 4 and 5 indicate fuse condition.

Connections 10, 11, 12 and 13 (+18,+8,common and -18vac respectively) are for the sampling card supply.

Connections 10 and 13 (+18, -18vac with reference to pin 12) are rectified by BR1 filtered by C27 and C28 and fused by F2 and F3 to supply the sampling card +20 and -20vdc supplies. LEDs 2 and 3 show the fuse states.

Connection 11 (8vac with reference to pin 12) is rectified by D5, filtered by F1 to feed the +10 volts DC to the sampler.

Connections 14 and 15 are the 16vac for the VDU which is fused by F9. LED 9 indicates the fuse condition.

CMI-310 Audio PSU & Headphone Amp

Voltage Regulator

(refer schematic CMI310-02)

The +/- 15 volt regulation for the Audio modules is provided by the LM325 IC and bypass transistors T1 and T2. Resistor R36 provides the current limit of just over 3 amps for the +15 volt while R39 provides the -15 volt limit. Diodes D7 and D2 protect transistors T1 and T2 from excessive reverse voltage during transient conditions at power up and power down times.

Diode D3 and Thyristor TH1 (C122E) are a crowbar protection circuit for the +15 volt supply to help prevent faulty transistors from damaging audio circuitry. Similarly D4, Q1 and TH2 protect the -15 volt supply from over voltage. These operate by sensing an over-voltage condition and firing the thyristor to blow the fuse. This saves the audio circuitry from damage.

Headphone Amplifier

(refer schematic CMI310-03 -05)

The incoming audio signals are buffered by IC 1M,L (LF347) then converted to unipolar signals and filtered to remove high frequency noise (induced from various sources into the Audio Motherboard and cabling) by IC 2M (LF353). The metronome is buffered by IC 2L then fed to the metronome level pot and again buffered before being mixed into the headphone amplifiers.

The audio signal from the level pot is mixed with the metronome output and passed through a simple filter then amplified by the LM380s (one for right and one for left). The inverting input is used on the LM380 for improved stability with a high impedance source. A 470 uF cap provides DC isolation for the output and a 10R protects from short circuit loads. The 7815 regulator provides a direct low impedance supply for the LM380s to improve isolation and stability.

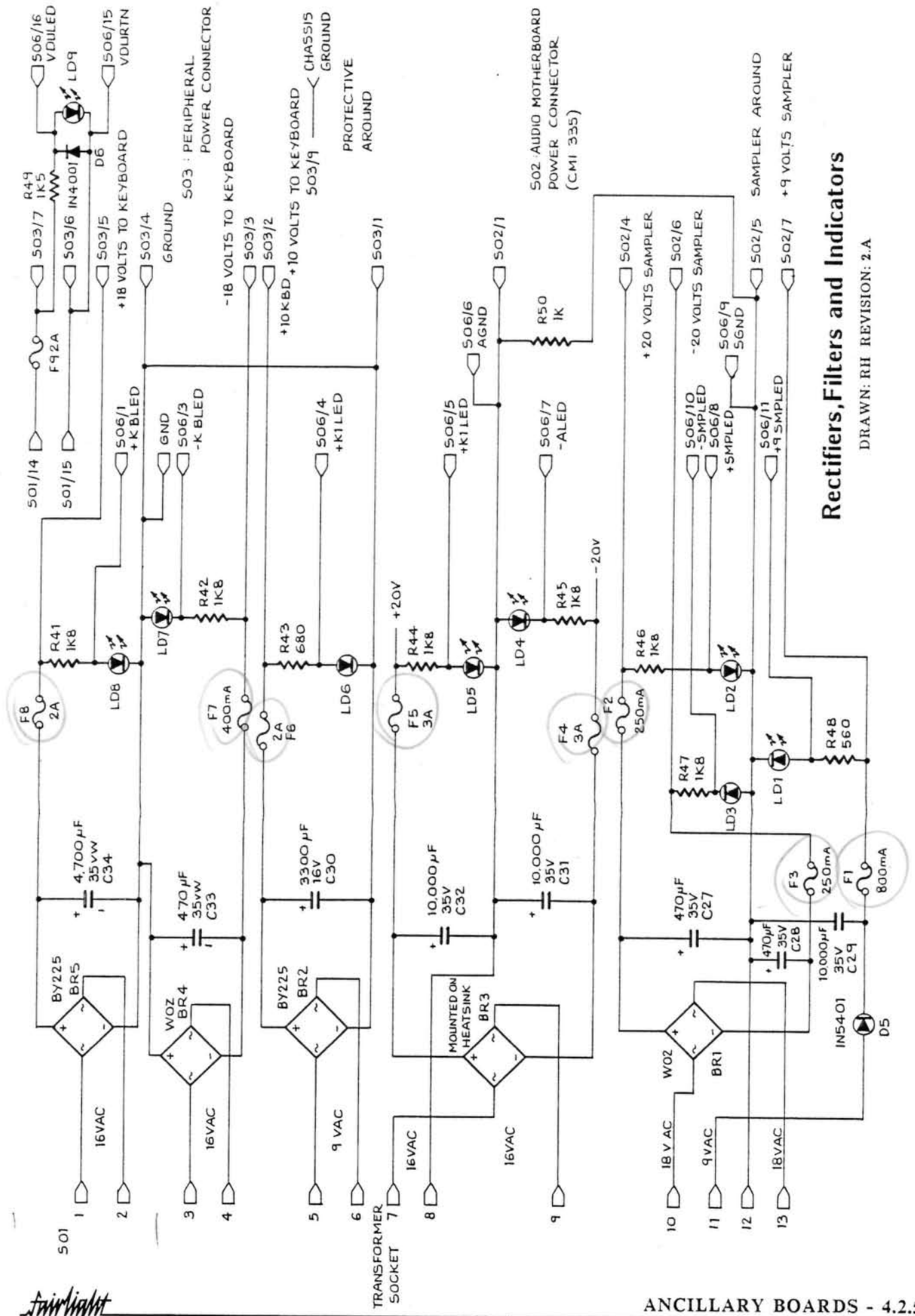

Rectifiers, Filters and Indicators

DRAWN: RH REVISION: 2.A

twilight

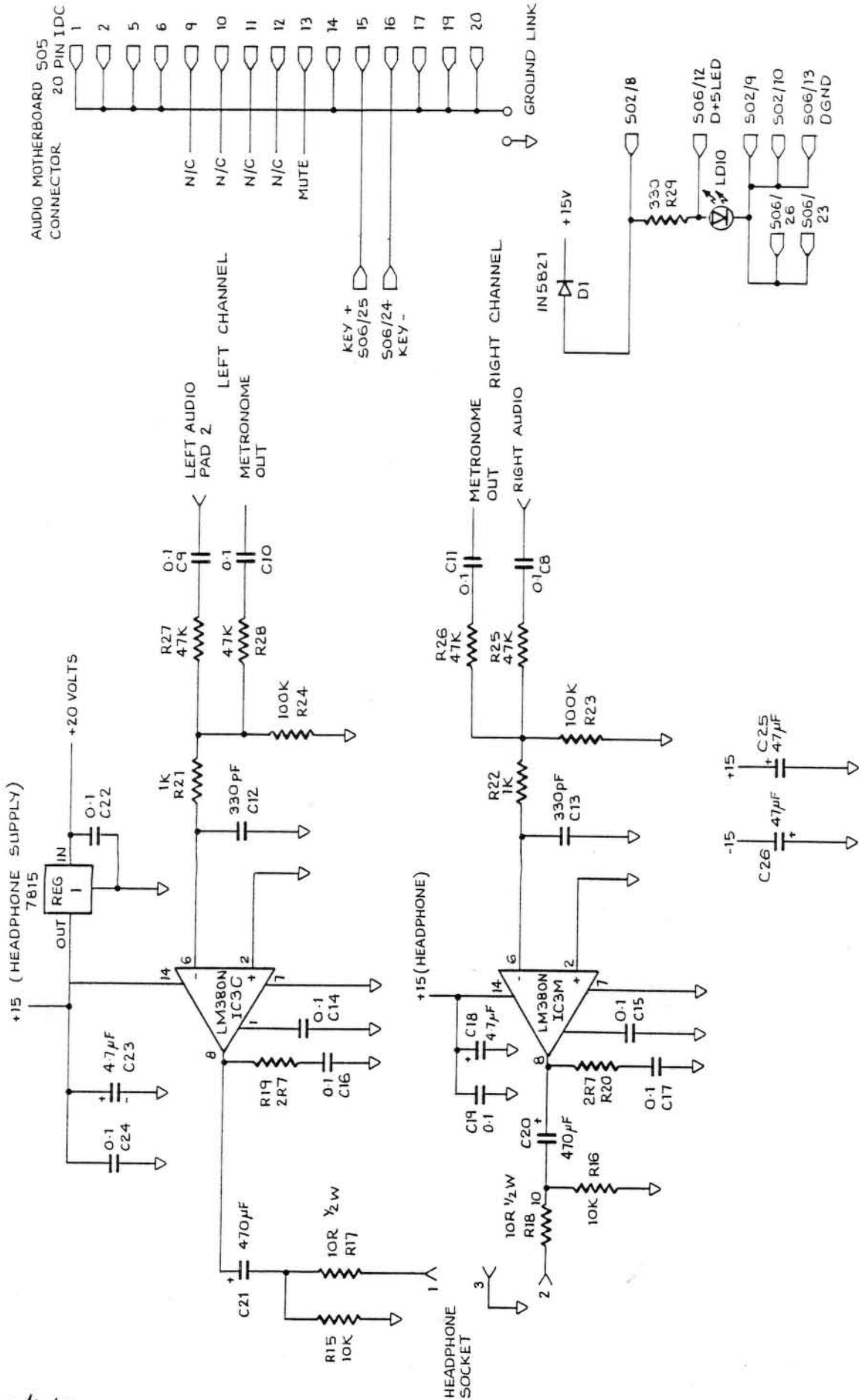

Headphone Mixer and Metronome

DRAWN: RH REVISION: 2.A

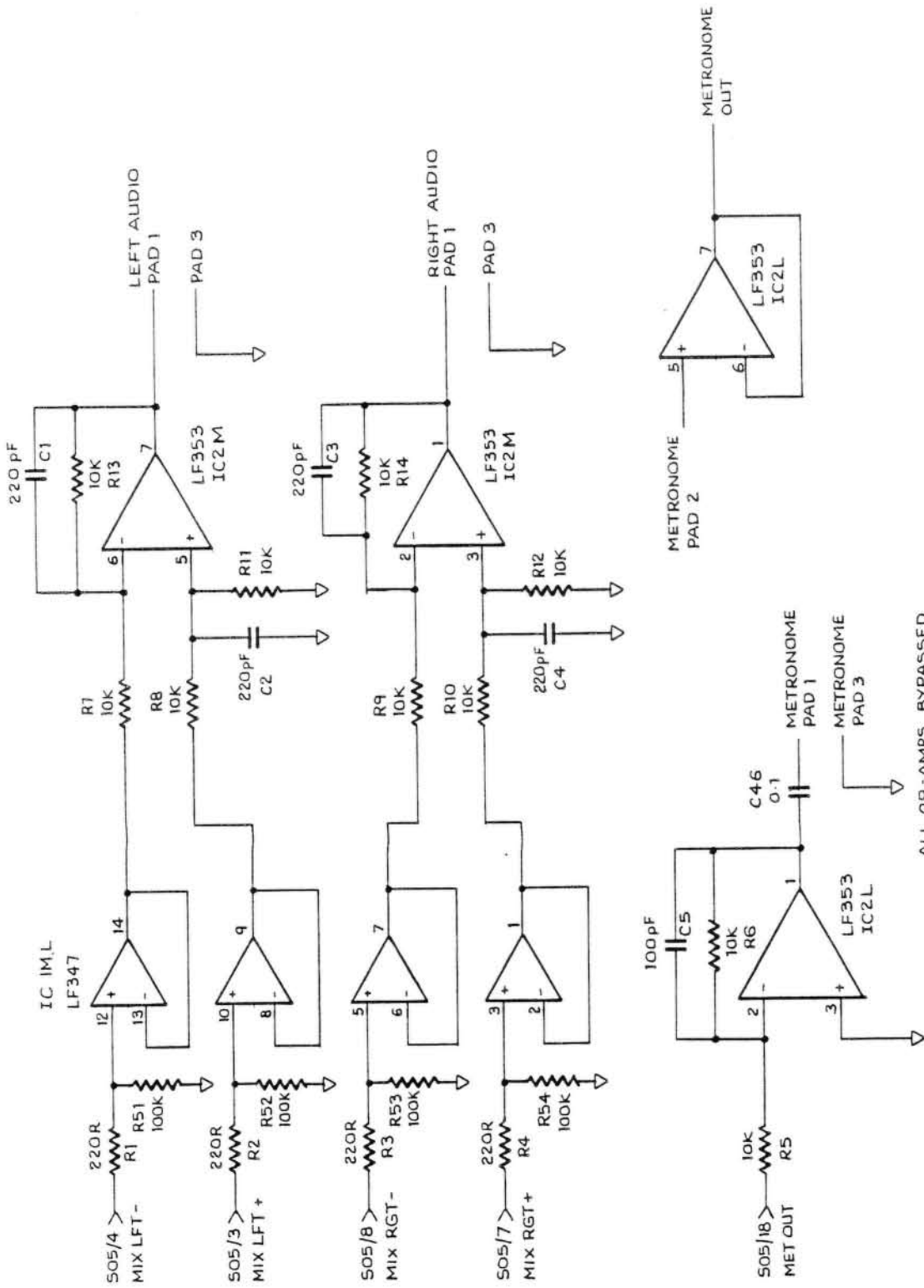

ALL OP-AMPS BYPASSED BY 0.1 FROM +V TO AGND AND FROM -V TO AGND

Audio Buffers and Mixing

DRAWN: RH REVISION: 2.A

CMI-317

Peripheral Connector Board

4.3

Introduction.....	4.3.2
Detailed circuit description.....	4.3.3
Circuit diagrams.....	4.3.4

CMI-317 Peripheral Connector Board

Introduction

The Peripheral Connector Card is located on the rear panel of the Series III mainframe assembly at the left hand end. Its function is to interface the power, signals and video input and output from the various parts of the CMI to the external components of a complete system. The card exists only as an interconnection medium and display device for the power supply fuse state (The leds represent the fuse state on card CMI-10)

Detailed Circuit Description

(refer schematic CMI-17-01,-02,-03)

The circuit diagram consists mainly of a schedule of pinouts of the various connectors involved. The input connectors are shown on sheet CMI-17-01, P1 is a 9 pin power connector for the cable from the C.M.I 310 power supply, P2 is an IDC ribbon cable type connector from the C.M.I 310 and carries the LED signals to indicate fuse condition and also MIDI signals from the music keyboard (from CMI-10 MIDI is re-directed up to CMI-32 MIDI module in the audio rack, via CMI-35, and then to CMI28 in the digital card cage for processing), P3 is a 10 pin IDC ribbon cable type connector which carries the serial data to the printer ports (S6 and S7), P4 is a MOLEX type wafer connector which receives the composite video signal to be sent to the monitor.

Outputs are shown on sheet CMI-17-02: S4 connects the keyboards to the CMI (note the connection between pins 5 and 7, this is the only change between rev 1 and 2 however all rev 1 boards were fitted with this as a modification before shipment. S5 is the music keyboard power connector. S6 & S7 are serial printer sockets. S8 is the video out and monitor power connector.

The display LEDs are shown on sheet CMI-17-03, their functions are labelled. Note that the series dropping resistors are located on CMI-310 power supply.

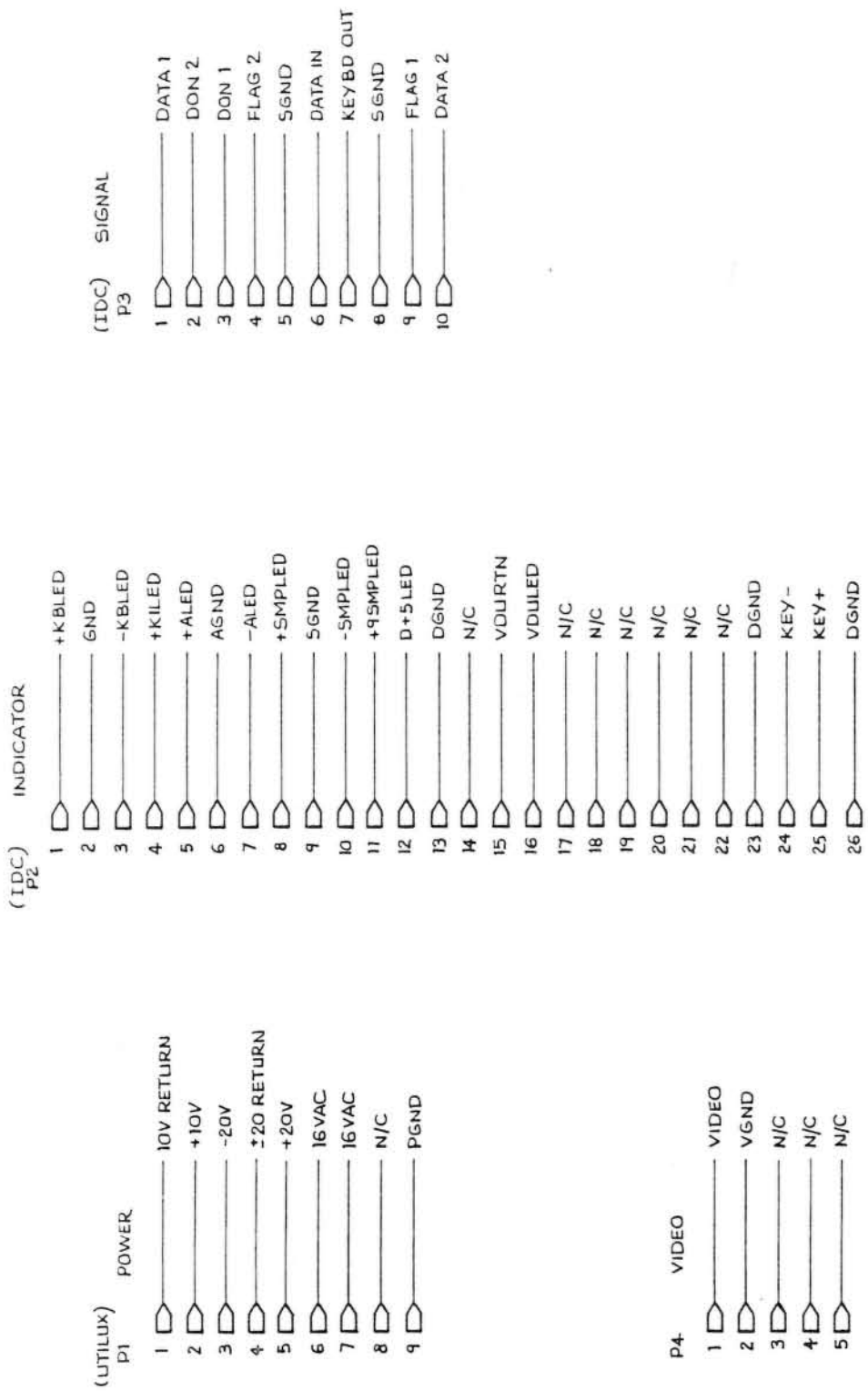

Data Connectors etc., Input

DRAWN: RH

CMI-317-02 Peripheral Connector Board

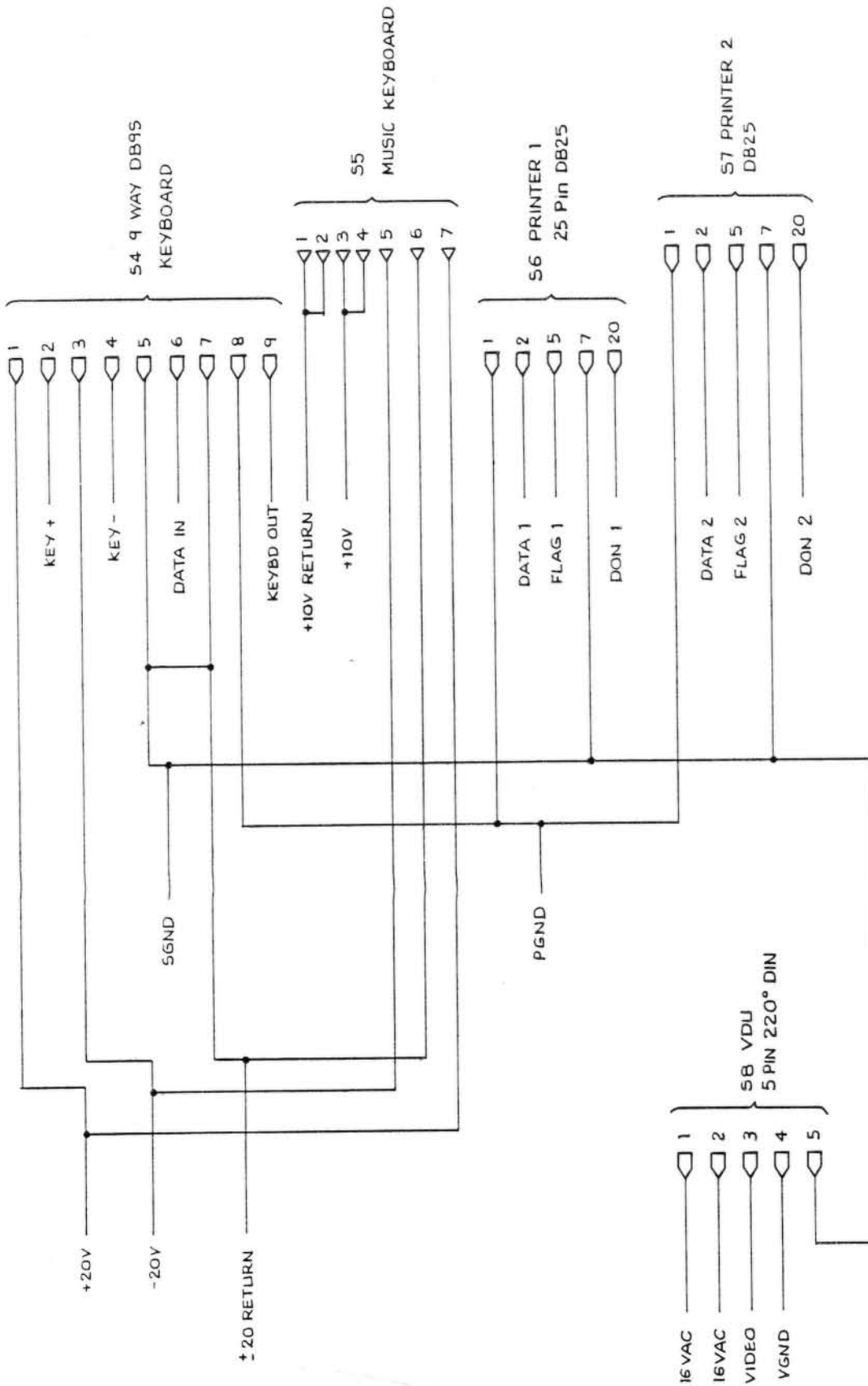

Output Connectors

DRAWN: RH

Led Indicators
DRAWN: RH

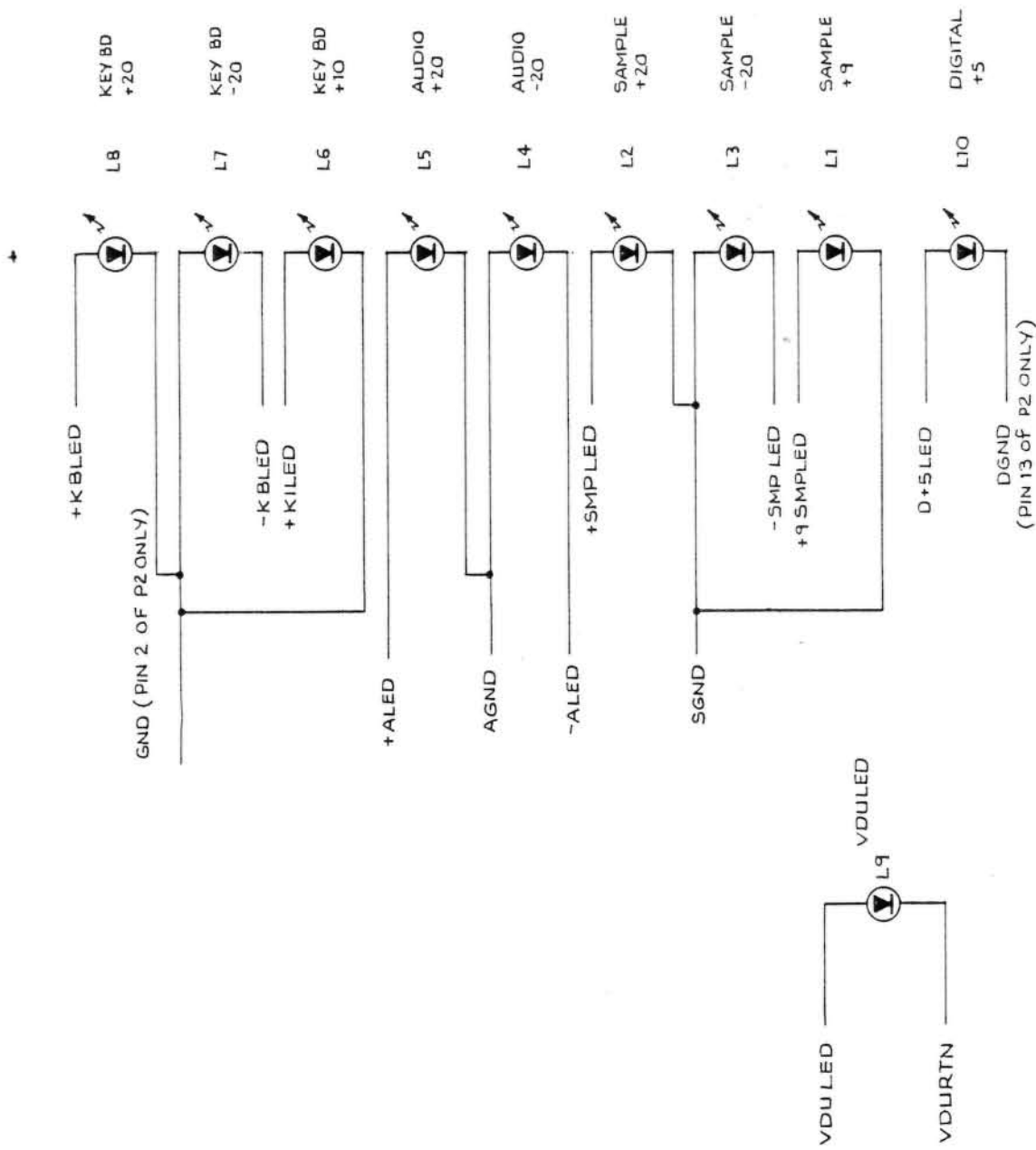



Internal Cabling

4.4

Introduction.....	4.4.2
Table 1 - SCSI Interface Cable.....	4.4.2
Table 2 - Graphics Cable.....	4.4.3
Table 3 - Serial Port Cable.....	4.4.4
Table 4 - MIDI and LED Cable.....	4.4.4
Table 5 - Headphone signals and MIDI cable.....	4.4.5
Table 6 - Floppy Disc Cable.....	4.4.6
Table 7 - MIDI and SMPTE Cable.....	4.4.7
Table 8 - Debug Cable.....	4.4.8
Table 9 - Waveform Data Cable.....	4.4.9
Table 10 - Data Control Cable.....	4.4.10
Table 11 - Sampling Cable.....	4.4.11
Table 12 - Front Panel Cable.....	4.4.11
Cable wiring diagram for mainframe.....	4.4.13
Power wiring diagram for mainframe.....	4.4.15

INTERNAL CABLE SCHEDULE

Introduction

This cable schedule is for use in reference to the Cable Wiring diagram for CMI Series III Mainframe. The Series III uses IDC type ribbon cabling where possible to provide high reliability and ease of manufacture. This collection of tables gives the signal names of each conductor within the ribbon cable and source or destination of each cable.

Table 1

SCSI Interface Cable

Source: Q777 SCSI Interface Adapter

Destination: ADAPTEC Disk Controller, EMULEX Tape Controller,
External SCSI Connector.

Pin	Signal Name	Signal Function	Origin
1	GND	signal ground	Q777
2	DB0	data bus 0	Q777
3	GND	Q777	
4	DB1	data bus 1	Q777
5	GND	Q777	
6	DB2	data bus 2	Q777
7	GND	Q777	
8	DB3	data bus 3	Q777
9	GND	Q777	
10	DB4	data bus 4	Q777
11	GND	Q777	
12	DB5	data bus 5	Q777
13	GND	Q777	
14	DB6	data bus 6	Q777
15	GND	Q777	
16	DB7	data bus 7	Q777
17	GND	Q777	
18	unused		
19	GND		Q777
20	unused		
21	GND		Q777
22	unused		
23	GND		Q777
24	unused		

INTERNAL CABLE SCHEDULE

25	GND		Q777
26	unused		
27	GND		Q777
28	unused		
29	GND		Q777
30	unused		
31	GND		Q777
32	ATN	attention	Q777
33	GND		Q777
34	unused		
35	GND		Q777
36	BSY	busy	Q777
37	GND		Q777
38	ACK	acknowledge	Q777
39	GND		Q777
40	RST	reset	Q777
41	GND		Q777
42	MSG	message	Q777
43	GND		Q777
44	SEL	select	Q777
45	GND		Q777
46	C/D	control/data	Q777
47	GND		Q777
48	REQ	request	Q777
49	GND		Q777
50	I/O	input/output	Q777

Table 2

Graphics Cable

Source: Q219 Graphics Card (10 pin IDC)

Destination: CMI317 peripheral connector panel (5 pin Molex type)

Q219 Pin	Signal Name	CMI317 Function	Pin
1-6	unused		
7	VIDEO	composite video out	1
8	GND	signal ground	2

INTERNAL CABLE SCHEDULE

Table 3
Serial Port Cable
Source: Q133 CPU Control Card
Destination: CMI317 peripheral connector panel

Pin	Signal Name	Function	Signal Origin
1	DOUT0	Printer 1 data out	Q133
2	DON1	Printer 2 Device On (DTR) output	Q133
3	DIN0	Printer 1 Device On (DTR) output	Q133
4	FLG1	Printer 2 Flag (DSR) input	CMI317
5	DGND	Digital Ground	Q133
6	DIN	Keyboard (RS232) data in	CMI317
7	KBDOUT	Keyboard (RS232) data out	Q133
8	DGND	Digital Ground	Q133
9	FLG0	Printer 1 Flag (DSR) input	CMI317
10	DOUT1	Printer 2 data out	Q133

Table 4
MIDI and LED cable
Source: CMI310 power supply
Destination: CMI317 peripheral connector panel

Pin	Signal Name	Function	Signal Origin
1	+KBLED	keyboard power +20 volts LED	CMI310
2	GND	keyboard power return LED	CMI310
3	-KBLED	keyboard power -20voltsLED	CMI310
4	+K1LED	keyboard power +10 volts LED	CMI310
5	+ALED	audio +20 volts LED	CMI310
6	AGND	audio LED return	CMI310
7	-ALED	audio -20 volts LED	CMI310
8	+SMPLLED	sampler +20 volts LED	CMI310
9	SGND	sampler LED return	CMI310
10	-SMPLLED	sampler -20 volts LED	CMI310
11	+9SMPLLED	sampler +9 volts LED	CMI310
12	D+5LED	digital 5 volts LED	CMI310
13	DGND	digital GND	CMI310
14	n/c		
15	VDURTN	VDU LED return	CMI310
16	VDULED	VDU LED signal	CMI310
17-22	n/c		
23	DGND	digital GND	CMI310
24	KEY- ¹	MIDI from music KBD	CMI317
25	KEY+ ¹	MIDI from music KBD	CMI317
26	DGND	digital GND	CMI310

Note 1: The MIDI from the music keyboard is routed from the CMI317 through to CMI310 then to CMI335 and CMI332 where it is transmitted to the MIDI processor.

Table 5

Headphone signals and MIDI cable

Source: CMI335 Audio Motherboard

Destination: CMI310 Power Supply

This cable connects the various signals from plug in cards connected to CMI335 and routes them to CMI310. CMI335 has no electronics self contained.

Pin	Signal Name	Function	Signal Origin
1	AGND	analog GND	CMI335
2	AGND	analog GND	CMI335
3	MIXLFT+	mixed output left channel	CMI335
4	MIXLFT-	mixed output left channel	CMI335
5	AGND	analog GND	CMI335
6	AGND	analog GND	CMI335
7	MIXRT+	mixed output right channel	CMI335
8	MIXRT-	mixed output right channel	CMI335
9-12	n/c		
13	MUTE	mute control line	various
14	AGND	analog GND	CMI335
15	KEY+	MIDI from music keyboard	CMI310
16	KEY-	MIDI from music keyboard	CMI310
17	AGND	analog GND	CMI335
18	METOUT	metronome output to headphone	CMI335
19	AGND	analog GND	CMI335
20	AGND	analog GND	CMI335

INTERNAL CABLE SCHEDULE

Table 6

Floppy disc cable

Source: QFC9 Floppy disc controller

Destination: Floppy disc drive

Pin	Signal Name	Signal Function	Origin
1	unused		
2	GND	Ground	QFC9
3	unused		
4	HDL3	unused	QFC9
5	READ DATA		drive
6	HDL2	unused	
7	WRITE PROTECT		drive
8	unused		
9	TRACK 0		drive
10	unused		
11	WRITE GATE		QFC9
12	unused		
13	WRITE DATA		QFC9
14	unused		
15	STEP		QFC9
16	unused		
17	DIRECTION		QFC9
18	unused		
19	DS4	Drive select	QFC9
20	unused		
21	DS3	Drive select	QFC9
22	unused		
23	DS2	Drive select	QFC9
24	unused		
25	DS1	Drive select	QFC9
26	unused		
27	unused		
28	HDL1	unused	
29	READY		drive
30	unused		
31	INDEX		drive
32	unused		
33	HEAD LOAD		QFC9
34	HDL0	unused	
35	ALT	unused	
36	IN USE	unused	
37	SIDE SELECT		QFC9
38	unused		
39	unused		
40	DISK CHANGE		drive
41	unused		
42	TWO SIDE		drive
43-48	unused		
49	LOW CURRENT	write current control	QFC9

Table 7

MIDI and SMPTE cable

Source: CMI28 General Interface Card

Destination: CMI335 Audio Motherboard

The signals connecting to CMI335 are actually routed to CMI332 and CMI333 which plug in to CMI335.

Pin	Signal Name	Function	Signal Origin
1	MIDI OUT A	MIDI output A	CMI28
2	D+5	digital 5 volts	CMI28
3	MIDI IN A	MIDI input A	CMI335
4	SYNC OUT 1	sync output	CMI28
5	MIDI OUT B	MIDI output B	CMI28
6	SYNC OUT 2	sync output	CMI28
7	MIDI IN B	MIDI input B	CMI335
8	SYNC OUT 3	sync output	CMI28
9	MIDI OUT C	MIDI output C	CMI28
10	DGND	digital GND	CMI28
11	MIDI IN C	MIDI input C	CMI335
12	DGND	digital GND	CMI28
13	MIDI OUT D	MIDI output D	CMI28
14	RESET/START	drum machine control	CMI28
15	MIDI IN D	music keyboard MIDI input	CMI335
16	RUN/STOP	drum machine control	CMI28
17	SMPTE IN	SMPTE time code input	CMI335
18	DGND	digital GND	CMI28
19	SMPTE OUT	SMPTE time code output	CMI28
20	CLICK OUT	click track output	CMI28
21	CLICK IN	click track in	CMI335
22	n/c		
23	CPU HALT	MIDI processor halt	CMI28
24	DGND	digital GND	CMI28
25	CPU RESET	MIDI processor reset	CMI28
26	DGND	digital GND	CMI28

INTERNAL CABLE SCHEDULE

Table 8

Debug cable

Source: Q133 CPU Control Card (Debug Card)

Destination: CMI335 Audio Motherboard.

The signals connected to the CMI335 card are actually routed to CMI334 or other cards plugged into CMI335.

Pin	Signal Name	Function	Signal Origin
1	CB2	Debug PIA line	Q133
2	DGND	digital GND	Q133
3	CB1	Debug PIA line	Q133
4	DGND	digital GND	Q133
5	B7	Debug PIA line	Q133
6	B6	Debug PIA line	Q133
7	B5	Debug PIA line	Q133
8	B4	Debug PIA line	Q133
9	B3	Debug PIA line	Q133
10	B2	Debug PIA line	Q133
11	B1	Debug PIA line	Q133
12	B0	Debug PIA line	Q133
13	DGND	digital GND	Q133
14	DGND	digital GND	Q133
15	A7	Debug PIA line	Q133
16	A6	Debug PIA line	Q133
17	A5	Debug PIA line	Q133
18	A4	Debug PIA line	Q133
19	A3	Debug PIA line	Q133
20	A2	Debug PIA line	Q133
21	A1	Debug PIA line	Q133
22	A0	Debug PIA line	Q133
23	DGND	digital GND	Q133
24	CA2	Debug PIA line	Q133
25	DGND	digital GND	Q133
26	CA1	Debug PIA line	Q133

Table 9

Waveform Data Cable

Source: CMI32 Channel Support Card

Destination: CMI335 Audio Motherboard

The signals connected to the audio motherboard are routed to slots 2 through 9 where they connect to the 8 audio modules.

Pin	Signal Name	Function
1	D0+	bit 0 Least significant bit
2	D0-	bit 0
3	D1+	bit 1
4	D1-	
5	D2+	bit 2
6	D2-	
7	D3+	bit 3
8	D3-	
9	D4+	bit 4
10	D4-	
11	D5+	bit 5
12	D5-	
13	D6+	bit 6
14	D6-	
15	D7+	bit 7
16	D7-	
17	D8+	bit 8
18	D8-	
19	D9+	bit 9
20	D9-	
21	D10+	bit 10
22	D10-	
23	D11+	bit 11
24	D11-	
25	D12+	bit 12
26	D12-	
27	D13+	bit 13
28	D13-	
29	D14+	bit 14
30	D14-	
31	D15+	bit 15
32	D15-	
33	DGND	digital GND
34	DGND	digital GND

INTERNAL CABLE SCHEDULE

Table 10

Data Control Cable

Source: Channel Cards CMI31

Destination: CMI335/CMI331 Audio Modules

Pin	Signal Name	Function	Signal Origin
1	VCA1	VCA control channel 1	CMI31
2	VCA2	VCA control channel 2	CMI31
3	VCF1	VCF control channel 1	CMI31
4	VCF2	VCF control channel 2	CMI31
5	RES1	resonance control channel 1	CMI31
6	RES2	resonance control channel 2	CMI31
7	+15V	regulated supply from audio	CMI331
8	AGND	analog GND	CMI331
9	AGND	analog GND	CMI331
10	-15V	regulated supply from audio	CMI331
11	n/c		
12	n/c		
13	n/c		
14	DCLK+2	data latch signal channel 2	CMI31
15	DCLK-2		
16	DCLK+1	data latch signal channel 1	CMI31
17	DCLK-1		
18	PCLK+1	pitch clock signal channel 1	CMI31
19	PCLK-1		
20	PCLK+2	pitch clock signal channel 2	CMI31
21	PCLK-2		
22	DGND	digital GND	CMI31
23	DGND	digital GND	CMI31
24	n/c		
25	n/c		
26	n/c		

Table 11

Sampling Cable

Source: CMI33 Waveform Processor

Destination: CMI335 Audio Motherboard socket J4, then signals are routed to the CMI337 Sampling Card (ADC) edge connector (slot 1).

Pin	Signal Name	Function	Signal Origin
1	DATA IN+	ADC data current loop	CMI337
2	DATA IN-		
3	CLOCK+	Bit clock current loop	CMI337
4	CLOCK-		
5	EOC+	End of Conversion current loop	CMI337
6	EOC-		
7	DATA OUT+	Control data current loop	CMI33
8	DATA OUT-		
9	START+	Start conversion command loop	CMI33
10	START-		

Table 12

Front Panel Cable

Source: Q133 CPU Control Card

Destination: Q137 Front Panel

Pin	Signal Name	Function	Signal Origin
1	GND	Digital ground	Q133
2	RxD	Comms data in	Q137
3	TxD	Comms data out	Q133
4	CTS	Clear To Send to CMI	Q137
5	DCD	Data Carrier Detect to CMI	Q137
6	RTS	Request To Send from CMI	Q133
7	RX+	RS422 data in	Q137
8	RX-		
9	TX+	RS422 data out	Q133
10	TX-		
11	GND	Digital ground	Q133
12	RES1	P1 reset	Q137
13	RES2	P2 reset	Q137
14	NMI1	P1 console interrupt	Q137
15	CMI2	P2 console interrupt	Q137
16	HLT1	P1 halt	Q137
17	HLT2	P2 halt	Q137
18	-12V	-12V to power-on LED	Q133
19	+12V	-12V to power-on LED	Q133
20	+5V	+5V to power-on LED	Q133

