

CMI-331

AUDIO OUTPUT MODULE

THE
MOUNTAIN



FIELD CHANGE NOTICE

DATE 8 / 6 / 93
NUMBER 129

ORIGINATOR Chris Alfred

PRODUCT: CMI / MFX

ASSEMBLY No. CMI-331

DESCRIPTION Audio Output Module

This FCN applies to REV No: Rev 2

New REV No is: Rev 2.1

REASON FOR CHANGE:

This is a new revision of art work.

PCB errors and component changes.

For production documentation only, to be done on all new cards.

DETAILS OF CHANGE:

1. Remove R128 (75 ohm)
2. Remove R147 (75 ohm)
3. Replace R1 with wire link
4. Replace R2 with wire link

ORIGINATOR:	DATE:	TEST:	DATE:
		PROD: <i>M. Pedone</i>	DATE: 17/6/93
SERVICE:	DATE: 17/6/93	KIT LIST CHANGE: <input checked="" type="radio"/> YES <input type="radio"/> NO	



FIELD CHANGE NOTICE

DATE 16/ 12/ 92
NUMBER 114

ORIGINATOR Shane Morris

PRODUCT: CMI / MFX

ASSEMBLY No. CMI 331 DESCRIPTION Audio output

This FCN applies to REV No: 1B10

The New REV No is: 1B11

REASON FOR CHANGE:

To remove low level distortion from the audio output signal.

This modification can be applied to any revision of the C M I 331.

DETAILS OF CHANGE:

Follow attached information.

LABEL AS 1B11 or 1B7.3 (upgrade machines)
(new)

ORIGINATOR: <i>Shane Morris</i>	DATE: <i>17/12/92</i>	PROD: <i>Maxie Pashia</i>	DATE: <i>21/12/92</i>
SERVICE:	DATE:	KIT LIST CHANGE:	<input checked="" type="radio"/> YES <input type="radio"/> NO

ESP-399 SAMPLE & HOLD INSTALLATION INFORMATION

Date: 8 December 1992

1. Remove R78 and R80.
2. Remove R79 and place on solder side of CMI-331. Cut resistor legs so they do not protrude through the pcb on the component side.
3. Unsolder and CAREFULLY lift pins 11 and 13 of IC A5,6.
4. Remove C11.
5. Desolder pins 4,5, and 8 of IC L11 OR if IC L11 is used solder directly onto pins. See point 9.
6. Remove the centre pin of the 3 x 3 way vertical connectors. Plug "3 way" vertical pins into the 3 x female sockets on solder side of ESP-399.
- 7.a Connect "clock A out" to isolated PCB pad at pin 11 IC A5,6.
- 7.b Connect "clock B out" to isolated PCB pad at pin 13 IC A5,6.
- 7.c Connect "clock A in" directly to pin 11 of IC A5,6.
- 7.d Connect "clock B in" directly to pin 13 of IC A5,6,7.

After the 4 connections have been made CAREFULLY fold cable, and attached ESP-399 assy. over IC A5,6 then do an immediate right angle fold toward R2 / R3 then at R2 / R3 right angle fold toward centre of CMI-331. Then one last right angle fold to be able to install at C11, R80 and R78.

8. Check that the height of ESP-399 is within the module width, i.e. that all connectors are flush with the pcb.
9. Connect analog power and analog ground at IC L11. Pin 4 -V, pin 5 analog ground, pin 8 +V. See connection diagram.
10. Check all connections. Plug CMI-331 into extender and turn machine on.
11. At step 1 of audio cal press "SET" then "A" SPACE BAR then type "60" <return>. With test unit with 20Hz to 20kHz filter ON THD+N will be better than -30dB or 5% THD+N.

NOTE: This presumes the audio cal has been done per the audio card alignment procedure.

ESP-399 SAMPLE & HOLD CONNECTIONS

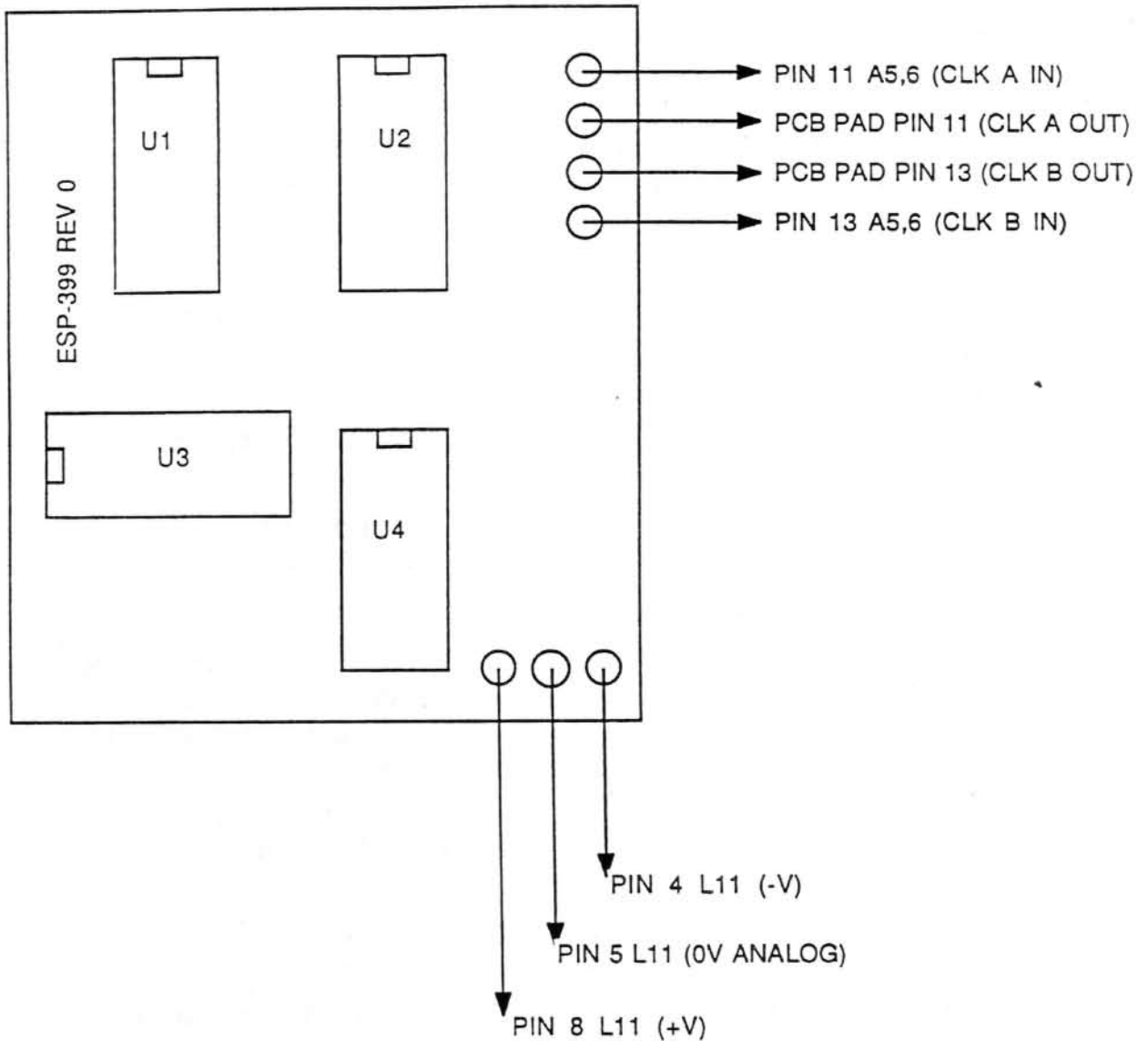

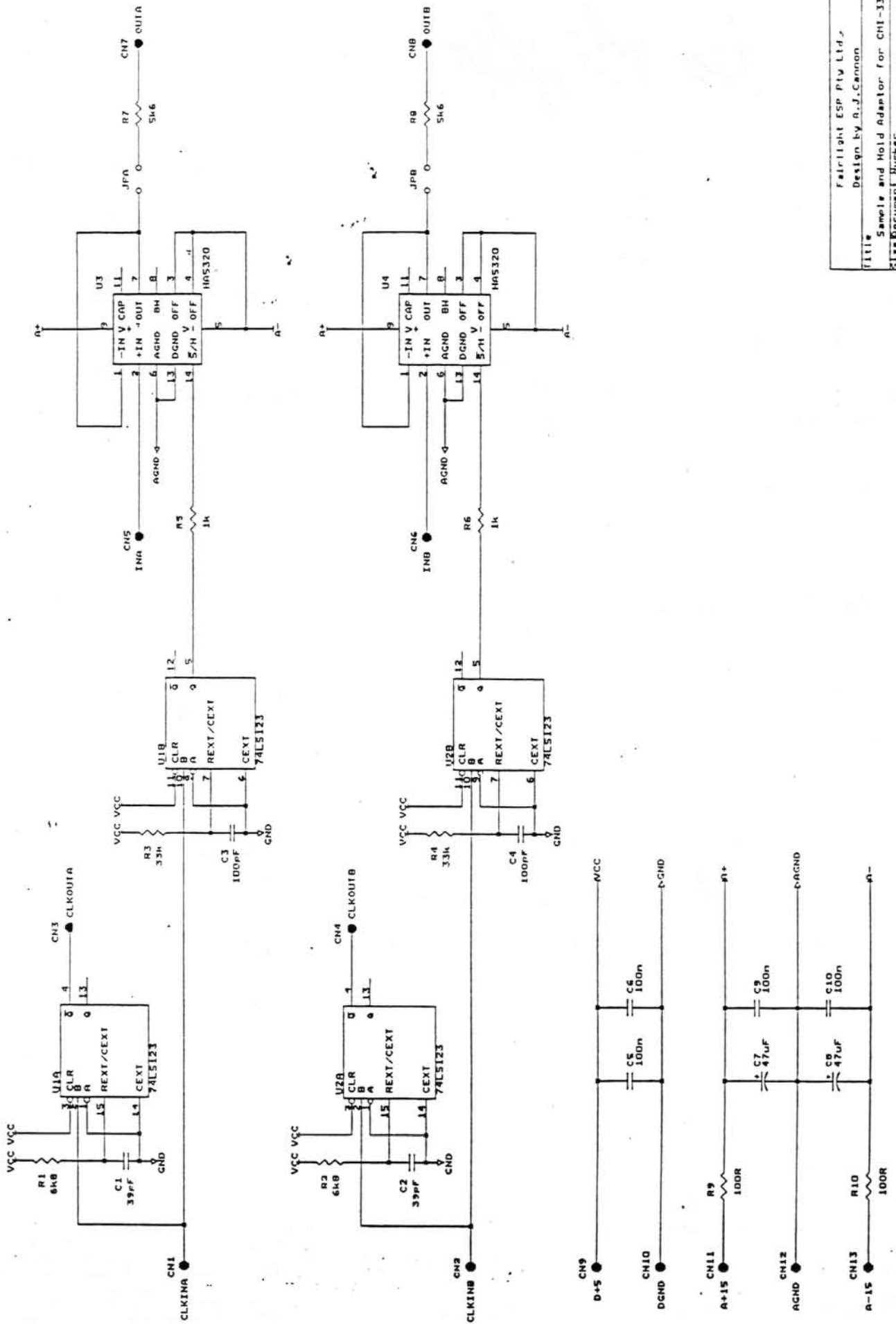

Fairlight ESP Pty Ltd.
 Design by A.J. Cannon
 Title Sample and Hold Adapter for CHI-331
 File Document Number B ESP-399-01 REV 0
 Date 02 October 21, 1992 Sheet 1 of 1



FIELD CHANGE NOTICE

DATE 2/10/92
NUMBER 107

ORIGINATOR Andrew Cannon

PRODUCT: CMI / MFX

ASSEMBLY No. CMI-331 DESCRIPTION Audio output card

This FCN applies to REV No: 1B8 & 1B9 only The New REV No Is: 1B10

REASON FOR CHANGE:

According to FCN 103 changes were made to VCF resistor values to improve the temperature stability. This has resulted in an increase of noise pick up as a result of the higher source impedance driving the DBX chips.

THIS FCN LOWERS THE VALUES

DETAILS OF CHANGE:

FOR CHANNEL A.....



- Remove C34, C41, C43, C47 replace with 1000pF caps 2.5%
- Remove R117 replace with 7k32 1% or place 27k 1% in parallel with 10k 1% in place
- Remove R94 replace with 11k3 1% or place 15k 1% in parallel with a 47k 1 %
- Remove R90, R91, R114, R115 replace with 6k2 1%

FOR CHANNEL B.....

- Remove C23, C25, C27, C28 replace with 1000pF caps 2.5%
- Remove R30 replace with 7k32 1% or place 27k 1% in parallel with 10k 1% in place
- Remove R45 replace with 11k3 1% or place 15k 1% in parallel with a 47k 1 %
- Remove R29, R31, R42, R53 replace with 6k2 1%

Follow realignment procedure of VCF FOR 1B8 AND 1B9 CARDS

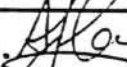
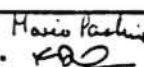
Overall noise improvement of 6dB should result to a level of -94dBr (0dBr = +25dB out channel output XLR)

ORIGINATOR: 	DATE: 2/10/92	PROD:  Hario Pashis	DATE: 2/10/92
SERVICE: 	DATE: 2/10/92	KIT LIST CHANGE:	<input checked="" type="checkbox"/> YES <input type="checkbox"/> NO

Starlight

Page 1 of 6

FIELD CHANGE NOTICE

DATE 25/ 8 / 92

NUMBER 103

ORIGINATOR Shane Morris

PRODUCT: CMI / MFX

ASSEMBLY No. CMI-331 DESCRIPTION Audio Output card

This FCN applies to REV No: 1B7.1 & 1B8 The New REV No is: 1B7.2 & 1B9

REASON FOR CHANGE:

VCF cut off attenuation on channel A suffering from cross talk.
Max attenuation VCA cross talk.
Reduce distortion at high frequencies.

DETAILS OF CHANGE:

Check and verify all FCN's concerned with the CMI331 (FCN 66, FCN 74, FCN 93) all of these FCN's will bring the audio card to REV 1B7.1 and with the exception of the temp stability mod 1B8. See circuit diagram and info of the revised VCF control circuit.

1. Check track cuts shown on diagram and add re route wires.
2. Lift resistor leg of R48
3. Remove C29 and connect to the filter output pin 5 then to the lifted leg of R48 per drawing.
4. Check wiring on under side of board from via hole to C40 and from via to C46.
- 5a For 1B7.2 add .1uF cap between pin 2&3 of J15, K15, E4/5, F4/5, I4/5, J4/5. Check the list of caps.
- 5b For 1B9 do / check FCN 93, above point 5a, attached list of capacitor additions. See circuit diagram and info for temp. stability modification. This modification is done in the production of new cards.
7. Relabel to new revision number.

ORIGINATOR: 

DATE:

SERVICE MANAGER: 

DATE: 25 Sept 1992

CARD: CMI-331

DATE: 24 August 1992

SUBJECT: TRACK CUTS FOR REVISION 1B.9 AND TO BE CHECKED ON 1B7.2

The following track cuts and modifications must be done to the audio output card to remove cross talk.

Track Cuts must be done exactly where indicated.

1. Cut track at PIN 5 of I6 (PALH 1107E). Component side.
2. Cut track at via hole. (PALH 1107E). Component side.
3. Cut track at C40. Component side.
4. Cut tracks at C46. Component side.
5. Cut track at R89. Component side
6. Cut track solder side.

NOTE: Track cuts 1,2,3,4 & 6 are associated with track routing changes. See sample.

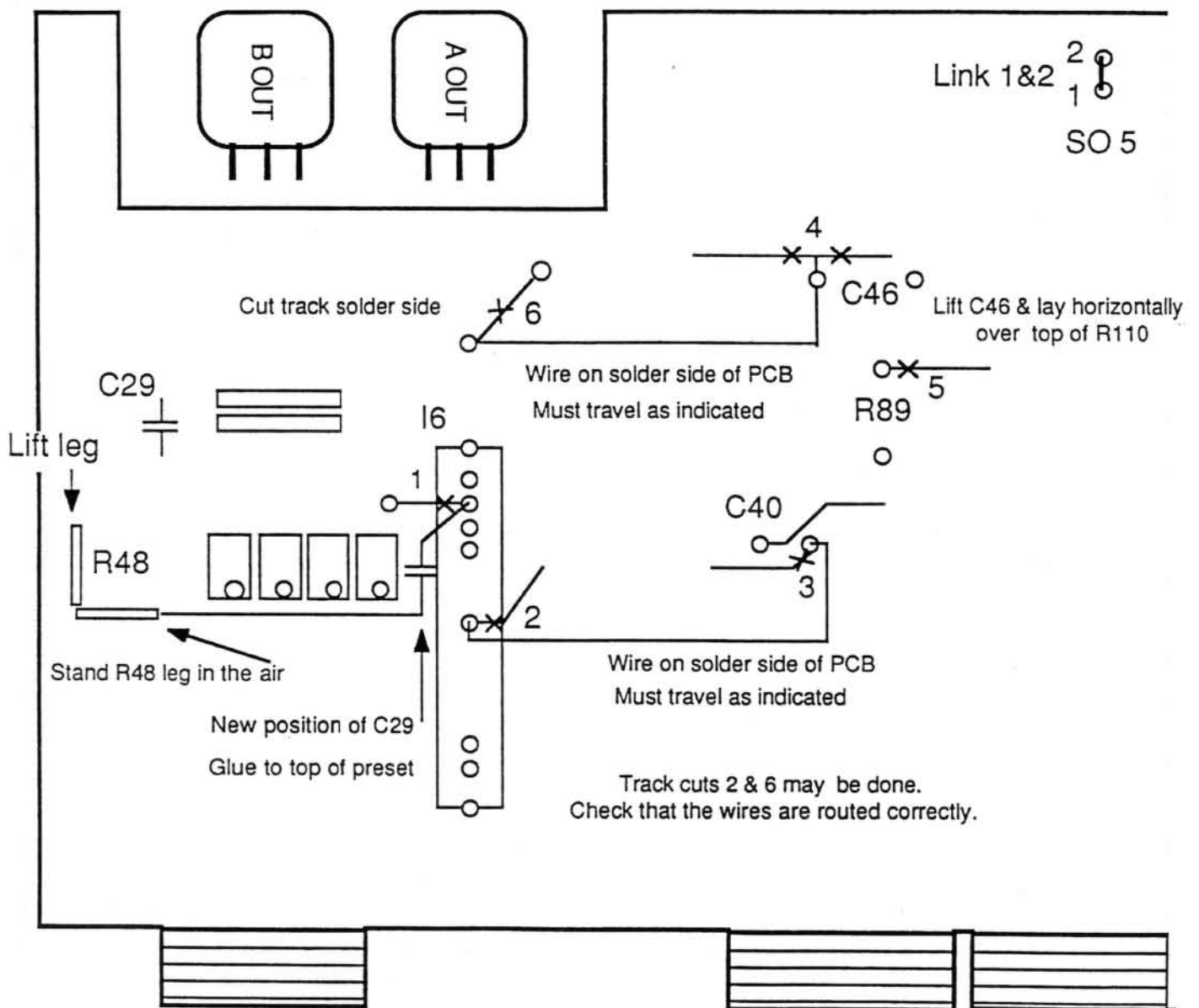

Audio Card Capacitor Additions

Date 27/8/92

I.C.	LOC	BETWEEN PINS	VALUE	FCN	APPLIES TO REV 1B7.x	APPLIES TO REV 1B9
MP7616	G15-1	15 / 20	0.1uF	103 (5b)	YES	YES
2150	K15	2 / 3	0.1uF	103 (5a)	YES	YES
2150	J15	2 / 3	0.1uF	103 (5a)	YES	YES
POT	RV5	CENTER / 0V	0.1uF	103 (5b)		YES
POT	RV6	CENTER / 0V	0.1uF	103 (5b)		YES
POT	RV7	CENTER / 0V	0.1uF	103 (5b)		YES
POT	RV8	CENTER / 0V	0.1uF	103 (5b)		YES
2150	I9,10	2 / 3	0.1uF	93	YES	YES
2150	H9,10	2 / 3	0.1uF	93	YES	YES
MP7616	G8,9	15 / 20	0.1uF	103 (5b)	YES	YES
2150	J4,5	2 / 3	0.1uF	103 (5a)	YES	YES
2150	I4,5	2 / 3	0.1uF	103 (5a)	YES	YES
POT	RV1	CENTER / 0V	0.1uF	103 (5b)		YES
POT	RV2	CENTER / 0V	0.1uF	103 (5b)		YES
POT	RV3	CENTER / 0V	0.1uF	103 (5b)		YES
POT	RV4	CENTER / 0V	0.1uF	103 (5b)		YES
2150	F4,5	2 / 3	0.1uF	103 (5a)	YES	YES
2150	F4,5	2 / 3	0.1uF	103 (5a)	YES	YES
LF347	J1,2	1 / 2	0.1uF	93	YES	YES
LF347	J1,2	6 / 7	0.1uF	93	YES	YES
LF347	D3,4	6 / 7	0.1uF	93	YES	YES
C4072	D5	1 / 2	0.1uF	93	YES	YES
COMPONENT SIDE						
C4072	L15	4 / 5	.1uF	NONE	YES	YES
C4072	L15	8 / 5	.1uF	NONE	YES	YES
C4072	F3	4 / 5	.1uF	NONE	YES	YES
C4072	F3	8 / 5	.1uF	NONE	YES	YES
C56	ADD .1uF across 10uF			NONE	YES	YES

COMP	SECTION	VALUE WAS	VALUE NOW IS
R115	CHANNEL A STAGE 1	4K75	12K
R114	CHANNEL A STAGE 1	4K75	43K
R91	CHANNEL A STAGE 2	4K75	30K1
R90	CHANNEL A STAGE 2	4K75	18K
R29	CHANNEL B STAGE 1	4K75	12K
R42	CHANNEL B STAGE 1	4K75	43K
R31	CHANNEL B STAGE 2	4K75	30K1
R53	CHANNEL B STAGE 2	4K75	18K

VCF CONTROL MODIFICATIONS

CHANNEL A

REMOVE RN - 4

Place between 5 & 6 Discrete Imeg resistor and wire to "1st" 50K pot (see circuit)

REPLACE R43 (162ohm) with 270 ohm

ADD 30K from pin 12 (J1,2) to -Vref

ADD 220k from pin12 (J1,2) to center of "2nd" 50K pot

Mount 50K pots on J1,2

ADD 100n across R63 & R68

CHANNEL B

REMOVE RN - 2

Place between 5 & 6 Discrete Imeg resistor and wire to "1st" 50K pot (see circuit)

REPLACE R18 (162ohm) with 270 ohm

ADD 30K from pin 12 (D3,4) to -Vref

ADD 220k from pin12 (D3,4) to center of "2nd" 50K pot

Mount 50K pots on D 3,4

ADD 100n across R26 & R27

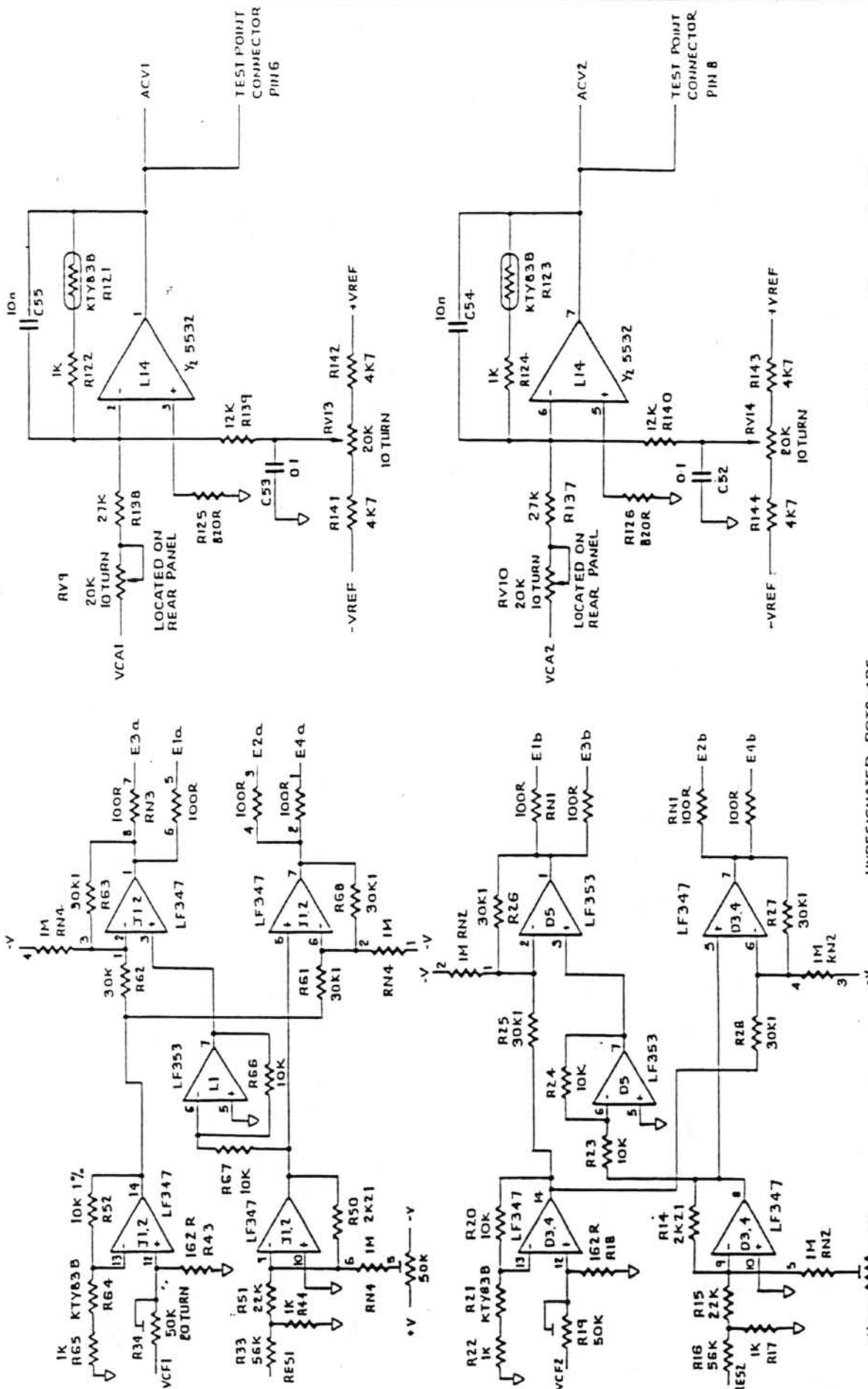

UNDESIGNATED POTS ARE MOUNTED ON TOP OF IC5, J1, J2, F1, D3, D4 & D5

Voltage Controls For VCA'S & VCFA'S

DRAWN: RH REVISION: 107.1 + 107.2

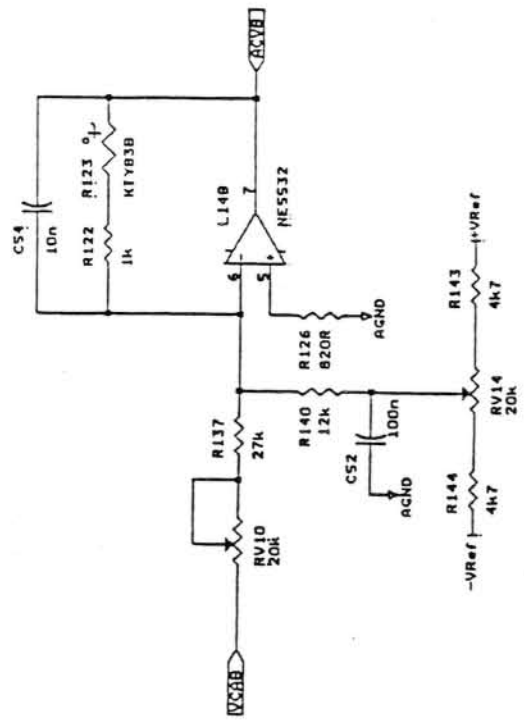
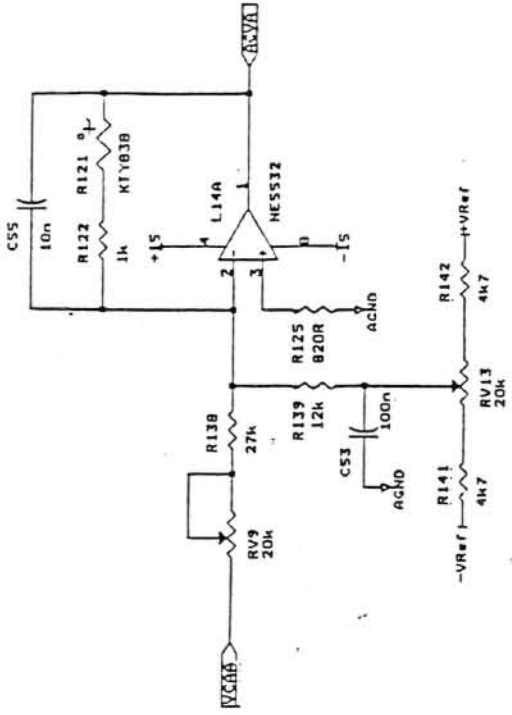

NOTE: Changes to VCF Resistor Values if this Circuit is used.

188 / 189

Fairlight ESP P/L

Title Tracking Filter & VCA Control

Size Document Number 8

REV 5

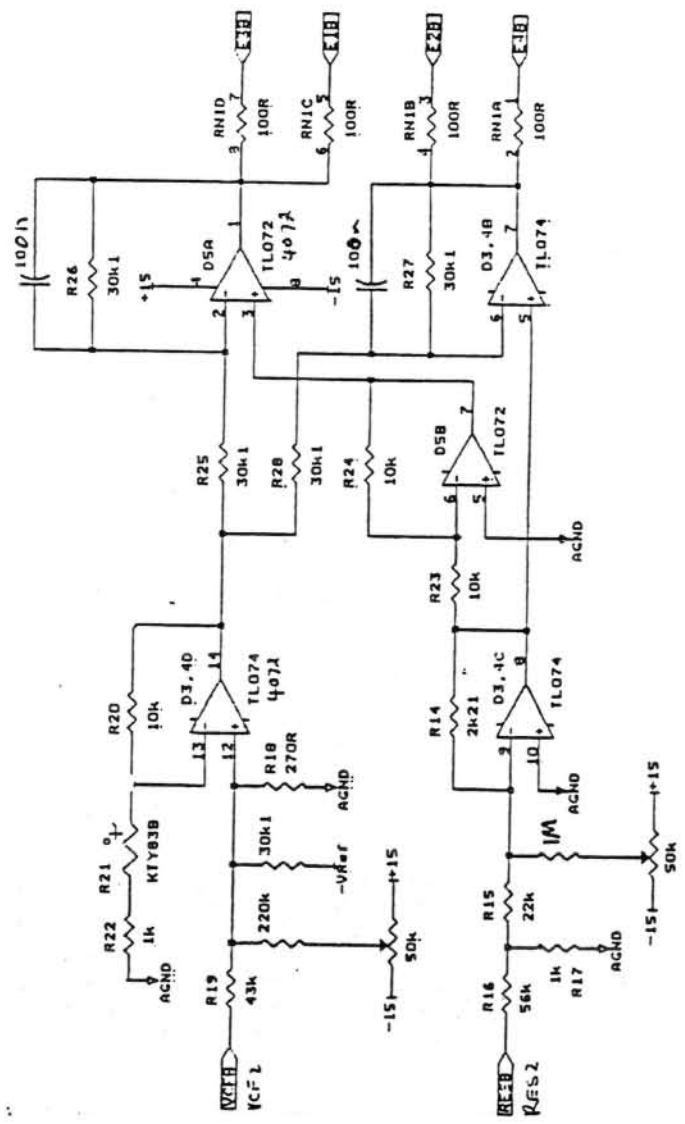
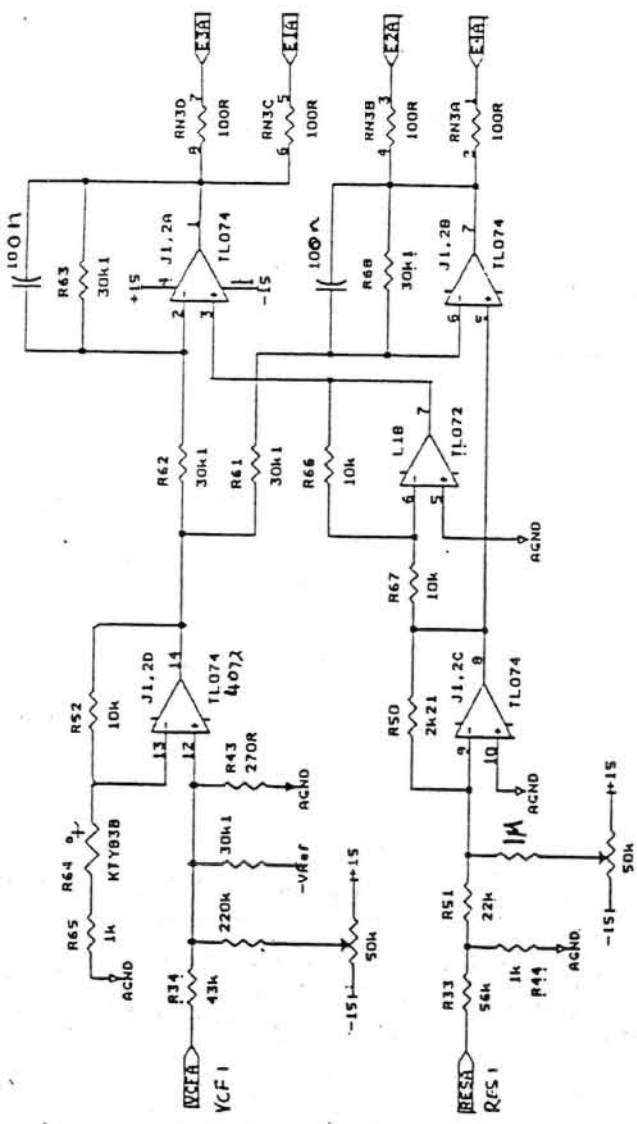

FAIRLIGHT

ASSEMBLY: CMI-331

DATE: 8 July 1992

General Information

The purpose of this document is to give the guide lines for the correct checking and modification of the Audio Output cards to the revision of **1B7.1**.

Points to check

1. There are two types of anti aliasing filters used on this card. One is a filter made by TOKO (copper can) and the other is an in house design. Component number is PAL H 1107E.

If the filter type is the in house type **check that R120 (ref M15) and R48 (ref H2) are 22K**. On boards with the TOKO filters these resistors should be **10K**. With either filter, **R109 (ref K9) and R47 (ref H1) are 10K**.

2. Check that **R74, R75, R76, R77** are either **3K65 tol 0.1% OR 2 X 5K in parallel or 2 X 4K99 in parallel or 2 X 4K75 in parallel**. These resistors **MUST** be **0.1% tolerance**.

3. Check that **C45 and C46** are installed see point 11. If wire links are installed remove them and fit 4.7uF non-polarised capacitors. Check that mod wire to C46 is installed as described in FCN 74A.

4. Check that the I.C. **L2, L5, L8** are **NE5532**

5. Check that **track on component side near pin 78 of edge connector is cut away so the shield mounting screw does not short out or use a plastic insulation washer when mounting the shield pcb**.

6. Check that **FCN 74A has been done**, and in particular that

a. **R107 and R108 (ref L9) have been removed**.

b. **R105 and R106 are 82K 1%**.

c. **C32 and C33 are 56pF**.

d. **R70, R72, R98, R100 are 100 ohm**.

e. **Wires running to IC L8 are correctly installed as described in FCN 74A**

CONT.

7. Check that wires running to the 4 trim pots mounted on IC's are not broken.

8. Install 6 X .1uF between pins on the following IC's

I.C.	Pin Numbers
J1,2	1 & 2
J1,2	6 & 7
D5	1 & 2
D3,4	6 & 7
H9,10	2 & 3
I9,10	2 & 3

9. Check quality of modification and repair if necessary.

10. Check that all XLR pop rivets are mounted flush with the front panel.

11. Change caps C26 (ref G2), C29 (ref I 4), C42 (ref K 10), C45 (ref K 11), C46 (ref K 12), C51 (ref L 16) to 4.7uF nonpolarised.

12. Label board REV 1B 7.1.



ESP

FIELD CHANGE NOTICE

Field Change
Notice No

93

PRODUCT CMI Series III

ORIGINATOR: Shane Morris

DATE: 8 / 7 / 92

ASSEMBLY No: CMI-331

DESCRIPTION: Audio Output Card

This FCN applies to rev No: 1B7

The New rev No is: 1B7.1

REASONS FOR CHANGE:

To improve low frequency response, C26, C29, C42, C45, C46, C51

To improve noise specifications; J1,2; D 5; D3,4; H9,10; I9,10.

DETAILS OF CHANGE:

Install 6 X .1uF between pins on the following IC's

I.C.	Pin Numbers
J1,2	1 & 2
J1,2	6 & 7
D5	1 & 2
D3,4	6 & 7
H9,10	2 & 3
I9,10	2 & 3

Change caps C26 (ref G2), C29 (ref I 4), C42 (ref K 10), C45 (ref K 11), C46 (ref K 12), C51 (ref L 16) to 4.7uF nonpolarised.

Label board REV 1B 7.1.

DEPT	SIGNATURE	DATE	COMMENTS
Project Manager			
Customer Service			



ESP

FIELD CHANGE NOTICE

Field Change Notice No

74A

PRODUCT CMI CVI

ORIGINATOR: Chris Alfred

DATE: 24 / 12 / 91

ASSEMBLY No: CMI-331

DESCRIPTION: Audio Output Card / Router

This FCN applies to rev No: 1B.6

The New rev No is: 1B.7

REASONS FOR CHANGE:

To increase the output level of this card & reduce crosstalk between channels.

NOTE: Once the changes detailed below are implemented, a complete Audio Cal is needed with the output level set to +24dBm.

On the Router board ESP337, the resistor networks that set the gain i.e. RP4, RP26, RP12, RP33, RP19, RP40 can be changed as follows. Resistor network 3k3 sets the level of the Router output to 16.4 dBm. Resistor network 2k7 sets the level of the Router output to 14.5 dBm .

Each resistor network is made up of 4 individual resistors & there are 6 networks per board.

The latest Rev Routers have 3k3 networks installed and 5k trim pots to fine adjust the outputs.

In Router without trim pots, the level fine adjustments can be made on the CMI 331 output cards.

DETAILS OF CHANGE:

1. Remove Ic M9 (4053)
2. Remove Resistors R107 & R108 (see overlay)
3. On wiring side - cut track going to pin 1 of the vertical filter located at D6,7 (see overlay)
4. On component side - Location H11, cut track going from the right hand lead of C40 towards the vertical filter D6,7 (see overlay)
5. On wiring side - join right hand lead of C40 to pin 1 of the vertical filter located at D6,7
6. On wiring side - (see overlay) cut track going from the top end of R54 to nearby feed through
7. On component side - cut track going underneath the overlay markings C44 & C46 at a point closest to the C of C44 and also cut the same track closest to the C of C46 (see overlay)
8. On wiring side - join the top end of R54 to the left hand side of C46 (see overlay)
9. On wiring side - join Ic M9 (4053) pin 4 to Ic L8 (5532) pin 6
10. On wiring side - join Ic M9 (4053) pin 14 to Ic L8 (5532) pin 2
11. Change capacitors C32 & C33 located at L8 to 56pF
12. Change resistors R105 & R106 to 82k (see overlay)
13. Change resistors R70, R72, R98 & R100 to 100R (see overlay)
14. Mark the boards rev 1B.7

DEPT	SIGNATURE	DATE	COMMENTS
Project Manager			
Customer Service			



ESP

FIELD CHANGE NOTICE

Field Change
Notice No

74

PRODUCT

CMI

CVI

ORIGINATOR:

Chris Alfred

DATE:

29 / 5 / 91

ASSEMBLY No:

CMI-331

DESCRIPTION:

Audio Output Card

This FCN applies to rev No:

1B.6

The New rev No is:

1B.7

REASONS FOR CHANGE:

To increase the output level of this card & Improve crosstalk between channels.

DETAILS OF CHANGE:

1. Remove Ic M9 (4053)
2. Remove Resistors R107 & R108 (see overlay)
3. On wiring side - cut track going to pin 1 of the vertical filter located at D6,7 (see overlay)
4. On component side - Location H11, cut track going from the right hand lead of C40 towards the vertical filter D6,7 (see overlay)
5. On wiring side - join right hand lead of C40 to pin 1 of the vertical filter located at D6,7
6. On wiring side - (see overlay) cut track going from the top end of R54 to nearby feed through
7. On component side - cut track going underneath the overlay markings C44 & C46 at a point closest to the C of C44 and also cut the same track closest to the C of C46 (see overlay)
8. On wiring side - join the top end of R54 to the left hand side of C46 (see overlay)
9. On wiring side - join Ic M9 (4053) pin 4 to Ic L8 (5532) pin 6
10. On wiring side - join Ic M9 (4053) pin 14 to Ic L8 (5532) pin 2
11. Change capacitors C32 & C33 located at L8 to 56pF
12. Change resistors R105 & R106 to 82k (see overlay)
13. Change resistors R70, R72, R98 & R100 to 100R (see overlay)
14. Change capacitors C45 & C46 located at K11 to 4.7uF bipolar

DEPT	SIGNATURE	DATE	COMMENTS
Project Manager	<i>Chris Alfred</i>	22/8/91	
Customer Service	<i>M. Peeling</i>	22-8-91	



FIELD CHANGE NOTICE

DATE 1 / 2 / 92

NUMBER 66

ORIGINATOR Bill Hanger

PRODUCT: CMI / MFX

ASSEMBLY No. CMI-331 DESCRIPTION Audio out put card

This FCN applies to REV No: ALL

The New REV No is: add 0.1

REASON FOR CHANGE:

This FCN should only be done when a Router Card is being installed.

To reduce switching clicks, the output level of the Audio output card is increased to 16dB nominal.

The cards will require partial recalibration.

DETAILS OF CHANGE:

- 1) Resistors R105 and R106 change to 12k 1%
- 2) Use the level adjustment pots to increase the level to +16 dB.
- 3) Adjust minimum distortion level as detailed in the calibration procedure.

At this stage the output levels of the audio are identical. To allow for component tolerances on the router we will now fine tune these levels.

- 4) Under CMI create a voice with a NPH of 16
- 5) Go to FX page (ESC F3), set LEVEL (dB) and LEVEL 2 to 0
- 6) Go to SC page and hit F6 which will display the router status.
- 7) Play any note around middle C and monitor output 1. Adjust to +4dB out
- 8) Play the note again & confirm that channel card 2 is playing by observing the LEDs on the channel card. Now adjust the audio o/p card until this level is +4 dB.
- 9) Repeat for all.

ORIGINATOR:

DATE:

SERVICE MANAGER:

DATE:

Terminology

WP: Waveform Processor
WRAM: Waveform Ram (2M-14Mbytes)
CC: Channel Card
CCP: Channel Card Processor
CSC: Channel support Card
CPU: Dual 6809 processor system running OS/9
AM: Audio Module CMI331
AMM: Audio Mixer Module CMI334
AR: Audio Rack Assembly
AMB: Audio MotherBoard CMI335
DAC: Digital to Analog Convertor
WB: Waveform Bus
VCF: Voltage Controlled Filter

Active low signals are preceded by a '/' character.

Introduction

The Audio Module (AM) contains the analog circuitry necessary to filter and control the output from a 16 bit Digital to Analog Convertor (DAC). A typical CMI system contains eight AMs which are located in the rear Audio Rack (AR) slots two through nine. (slots are numbered in Chinese fashion, from right to left looking at the rear of the CMI).

The AM is supplied with all inputs by the Audio MotherBoard (AMB). These include:

- Power, which is derived from the CMI310;
- Data, which is supplied in differential form from the Channel Support Card (CSC);
- Clocks, these are supplied originally from the appropriate Channel Card (CC);
- Control Voltages, these also are supplied by the CC;
- Control Signals, these are NON-essential controls which may be supplied from the Audio Mixer Module (AMM), see later discussion of control functions for further details.

The only output from the AM is the two audio channels which appear on the rear XLRs and also go to the AMM via the AMB.

Audio Module Structure

(refer Audio Module Block Diagram)

As can be seen from the above referenced drawing, sixteen bit data is buffered and latched (by DCLK) on the AM then clocked (by PCLK) into the DAC. The analog output is then fed through an 11th order 20 kHz low pass filter to remove all traces of sampling noise and aliasing. Note that this filter is ineffective for playback rates below approximately 44 kHz, ie when samples are played down pitch. To provide this function for down pitch sounds a fourth order tracking filter is used. The tracking filter also allows some sound effects to be created by altering the cut-off frequency as well as the resonance or 'Q' of the filter. From the tracking filter the audio signal is passed through a voltage controlled amplifier which allows control of the output level, attack and decay of the sound. Finally the signal passes through a switched mixer (under control of the AMM) which is capable of mixing the two audio signals present on the AM to form

VCA gain controls are calibrated by RV9 and 10 while RV13 and 14 provide calibration for the +4dBm output level. R121 and R123 are thermistors to compensate for thermal drift of the VCAs. C52 through C55 limit bandwidth and assist with stability as the op amp has a gain of less than 1.

VCF control for the 'A' half of the AM centres around ICs J1,2 and L1. Working backwards, J1,2 pins 1 and 7 supply the control voltages for the four VCAs within the VCF and RN3 (100 ohm) provides isolation between VCA control inputs. R62 and R63 give this stage (pins 1,2 & 3) a gain of 1 while RN4 (1Mcg ohm pins 3 and 4) gives a dc offset of approx 460mV so that the filter is set to 20Hz 3dB point with a control voltage of 0V applied.

IC J1,2 (pins 12,13 & 14) has a gain of 6 with R64 giving thermal compensation of cut-off frequency. R34 and 43 divide the 0 to 10volt control down to approx 0 to 60 mV.

IC J1,2 (pins 8,9 & 10) is used to cause a variation in control voltage between the 1st and 2nd VCA in each filter stage. This causes an increase in resonance while not changing the passband cut-off point.

The 50k ohm trimmer is used to set the resonance so that flat response is obtained when the control input is set to 0V.

Operation of both halves of the control circuits is identical.

Digital to Analog Converter and Voltage Controlled Amplifier (refer schematic CMI331-03 and 04)

Starting from the left, the sixteen bit data is latched from the WB by DCLK into the first set of latches, PCLK clocks the data into the DAC through the second set of latches, the Two current outputs are added and fed via a buffer stage to the 11th order elliptical filter which attenuates unwanted sampling noise to -85dB.

Data is clocked into the first stage of latches (ICs D13,14 & D15,17) by /DCLK through IC A5,6. The pitch clock (/PCLK) (IC A5,6) clocks the data into the second latch stage (ICs E13,14 and E15,17).

The DAC converts this data into 2 current outputs which are converted by IC G12,13 into a voltage of 14Vpeak to peak max at pin 1 of IC G12,13. IC I12 reduces this signal and provides some filtering before feeding into the 11th order elliptical filter.

The VCA is a current mode device and should be fed with a signal with 0 dc offset via C45 and R111. Distortion is trimmed with RV12.

The B Half of the circuitry is identical in operation to that just described.

Voltage Controlled Filter (refer schematic CMI331-05, 06, 07, 08)

The VCF is a state variable type utilising two voltage controlled integrators per stage with feedback. Two stages are used to give a 4th order characteristic. One stage only will be described as all four stages are identical.

EDGE CONNECTOR

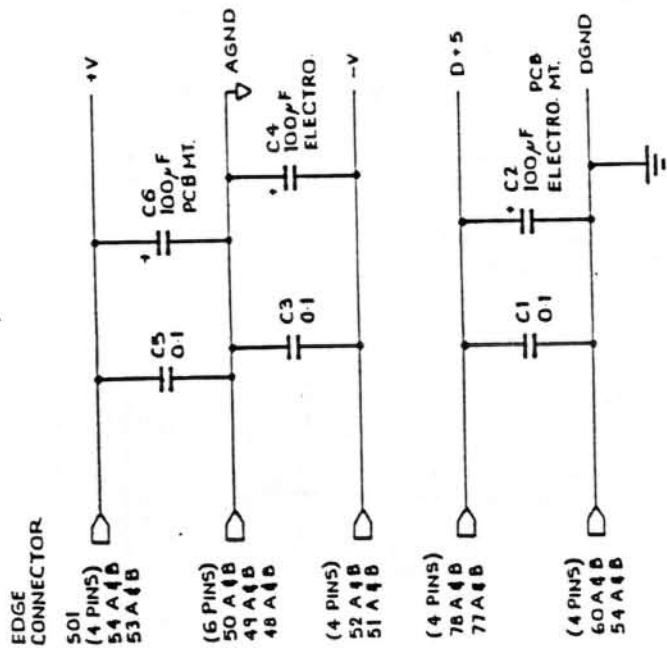
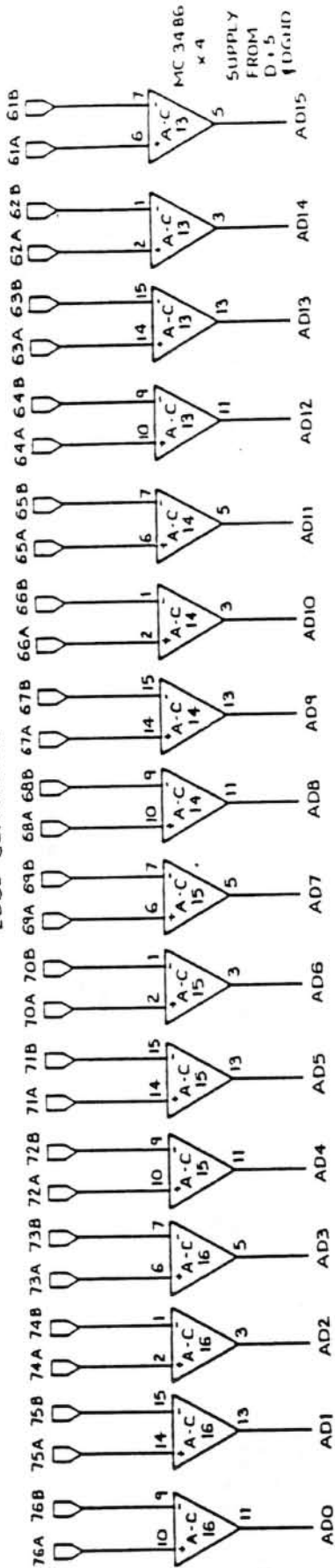

AUDIO CARD CAGE - 3.2.7

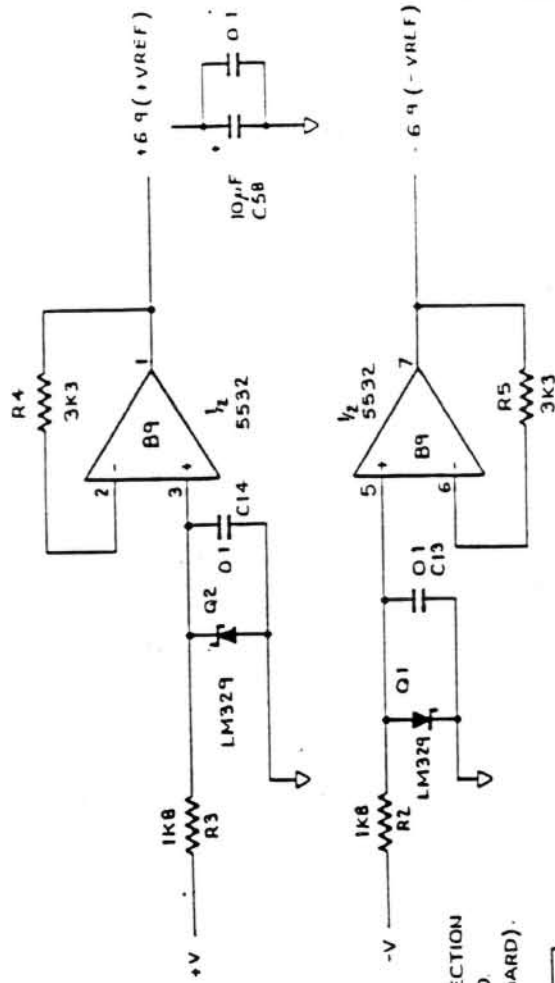

AGND & DGND HAVE NO CONNECTION ON THIS BOARD (SEE MOTHER BOARD).

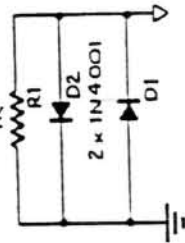

Data Buffers, Power Supplies and Voltage References

DRAWN: RH REVISION: 1B1

fairlight

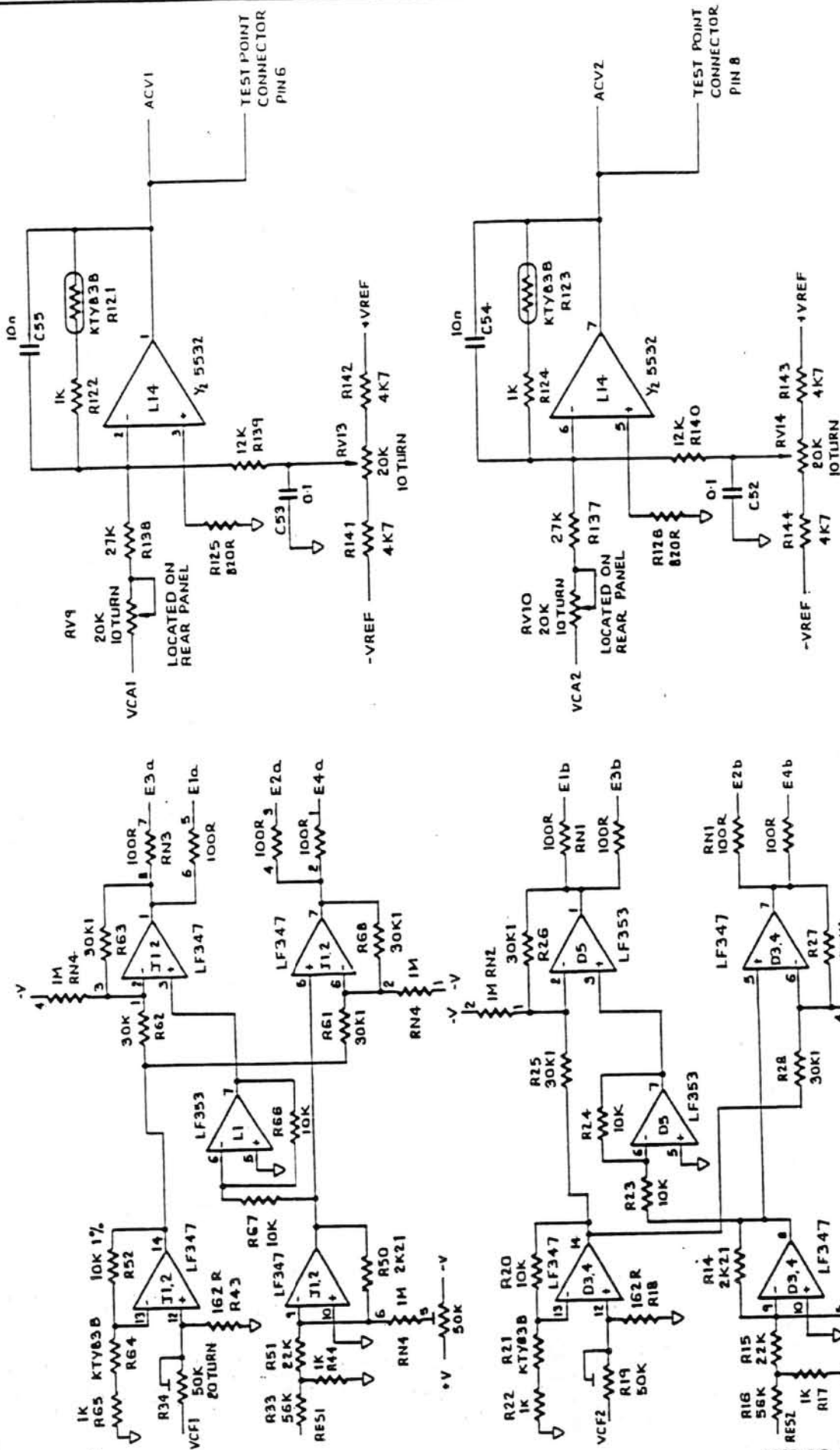

Voltage Controls For
VCA'S & VCF'S

DRAWN: RII REVISION: 1B.1

UNDESIGNATED POTS ARE
MOUNTED ON TOP OF
IC5 J1.2, F1, D3, D4 &
D5

Latches, DAC, 20KHZ LPF, VCA
Channel 2 (B)

DRAWN: RII REVISION: 1B.1

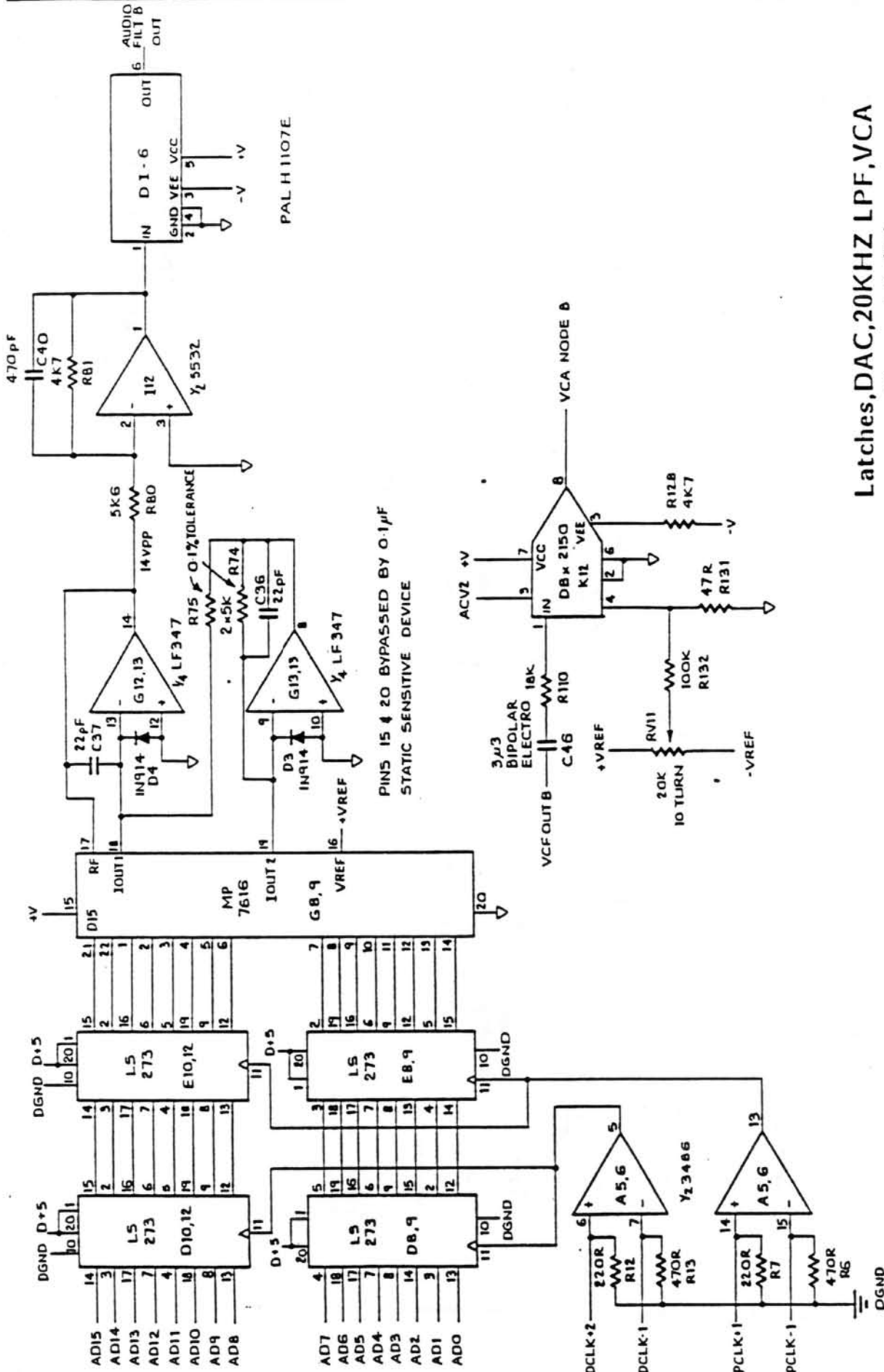

PINS 15 & 20 BYPASSED BY 0.1µF
STATIC SENSITIVE DEVICE

Voltage Controlled Filter
 Channel A Stage 2
 DRAWN: RII REVISION: IB.1

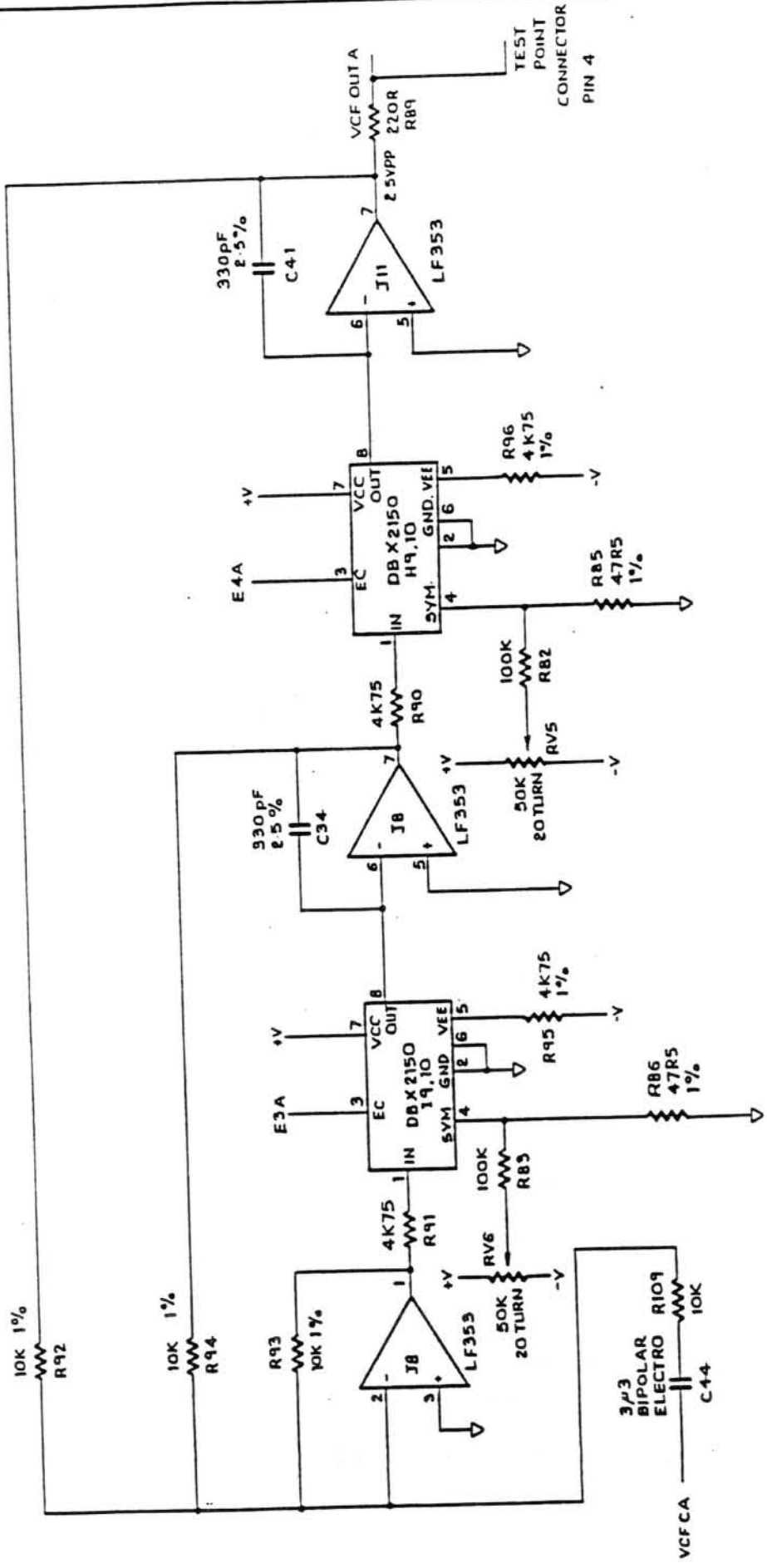

Fairlight

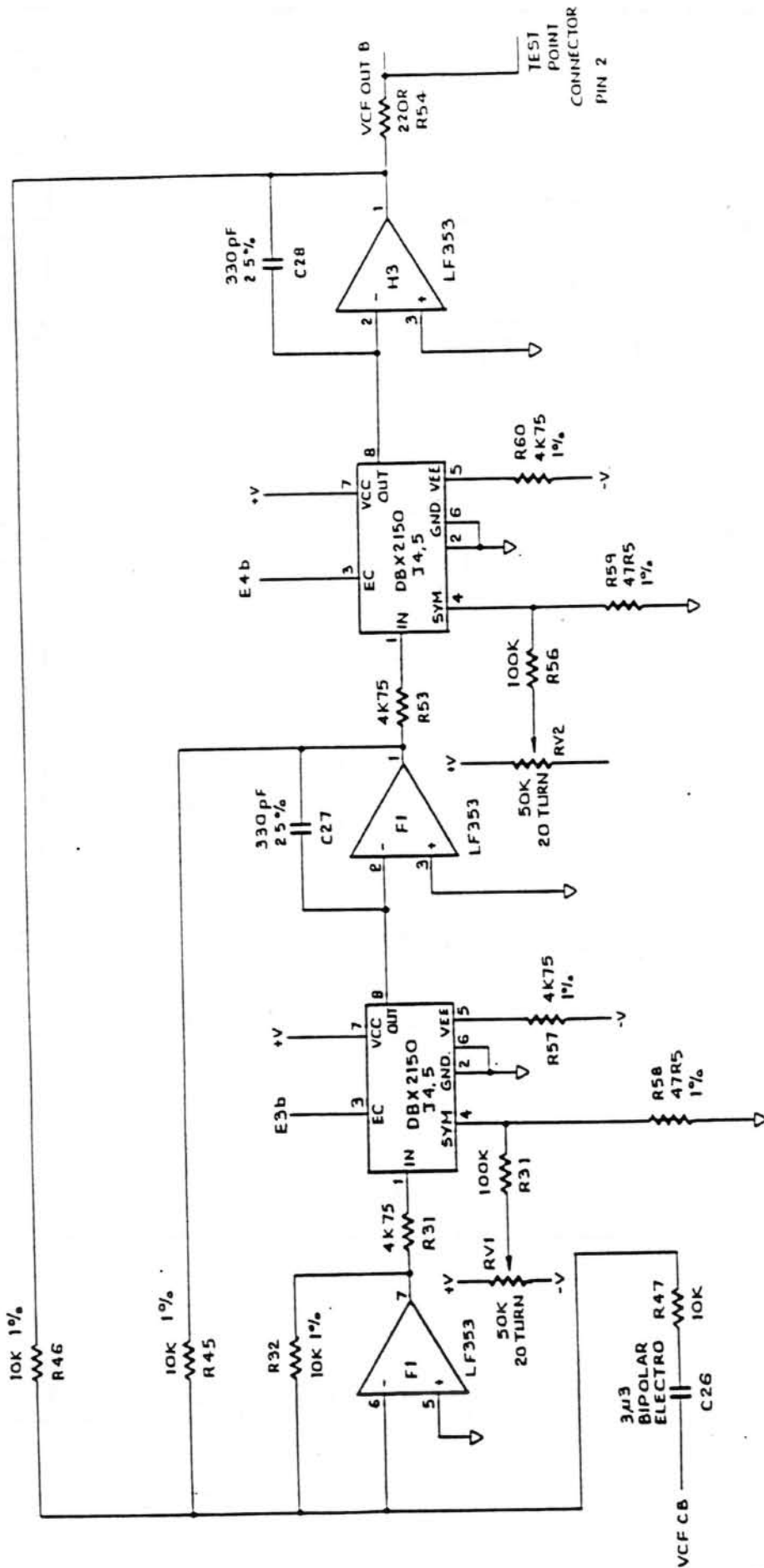

Voltage Controlled Filter
Channel B Stage 2

DRAWN: RH REVISION: 001

twilight

AUDIO CARD LAYOUT FOR CMI-331 LP TO REV 1B7.2

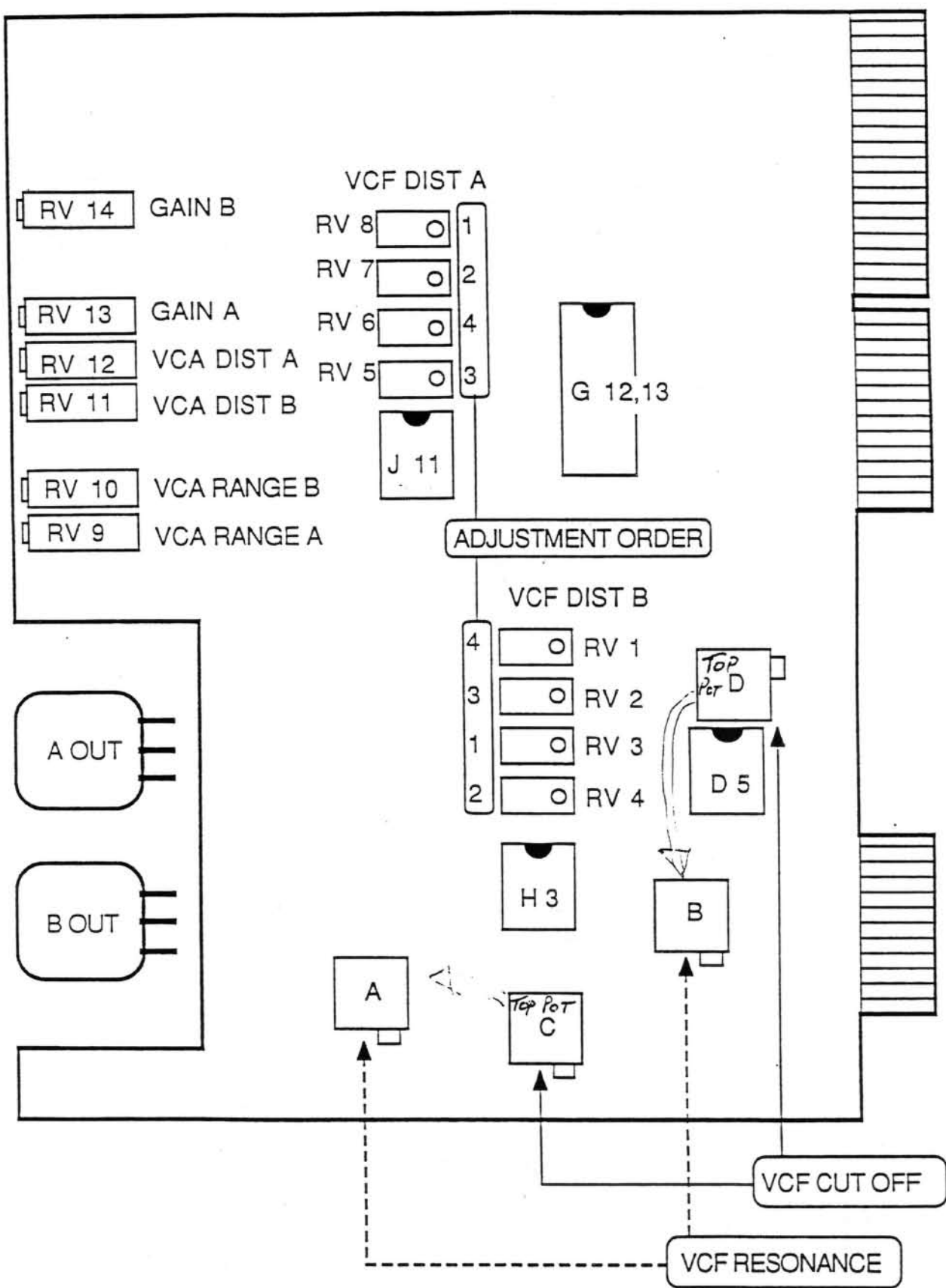

OUTPUT BOARD CALIBRATION
FOR REVISION 1B7.2 CARDS

1. From shell type "kstart SPACE -c SPACE /k2/kmondiag" <return>
OR "wsdiag" <return>
2. Type "a" for audio calibration programme <return>
For each card Leave 5 mins. for temperature to stabilise.
3. Using multimeter : +ve lead connected to junction of R68 & pin 7 J1,2B (bottom R68) and -ve lead connected to junction of R63 & pin 1 J1,2A(left of R63). Adjust for 20 to 25 millivolts on bottom pot "A".
4. Using multimeter : +ve lead on 0v (left of R43) and -ve lead connected to junction of R63 & pin 1 J1,2A(left of R63). Adjust for -72 millivolts on top pot "C".
5. Using multimeter : +ve lead connected to junction of R27 & pin 7 J3,4B (top of R27) and -ve lead connected to junction of R26 & pin 1 D5A (left of R26). Adjust for 20 to 25 millivolts on bottom pot "B".
6. Using multimeter : +ve lead on 0v (left of R43) and -ve lead connected to junction of R26 & pin 1 D5A (left of R26). Adjust for -72 millivolts on top pot "D".
7. Using multimeter : -ve lead on 0v and +ve lead on centre of RV8, adjust for a reading of zero millivolts (+ / - 10mV). Repeat for RV7, RV6, RV5, RV4, RV3, RV2, RV1.

Note: The Neutrik has a 20 Hz to 20kHz filter if test device has a 30kHz filter some noise and distortion measurements may be higher. Do not use any filter when doing frequency response tests.

THE FOLLOWING SHOULD BE FIRST DONE READING A OUT ONLY.

8. Select "Step 1" of audiocal, adjust output level as seen on "Neutrik" to 25.0 dBu, for CHA using the gain pot RV13 (*RV14 for B out*).
Note: B channel in *italics* .
9. Select "Step 2" of audiocal you should see an output of typically 13.0 dBu, press "LEVEL REL" then "SET REF" on "NEUTRIK".
Displays 0.00 dBr.
10. Select "Step 3". Adjust top pot "C" ("*D*") to peak reading, typically 8.8 dBr (21.8 dBu).
11. Select "Step 4". Adjust bottom pot "A" ("*B*") for a reading of -2dBr (11.0 dBu).
12. Recheck "10". Continue to recheck "10" and "11" until correct levels have been achieved.
13. Select "Step 5" adjust top pot "C" ("*D*") for -20 dBr (-7.0 dBu).
14. Select "Step 6" adjust bottom pot "A" ("*B*") for 1dBr (14.0 dBu)
15. Select CHB output. Return "NEUTRIK" to dBu reading and follow procedure from points 8 to 14 for channel B. Note B channel pots in *italics* .

IMPORTANT: dBr and dBu are very different and levels must be checked with their correct reference. Use dBu in () if test device does not have a relative set function.