

16. FOR CHANNEL A ONLY

Select "Step 7", select the "THD" function using dB as measurement unit and the 20Hz to 20kHz filter OFF on the "NEUTRIK". Set the "NEUTRIK" output for 15kHz and a level of 19dBu. Using the modified test clip inject the output of the "NEUTRIK" into pin 2 of IC G12,13 via the 4K7 or use TPA on S & H board. Slightly adjust the output of the "NEUTRIK" for an output reading of +19dBu out of XLR.

(Test clip has a 4K7 resistor connected to pin 2 for channel A and to pin 13 for channel B)

17. Connect input of "NEUTRIK" to pin 1 J11, and at R102 analogue ground. Adjust pot RV7 & RV8 for maximum -ve reading in THD mode, adjust the pot with maximum effect first. The reading should be typically -78dB for 1B8, 1B9 or -70dB for 1B7.2, 1B10, 1B11.

18. Connect input of "NEUTRIK" to pin 7 J11, and at R102 analogue ground. Adjust pot RV6 & RV5 for maximum -ve reading in THD mode. Adjust the pot with maximum effect first. The reading should be typically -74 dB for 1B8, 1B9 or -68dB for 1B7.2, 1B10, 1B11 or better.

19. Set 2kHz -> 20kHz sweep and observe output from filter. Select measurement unit to THD+N %

THD+N should start at .01% and move to .035% at 8kHz returning to .01% at 18kHz. If a sweep function is not available do spot checks of frequencies between 2kHz and 18kHz.

20. FOR CHANNEL B ONLY

Select "Step 7", select the "THD" function using dB as measurement unit and the (20Hz to 20kHz) filter OFF on the "NEUTRIK". Set the "NEUTRIK" output for 15kHz and a level of 19dBu. Using the modified test clip inject the output of the "NEUTRIK" into pin 13 of IC G12,13 via the 4K7 or use TPB on the S&H board. Slightly adjust the output of the "NEUTRIK" for an output of +19dBu out of XLR.

(Test clip has a 4K7 resistor connected to pin 2 for channel A and to pin 13 for channel B)

21. Connect input of "NEUTRIK" to pin 7 H3, and at R102 analogue ground. Adjust pot RV3 & RV4 for maximum -ve reading in THD mode, adjust the pot with maximum effect first. The reading should be typically -78dB for 1B8, 1B9 or -70dB for 1B7.2, 1B10, 1B11..
22. Connect input of "NEUTRIK" to pin 1 H3, and at R102 analogue ground. Adjust pot RV1 & RV2 for maximum -ve reading in THD mode. Adjust the pot with maximum effect first. The reading should be typically -74 dB for 1B8, 1B9 or -68dB for 1B7.2, 1B10, 1B11 or better.
23. Set 2kHz -> 20kHz sweep and observe output from filter. Select measurement unit to THD+N %  
THD+N should start at .01% and move to .035% at 8kHz returning to .01% at 18kHz. If a sweep function is not available do spot checks of frequencies between 2kHz and 18kHz.
24. Disconnect test clip.
25. Select "Step 8" connect output XLR's to "NEUTRIK" inputs, check for +25.0 dBu at the XLR outputs, adjust RV12 on CHA out for minimum THD reading. Adjust RV11 on CHB for minimum THD reading, i.e., max -ve reading at 1 kHz. (.025% THD+N at 1kHz)
27. Select "Step 8", Select LEVEL check +25dBu reading on channel A out and B out.
28. Select "REL LEVEL" on "NEUTRIK" then "SET REF" Meter will read 0.00 dBr (25.0 dBu).
29. Select "Step 9", Adjust RV9 on Channel A to maximum negative reading, typically -90dBr, then readjust to -75dBr (-50dBu). Repeat procedure on Channel B using RV10.
30. Select "Step 10", observe that reading is -88 dBr (-65dbu) or better.  
**CHECK BOTH CHANNEL A AND CHANNEL B.**

31. Select "Step 11", observe reading of 0.00 dBr (25.0 dBu). CHECK BOTH CHANNEL A AND CHANNEL B.
32. Select "Step 12", observe a reading of -75dBr (-57.0 dBu) or better for channel A and channel B.
33. Select "Step 13", observe a reading of 0.00dBr (25.0 dBu) for both channel A and channel B.
34. Select "Step 14", observe a reading of -95dBr (-73dBu) or better, for channel A and for channel B.
35. Select "Step 15", Deselect 20Hz to 20KHz filter. Press "set" key on to break from Audiocal type "r SPACE 3", then press "return", then type "S SPACE 48000" and press "return". Type "g" then "return", you are now running "Step 15" with a sample rate of "48K" and resonance of "3". Use up / down arrows on keyboard to get to a frequency of "1 kHz". Zero the display using "Level Rel" and "SET REF" then step from 20 Hz to 20 kHz using up key and check response on "Level" setting.  
-1.5dBr at 20Hz, 0dBr at 1kHz, -2.5dBr at 20kHz + / - 2.0dB
36. To carry out distortion checks for OUTPUT A and OUTPUT B at frequencies between 20Hz to 20kHz. Return Audiocal to step 1 by typing "q" return and then "a" return. Select filter and use the arrow up and arrow down keys to change the frequency.

Typical Figures are:

Full level			Step 16	output level +14dB
FREQ	THD+N	-dB	THD+N	-dB
20Hz	.02%	-70	.045%	-65
50Hz	.02%	-70	.040%	-65
100Hz	.02%	-70	.040%	-65
200Hz	.02%	-70	.045%	-65
500Hz	.02%	-70	.045%	-65
1000Hz	.03%	-70	.045%	-65
2000Hz	.04%	-65	.060%	-63
5000Hz	.105%	-60	.095%	-60
10 K	.250%			
18 K	.350%			

FOR BOARDS  
WITH S&H... PRESS 'SET' THEN TYPE "A 55" ↵  
DIST. SHOULD BE < 5% (AT 1K)

10000Hz	.250%	-55	.180%	-54
18000Hz	.350%	-50	.350	-50

See test procedure for Sample and Hold boards.

AUDIO CARD LAYOUT FOR CMI-331 REV 1B.8, 1B9 and 1B10

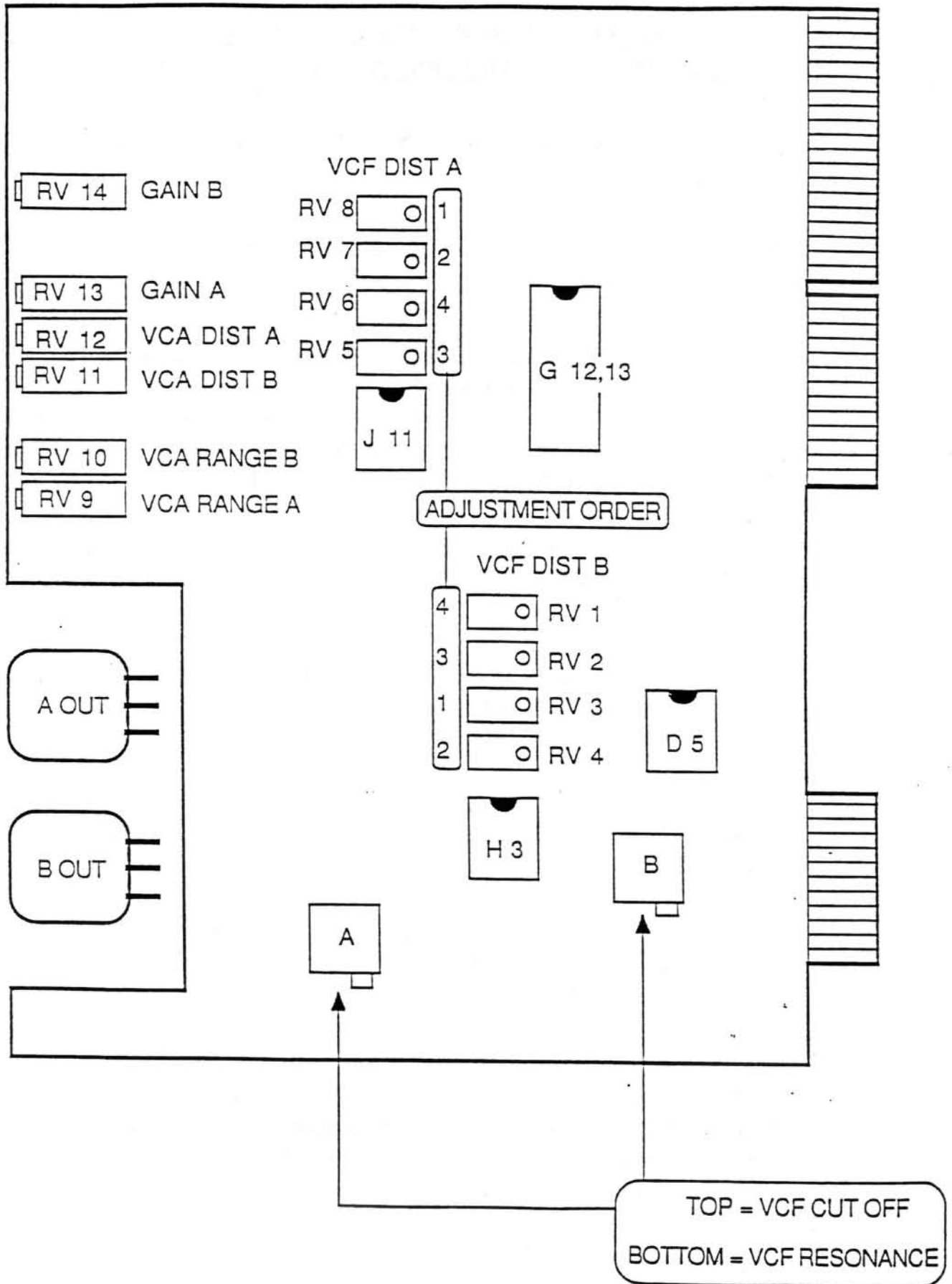

OUTPUT BOARD CALLIBRATION  
FOR REVISION 1B8,1B9,1B10 & 1B11 CARDS

1. From shell type "kstart SPACE -c SPACE /k2/kmondiag" <return>  
OR "wsdiag" <return>
2. Type "a" for audio calibration programme <return>  
For each card Leave 5 mins. for temperature to stabilise.

The following points 3 through to 7 are for 1B8, 1B9,1B10 and 1B11 revisions. See Document at the end of this procedure for any variations.

3. Using multimeter : +ve lead connected to junction of R68 & pin 7 J1,2B (bottom of R68) and -ve lead connected to junction of R63 & pin 1 J1,2A (left of R68). Adjust for zero millivolts on bottom pot "A".
4. Using multimeter : +ve lead on 0v (left of R43) and -ve lead connected to junction of R63 & pin 1 J1,2A (left of R63). Adjust for zero millivolts on top pot "A".
5. Using multimeter : +ve lead connected to junction of R27 & pin 7 J3,4B (top of R27) and -ve lead connected to junction of R26 & pin 1 D5A (left of R26). Adjust for zero millivolts on bottom pot "B".
6. Using multimeter : +ve lead on 0v (left of R43) and -ve lead connected to junction of R26 & pin 1 D5A (left of R26). Adjust for zero millivolts on top pot "B".
7. Using multimeter : -ve lead on 0v and +ve lead on centre of RV8, adjust for a reading of zero millivolts ( + / - 10mV ). Repeat for RV7, RV6, RV5, RV4, RV3, RV2, RV1.

Note: The Neutrik has a 20 Hz to 20kHz filter if test device has a 30kHz filter some noise and distortion measurements may be higher. Do not use any filter when doing frequency response tests.

THE FOLLOWING SHOULD BE FIRST DONE READING A OUT ONLY.

8. Select "Step 1" of audiocal, adjust output level as seen on "Neutrik" to 25.0 dBu, for CHA using the gain pot RV13 (*RV14 for B out*).  
Note: B channel in *italics* .
9. Select "Step 2" of audiocal you should see an output of typically 13.0 dBu, press "LEVEL REL" then "SET REF" on "NEUTRIK".  
Displays 0.00 dBr.
10. Select "Step 3". Adjust top pot "C" ("*D*") to peak reading, typically 8.8 dBr (21.8 dBu).
11. Select "Step 4". Adjust bottom pot "A" ("*B*") for a reading of -2dBr (11.0 dBu).
12. Recheck "10". Continue to recheck "10" and "11" until correct levels have been achieved.
13. Select "Step 5" adjust top pot "C" ("*D*") for -20 dBr (-7.0 dBu).
14. Select "Step 6" adjust bottom pot "A" ("*B*") for 1dBr (14.0 dBu)
15. Select CHB output. Return "NEUTRIK" to dBu reading and follow procedure from points 8 to 14 for channel B. Note B channel pots in *italics* .

IMPORTANT: dBr and dBu are very different and levels must be checked with their correct reference. Use dBu in ( ) if test device does not have a relative set function.

16. FOR CHANNEL A ONLY

Select "Step 7", select the "THD" function using dB as measurement unit and the 20Hz to 20kHz filter OFF on the "NEUTRIK". Set the "NEUTRIK" output for 15kHz and a level of 19dBu. Using the modified test clip inject the output of the "NEUTRIK" into pin 2 of IC G12,13 via the 4K7 or use TPA on S & H board. Slightly adjust the output of the "NEUTRIK" for an output reading of +19dBu out of XLR.

(Test clip has a 4K7 resistor connected to pin 2 for channel A and to pin 13 for channel B)

17. Connect input of "NEUTRIK" to pin 1 J11, and at R102 analogue ground. Adjust pot RV7 & RV8 for maximum -ve reading in THD mode, adjust the pot with maximum effect first. The reading should be typically -78dB for 1B8, 1B9 or -70dB for 1B7.2, 1B10, 1B11.

18. Connect input of "NEUTRIK" to pin 7 J11, and at R102 analogue ground. Adjust pot RV6 & RV5 for maximum -ve reading in THD mode. Adjust the pot with maximum effect first. The reading should be typically -74 dB for 1B8, 1B9 or -68dB for 1B7.2, 1B10, 1B11 or better.

19. Set 2kHz -> 20kHz sweep and observe output from filter. Select measurement unit to THD+N %  
THD+N should start at .01% and move to .035% at 8kHz returning to .01% at 18kHz. If a sweep function is not available do spot checks of frequencies between 2kHz and 18kHz.

20. FOR CHANNEL B ONLY

Select "Step 7", select the "THD" function using dB as measurement unit and the (20Hz to 20kHz) filter OFF on the "NEUTRIK". Set the "NEUTRIK" output for 15kHz and a level of 19dBu. Using the modified test clip inject the output of the "NEUTRIK" into pin 13 of IC G12,13 via the 4K7 or use TPB on the S&H board. Slightly adjust the output of the "NEUTRIK" for an output of +19dBu out of XLR.

(Test clip has a 4K7 resistor connected to pin 2 for channel A and to pin 13 for channel B )

21. Connect input of "NEUTRIK" to pin 7 H3, and at R102 analogue ground. Adjust pot RV3 & RV4 for maximum -ve reading in THD mode, adjust the pot with maximum effect first. The reading should be typically -78dB for 1B8, 1B9 or -70dB for 1B7.2, 1B10, 1B11..
22. Connect input of "NEUTRIK" to pin 1 H3, and at R102 analogue ground. Adjust pot RV1 & RV2 for maximum -ve reading in THD mode. Adjust the pot with maximum effect first. The reading should be typically -74 dB for 1B8, 1B9 or -68dB for 1B7.2, 1B10, 1B11 or better.
23. Set 2kHz -> 20kHz sweep and observe output from filter. Select measurement unit to THD+N %  
THD+N should start at .01% and move to .035% at 8kHz returning to .01% at 18kHz. If a sweep function is not available do spot checks of frequencies between 2kHz and 18kHz.
24. Disconnect test clip.
25. Select "Step 8" connect output XLR's to "NEUTRIK" inputs, check for +25.0 dBu at the XLR outputs, adjust RV12 on CHA out for minimum THD reading. Adjust RV11 on CHB for minimum THD reading, i.e., max -ve reading at 1 kHz. (.025% THD+N at 1kHz)
27. Select "Step 8", Select LEVEL check +25dBu reading on channel A out and B out.
28. Select "REL LEVEL" on "NEUTRIK" then "SET REF" Meter will read 0.00 dBr (25.0 dBu).
29. Select "Step 9", Adjust RV9 on Channel A to maximum negative reading, typically -90dBr, then readjust to -75dBr (-50dBu). Repeat procedure on Channel B using RV10.
30. Select "Step 10", observe that reading is -88 dBr (-65dbu) or better. CHECK BOTH CHANNEL A AND CHANNEL B.

31. Select "Step 11", observe reading of 0.00 dBr (25.0 dBu). CHECK BOTH CHANNEL A AND CHANNEL B.
32. Select "Step 12", observe a reading of -75dBr (-57.0 dBu) or better for channel A and channel B.
33. Select "Step 13", observe a reading of 0.00dBr (25.0 dBu) for both channel A and channel B.
34. Select "Step 14", observe a reading of -95dBr (-73dBu) or better, for channel A and for channel B.
35. Select "Step 15", Deselect 20Hz to 20KHz filter. Press "set" key on to break from Audiocal type "r SPACE 3", then press "return", then type "S SPACE 48000" and press "return". Type "g" then "return", you are now running "Step 15" with a sample rate of "48K" and resonance of "3". Use up / down arrows on keyboard to get to a frequency of "1 kHz". Zero the display using "Level Rel" and "SET REF" then step from 20 Hz to 20 kHz using up key and check response on "Level" setting.  
-1.5dBr at 20Hz, 0dBr at 1kHz, -2.5dBr at 20kHz + / - 2.0dB
36. To carry out distortion checks for OUTPUT A and OUTPUT B at frequencies between 20Hz to 20kHz. Return Audiocal to step 1 by typing "q" return and then "a" return. Select filter and use the arrow up and arrow down keys to change the frequency.

Typical Figures are:

Full level			Step 16	output level +14dB
FREQ	THD+N	-dB	THD+N	-dB
20Hz	.02%	-70	.045%	-65
50Hz	.02%	-70	.040%	-65
100Hz	.02%	-70	.040%	-65
200Hz	.02%	-70	.045%	-65
500Hz	.02%	-70	.045%	-65
1000Hz	.03%	-70	.045%	-65
2000Hz	.04%	-65	.060%	-63
5000Hz	.105%	-60	.095%	-60
10 K	.250%			
18 K	.350%			

FOR BOARDS  
WITH S & H... PRESS 'SET' THEN TYPE "A 55" ↵  
DIST. SHOULD BE ≤ 5% (AT 1K)

10000Hz	.250%	-55	.180%	-54
18000Hz	.350%	-50	.350	-50

See test procedure for Sample and Hold boards.

OUTPUT BOARD CALIBRATION  
FOR REVISION CMI-331 2.1 CARD

4/6/93

1. From shell type "kstart SPACE -c SPACE /k2/kmondiag" <return>  
OR "wsdiag" <return>
2. Type "a" for audio calibration programme <return>  
For each card Leave 5 mins. for temperature to stabilise.

Explanation of TP / JP test points.

Along the outer edge of the audio card there are 4 headers. These headers are labeled JP11, JP12, JP13, JP10.

JP11 pin 1 is TP 1, JP11 pin 2 is TP 2. The test points ( TP) follow in sequence from each JP header to the next. For example: TP9 and TP10 are pins 1 and 2 on JP12 respectively. See layout and circuit diagram sheet 8 of 8 for more detail.

3. Using multimeter : +ve lead connected to TP-2 and -ve lead connected to TP-1. Adjust for zero millivolts on VR-2.
4. Using multimeter : +ve lead on JP11 pin 10 and -ve lead connected to TP-1. Adjust for zero millivolts on VR-1.
5. Using multimeter : +ve lead connected to TP-4 and -ve lead connected to TP-3. Adjust for zero millivolts on VR-4.
6. Using multimeter : +ve lead on 0v JP<sup>11</sup> pin 10 and -ve lead connected to TP-3. Adjust for zero millivolts on VR-3.
7. Using multimeter : -ve lead on JP<sup>11</sup> pin 10 and +ve lead on TP-12 adjust VR-16 for a reading of zero millivolts ( + / - 10mV ).  
Repeat for TP-11;VR15, TP-10;VR14, TP-9;VR13, TP-8;VR12,  
TP-7;VR11, TP-6;VR10, TP-5;VR9.

Note: The Neutrik has a 20 Hz to 20kHz filter, if test device has a 30kHz filter some noise and distortion measurements may be higher. Do not use any filter when doing frequency response tests.

THE FOLLOWING SHOULD BE FIRST DONE READING A OUT ONLY.

8. Select "Step 1" of audiocal, adjust output level as seen on "Neutrik" to 25.0 dBu, for CHA using the gain pot VR6 (*VR8 for B out*).

Note: B channel in *italics* .

9. Select "Step 2" of audiocal you should see an output of typically 13.0 dBu, press "LEVEL REL" then "SET REF" on "NEUTRIK".  
Displays 0.00 dBr.

10. Select "Step 3" adjust VR1 ("*VR3*") to peak reading, typically 8.8 dBr (21.8 dBu).

11. Select "Step 4" adjust VR2 ("*VR4*") for a reading of -2dBr (11.0 dBu).

12. Recheck "10". Continue to recheck "10" and "11" until correct levels have been achieved.

13. Select "Step 5" adjust VR1 ("*VR3*") for -20 dBr (-7.0 dBu).

14. Select "Step 6" adjust VR2 ("*VR4*") for 1dBr (14.0 dBu)

15. Select CHB output. Return "NEUTRIK" to dBu reading and follow procedure from points 8 to 14 for channel B. Note B channel pots in *italics* .

IMPORTANT: dBr and dBu are very different and levels must be checked with their correct reference. Use dBu in ( ) if test device does not have a relative set function.

16. FOR CHANNEL A ONLY

Select "Step 7", select the "THD" function using dB as measurement unit and the 20Hz to 20kHz filter OFF on the "NEUTRIK". Set the "NEUTRIK" output for 15kHz and a level of 8.5dBu. inject into TP13. Slightly adjust the output of the "NEUTRIK" for an output reading of +19dBu out of XLR.

17. Connect input of "NEUTRIK" TP15, and J11 pin 10 (analogue ground). Adjust pot VR9 & VR10 for maximum -ve reading in THD mode, adjust the pot with maximum effect first. The reading should be typically -70dB.

18. Connect input of "NEUTRIK" TP17, and J11 pin 10 (analogue ground). Adjust pot VR11 & VR12 for maximum -ve reading in THD mode. Adjust the pot with maximum effect first. The reading should be typically -68dB or better.

19. Set 2kHz -> 20kHz sweep and observe output from filter. Select measurement unit to THD+N %  
THD+N should start at .01% and move to .035% at 8kHz returning to .01% at 18kHz. If a sweep function is not available do spot checks of frequencies between 2kHz and 18kHz.

20. FOR CHANNEL B ONLY

Select "Step 7", select the "THD" function using dB as measurement unit and the (20Hz to 20kHz) filter OFF on the "NEUTRIK". Set the "NEUTRIK" output for 15kHz and a level of 8.5dBu inject into TP18. Slightly adjust the output of the "NEUTRIK" for an output of +19dBu out of XLR.

21. Connect input of "NEUTRIK" to TP20 and J11 pin 10 (analogue ground). Adjust pot VR13 & VR14 for maximum -ve reading in THD mode, adjust the pot with maximum effect first. The reading should be typically -69dB.

22. Connect input of "NEUTRIK" to TP22 and J11 pin 10 (analogue ground). Adjust pot VR15 & VR16 for maximum -ve reading in THD mode. Adjust the pot with maximum effect first. The reading should be typically -69dB or better.

23. Set 2kHz -> 20kHz sweep and observe output from filter. Select measurement unit to THD+N %  
THD+N should start at .01% and move to .035% at 8kHz returning to .01% at 18kHz. If a sweep function is not available do spot checks of frequencies between 2kHz and 18kHz.
24. Disconnect test signals.
25. Select "Step 8" connect output XLR's to "NEUTRIK" inputs, check for +25dBu at the XLR outputs, adjust VR17 on CHA out for minimum THD reading. Adjust VR18 on CHB for minimum THD reading, i.e., max -ve reading at 1 kHz. (.025% THD+N at 1kHz)
27. Select "Step 8", Select LEVEL check +25dBu reading on channel A out and B out.
28. Select "REL LEVEL" on "NEUTRIK" then "SET REF" Meter will read 0.00 dBr (25.0 dBu).
29. Select "Step 9", Adjust VR5 on Channel A to maximum negative reading, typically -90dBr, then readjust to -75dBr (-50dBu). Repeat procedure on Channel B using VR7.
30. Select "Step 10", observe that reading is -88 dBr (-65dBu) or better.  
CHECK BOTH CHANNEL A AND CHANNEL B.
31. Select "Step 11", observe reading of 0.00 dBr (25.0 dBu). CHECK BOTH CHANNEL A AND CHANNEL B.
32. Select "Step 12", observe a reading of -75dBr (-57.0 dBu) or better for channel A and channel B.
33. Select "Step 13", observe a reading of 0.00dBr (25.0 dBu) for both channel A and channel B.

34. Select "Step 14", observe a reading of -92dBr (-70dBu) or better, for channel A and for channel B.
35. Select "Step 15", Deselect 20Hz to 20KHz filter. Press "set" key on to break from Audiocal type "r SPACE 3", then press "return", then type "S SPACE 48000" and press "return". Type "g" then "return", you are now running "Step 15" with a sample rate of "48K" and resonance of "3". Use up / down arrows on keyboard to get to a frequency of "1 kHz". Zero the display using "Level Rel" and "SET REF" then step from 20 Hz to 20 kHz using up key and check response on "Level" setting.
- 1.5dBr at 20Hz, 0dBr at 1kHz, -2.5dBr at 20kHz + / - 2.0dB
36. To carry out distortion checks for OUTPUT A and OUTPUT B at frequencies between 20Hz to 20kHz. Return Audiocal to step 1 by typing "q" return and then "a" return. Select filter and use the arrow up and arrow down keys to change the frequency.

Typical Figures are: Better than or equal to:

Full level			Step 16	output level +25dBu
FREQ	THD+N	-dB	THD+N	-dB
20Hz	.02%	-70	.045%	-65
50Hz	.02%	-70	.040%	-65
100Hz	.02%	-70	.040%	-65
200Hz	.02%	-70	.045%	-65
500Hz	.02%	-70	.045%	-65
1000Hz	.03%	-70	.045%	-65
2000Hz	.04%	-65	.060%	-63
5000Hz	.105%	-60	.095%	-60
10000Hz	.250%	-55	.180%	-54
18000Hz	.350%	-50	.350	-50

## ESP-399 SAMPLE & HOLD INSTALLATION INFORMATION

### Step 11.

At step 1 of audio cal press "SET" then "A" SPACE BAR then type "60" <return>. With test unit with 20Hz to 20kHz filter ON THD+N will be better than -30dB or 5% THD+N.

NOTE: This presumes the audio cal has been done per the audio card alignment procedure.





\* inputs

AD1101-AD1101-3 AD1101-AD1101-3

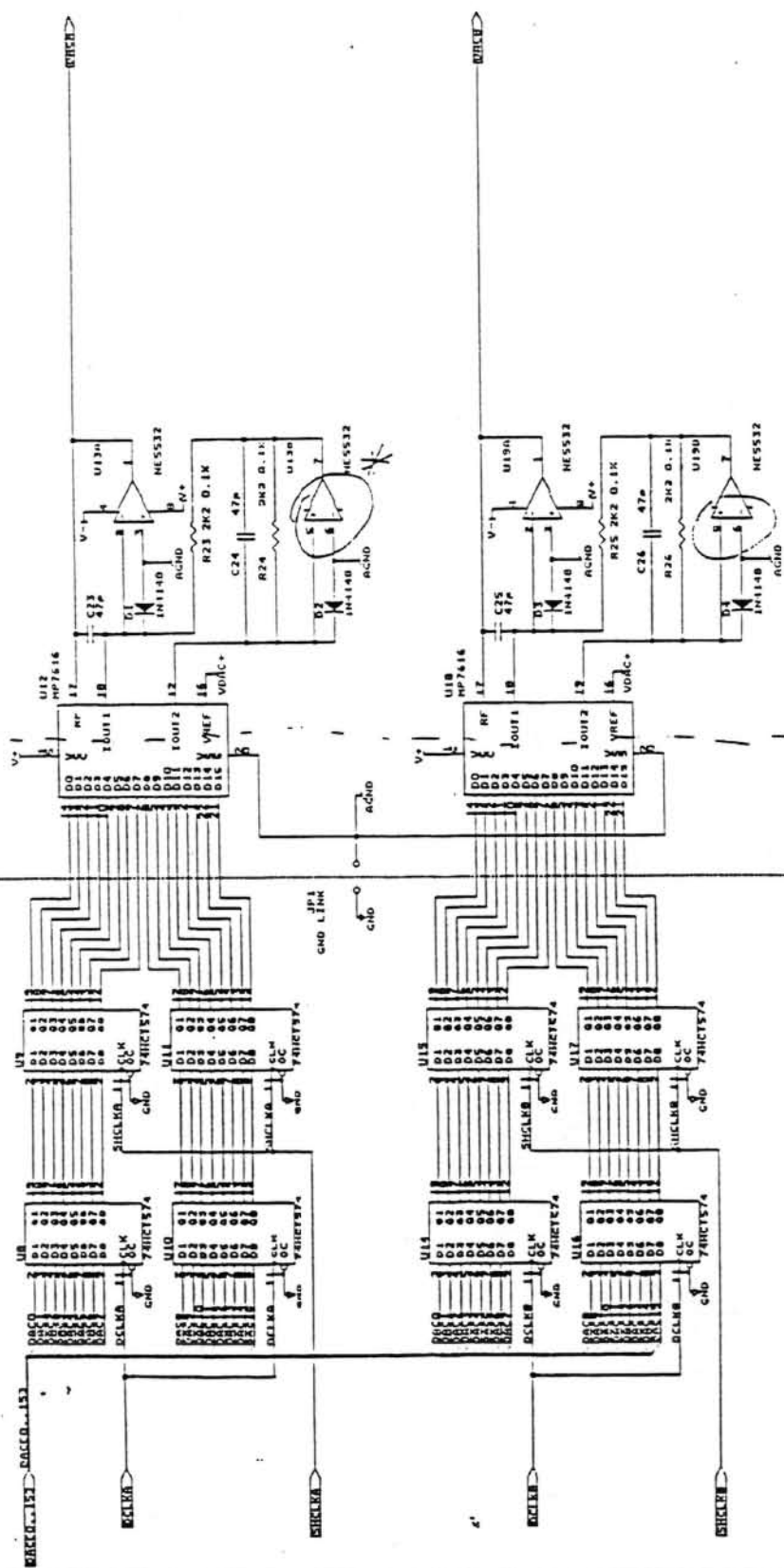

FILE	FAIRCHILD SSP
SIZE	DOCs
DOCUMENT NUMBER	DOC.SCH
DATE	OCTOBER 12, 1992/MSJ
PAGE	1 OF 2

PISTON-ADPAINA OND-HA ADAINA

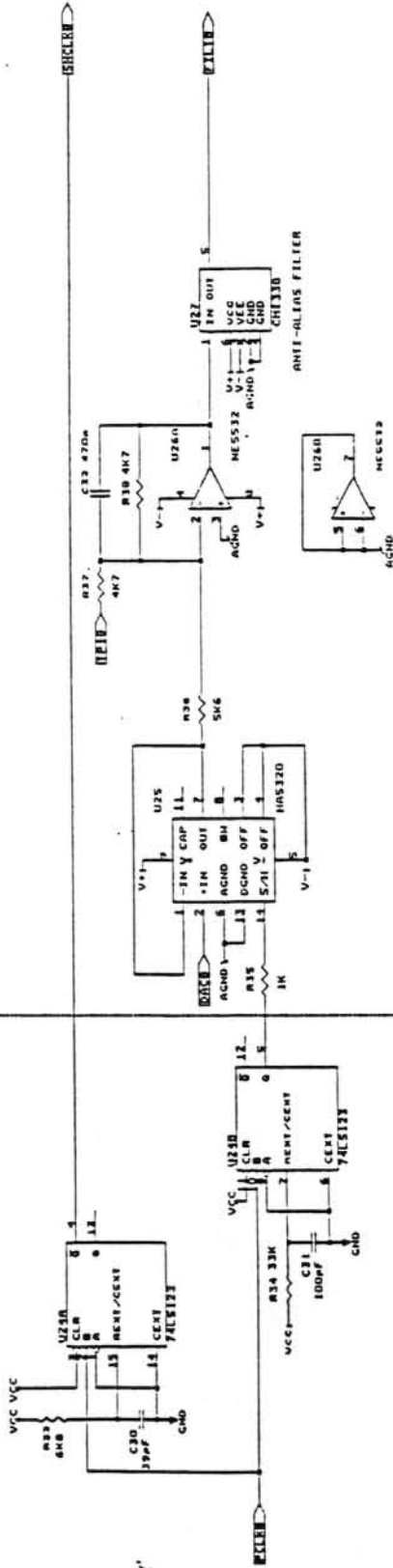
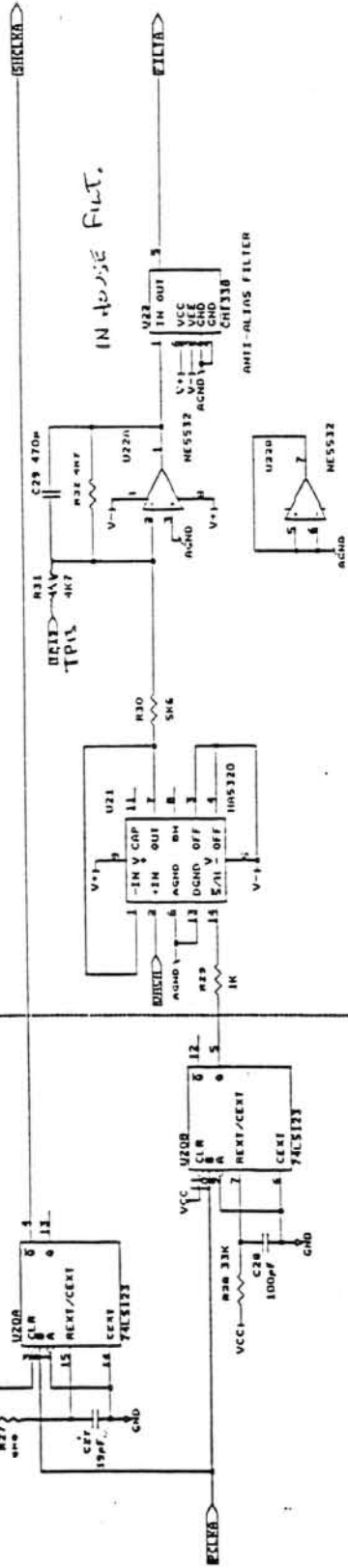

Part 1 of 2  
Title: SAMPLE AND HOLD / ANTI-ALIAS FILTER  
Rev: 2  
Date: 12/10/92  
Sheet: 4 of 8

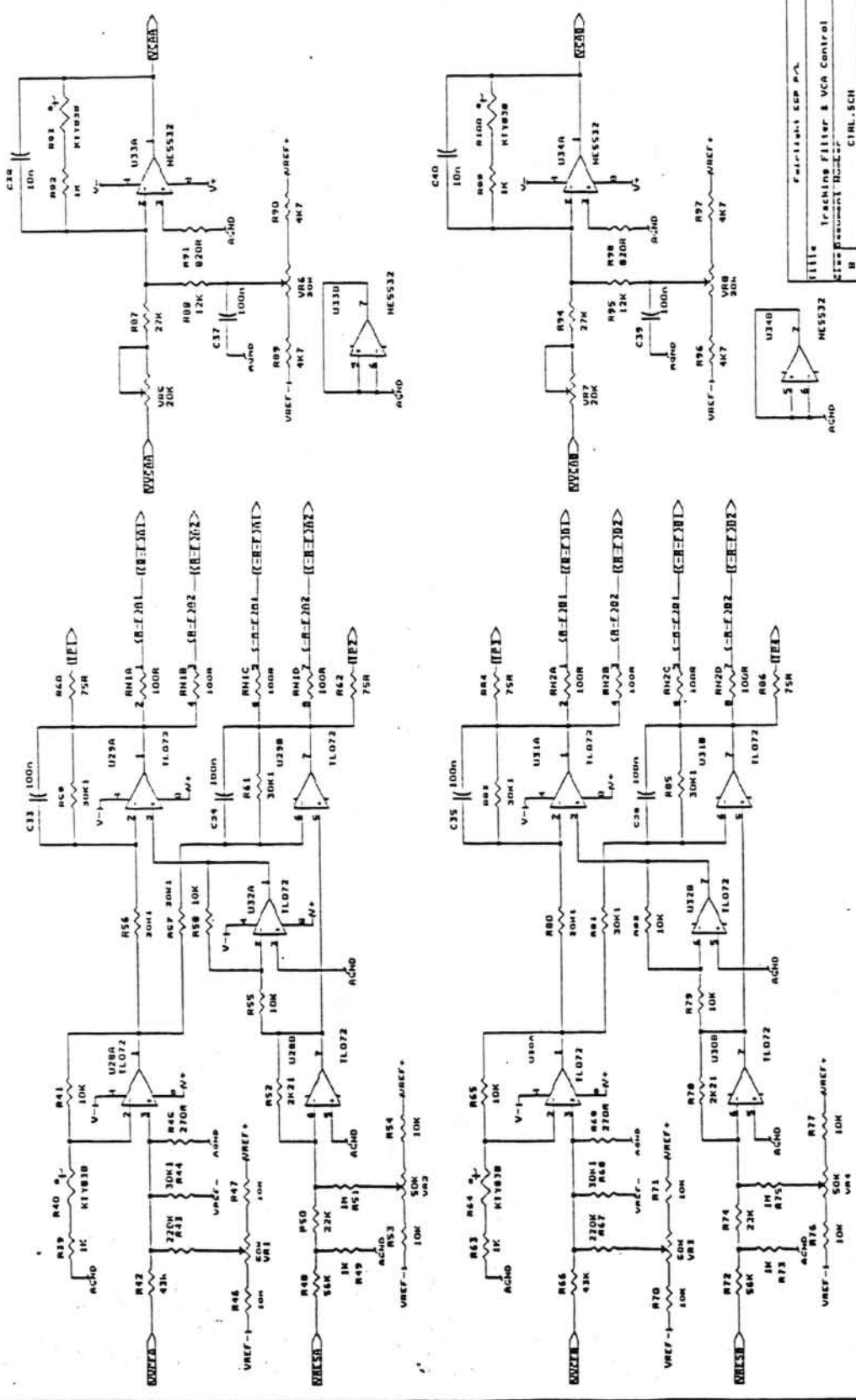

Title: Tracking Filter & VCA Control  
 Drawn: [Name]  
 Date: [Date]  
 Page: 2 of 2

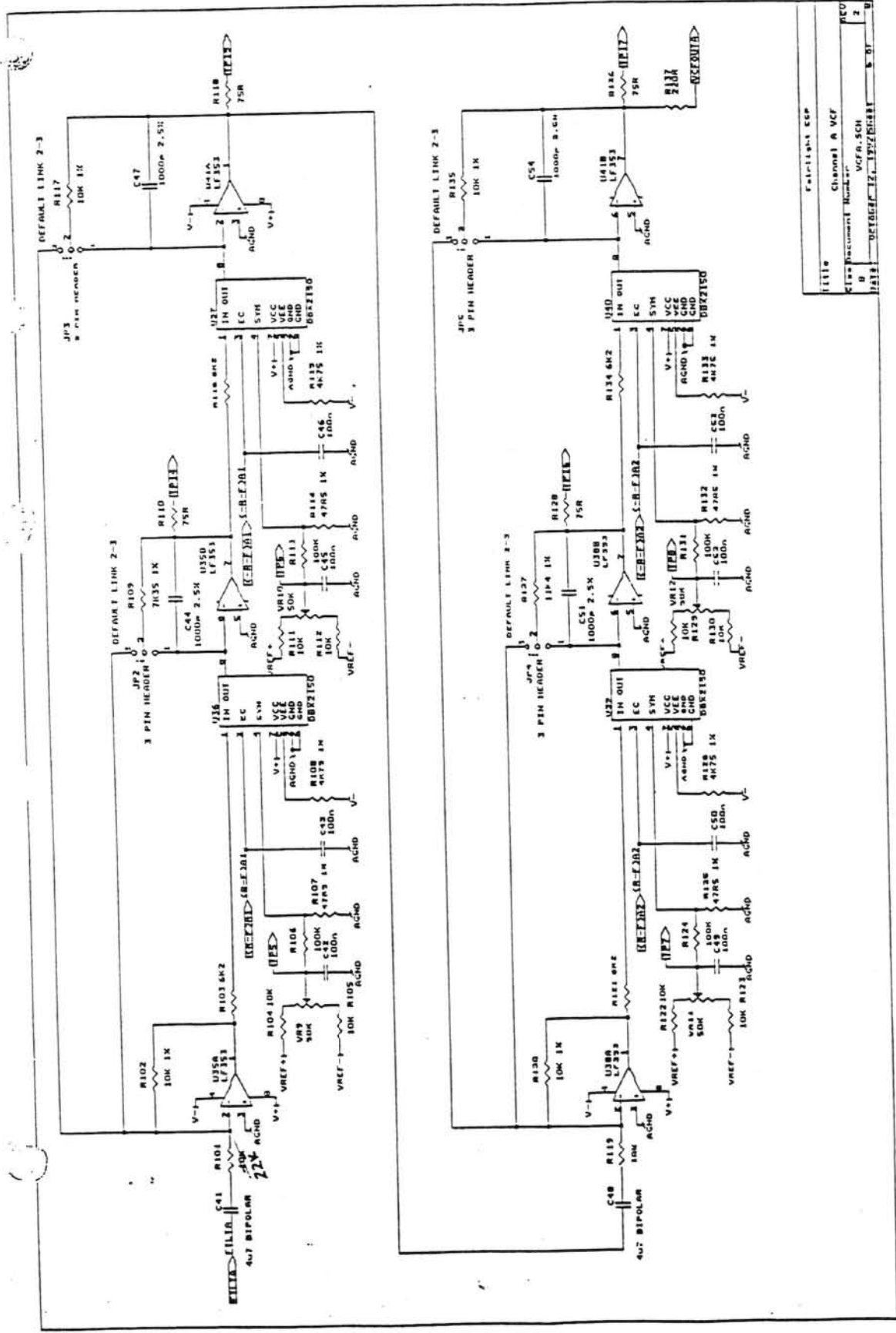

File	Fairlight.ksp
Channel	A VCF
Doc Path	VCFO.SCH
REV	2
DATE	02/08/91
BY	...

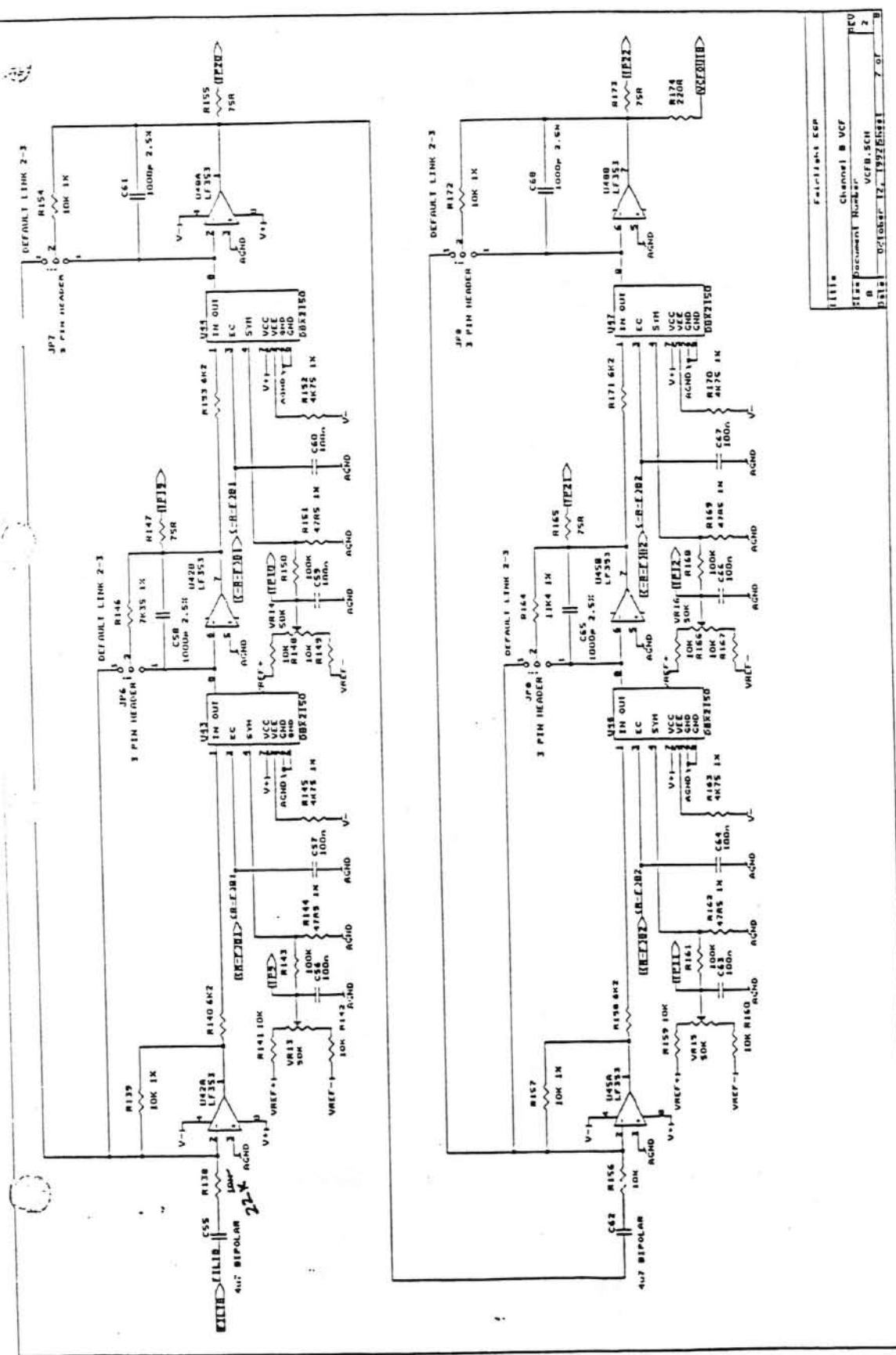

1111	Fairchild 68P
1112	Channel B VCF
1113	Document Number
1114	UCFB.SCH
1115	October 12, 1992
1116	7 of 8

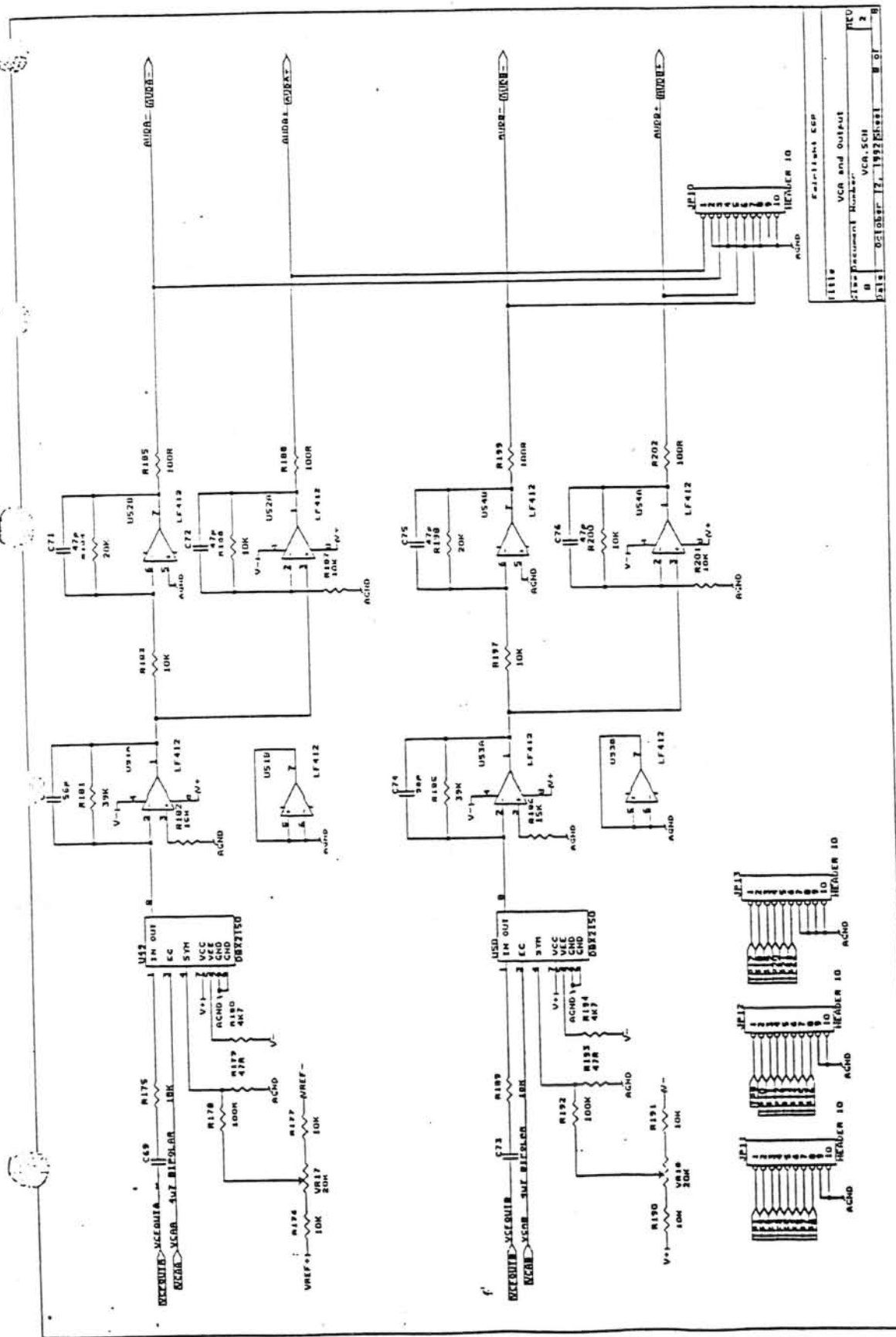

TITLE: Fairchild Cap  
 VCA and Output  
 Part Number: VCA.5CH  
 Date: October 17, 1992  
 Rev: B  
 Page: 2 of 8

B  
 A  
 DIST. (B)  
 DIST. (B)  
 (-25) B  
 25) B  
 (-25) A  
 (-75) A  
 DIST. E2(A)  
 DIST. E1(A)  
 5(S)  
 (B)  
 6(A)  
 TEP5(A)

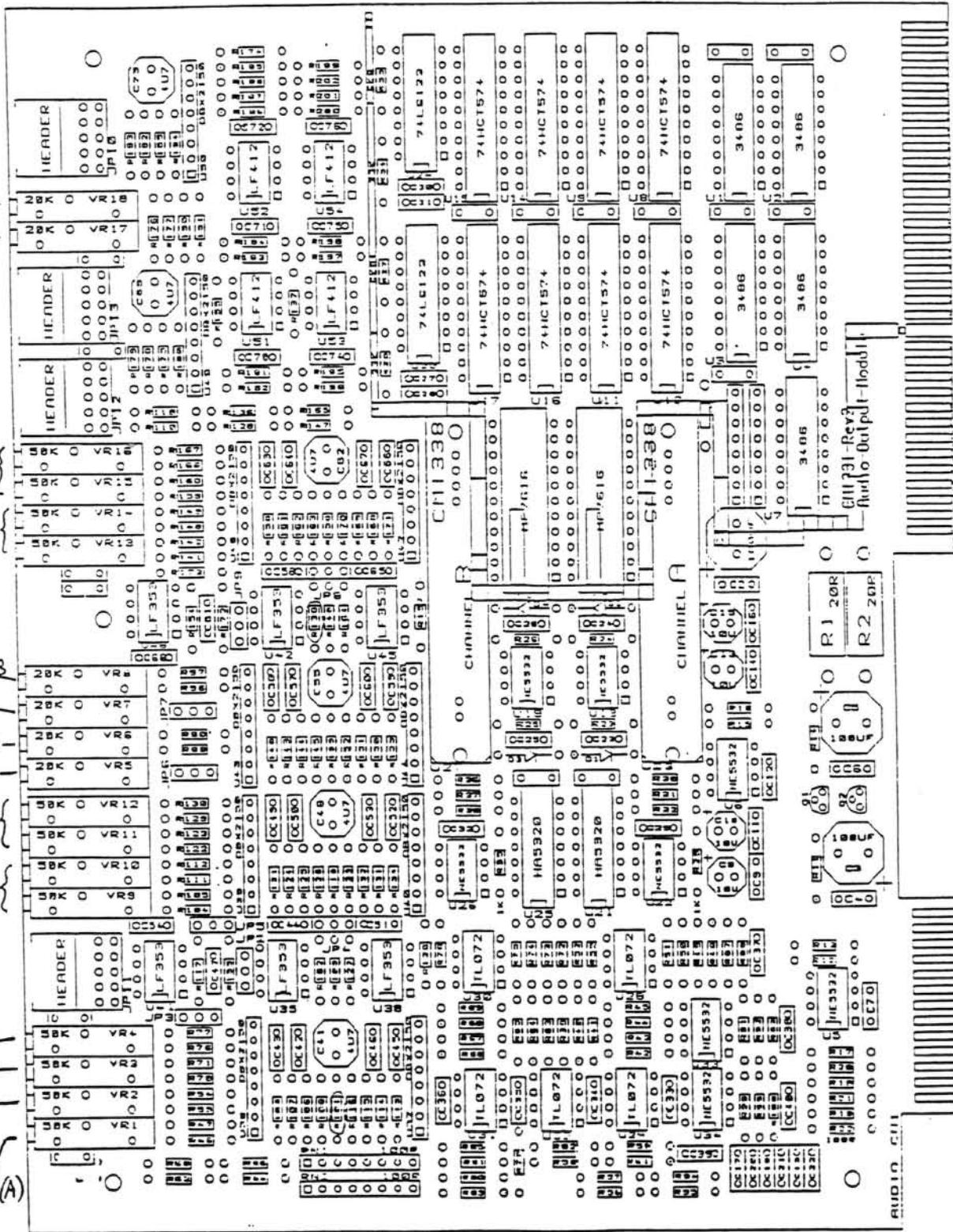

R101, 138 → 22 K

