

CMI-310

AUDIO PSU

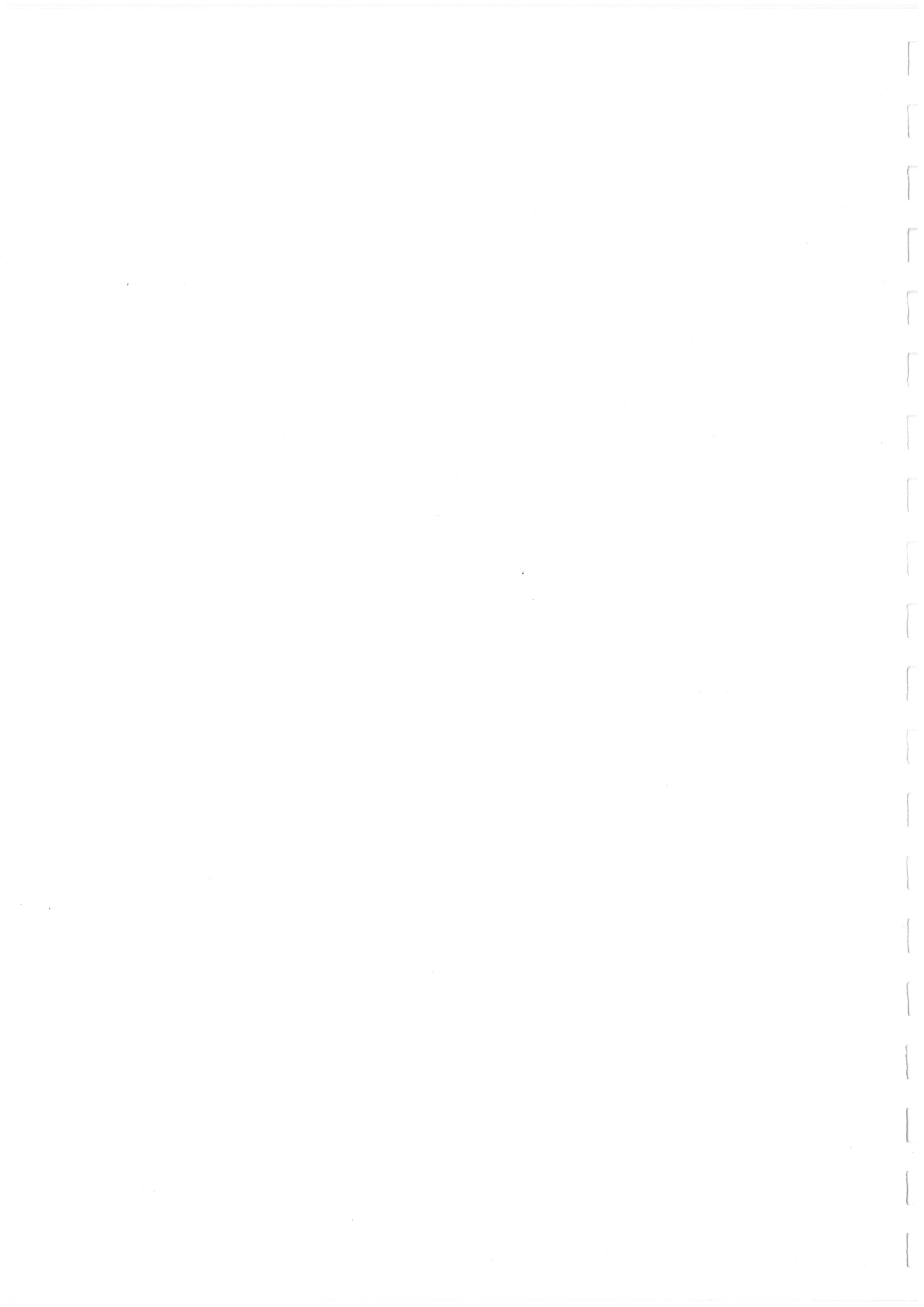

Terminology

APSU: Analog Power Supply Unit

AR: Audio Rack assembly

Introduction

The Analog Power Supply Unit (APSU) provides the rectified and filtered power to the VDU, Keyboards and Audio Rack components of the CMI. In addition it contains a tracking regulated +/-15 volt supply and a stereo headphone amplifier which gives the user a mixed output for non studio use.

Voltage Regulator

The Audio Rack (AR) unit is supplied with 3 amp regulated +/-15 volt supply by a tracking regulator IC (LM325) and associated bypass transistors. This regulator also supplies the Op-amps on the CMI-310.

Headphone Amplifier

The headphone amplifier is for amplifying the stereo outputs from both mixer modules which may be inserted in the audio rack. It consists of two LM380 IC amplifiers which are fed buffered signals from the audio motherboard. It can also mix the metronome output if desired.

Rectification and Filtering

(refer schematic CMI310-01)

The Alternating Current from the toroidal transformer comes in on connector SO1 (15 way). Various windings are used to generate the voltages for the CMI.

Connections 1 and 2 (16vac) are rectified by BR5, filtered by C34 and fused by F8 to supply the music keyboard +18 volts. LED 8, if inserted, confirms the fuse condition. LEDs 1 through 10 are not normally inserted as the CMI has these leds mounted on the rear panel circuit board CMI-317.

Connections 3 and 4 (16vac) are rectified by BR4 filtered by C33 and fused by F7 to supply the music keyboard -18 volts. LED 7, if fitted, shows the fuse state.

Connections 5 and 6 (9vac) are rectified by BR2, filtered by C30, fused by F6 to feed the music keyboard +10 volts. LED 6 shows the fuse state.

Connections 7, 8 and 9 (+/-18vac) are rectified by BR3, filtered by C31 and C32, fused by F4 and F5 to supply the Audio Rack 15 volt regulator (see later circuit description). LEDs 4 and 5 indicate fuse condition.

Connections 10, 11, 12 and 13 (+18,+8,common and -18vac respectively) are for the sampling card supply.

Connections 10 and 13 (+18, -18vac with reference to pin 12) are rectified by BR1 filtered by C27 and C28 and fused by F2 and F3 to supply the sampling card +20 and -20vdc supplies. LEDs 2 and 3 show the fuse states.

Connection 11 (8vac with reference to pin 12) is rectified by D5, filtered by F1 to feed the +10 volts DC to the sampler.

Connections 14 and 15 are the 16vac for the VDU which is fused by F9. LED 9 indicates the fuse condition.

CMI-310 Audio PSU & Headphone Amp

Voltage Regulator

(refer schematic CMI310-02)

The +/- 15 volt regulation for the Audio modules is provided by the LM325 IC and bypass transistors T1 and T2. Resistor R36 provides the current limit of just over 3 amps for the +15 volt while R39 provides the -15 volt limit. Diodes D7 and D2 protect transistors T1 and T2 from excessive reverse voltage during transient conditions at power up and power down times.

Diode D3 and Thyristor TH1 (C122E) are a crowbar protection circuit for the +15 volt supply to help prevent faulty transistors from damaging audio circuitry. Similarly D4, Q1 and TH2 protect the -15 volt supply from over voltage. These operate by sensing an over-voltage condition and firing the thyristor to blow the fuse. This saves the audio circuitry from damage.

Headphone Amplifier

(refer schematic CMI310-03 -05)

The incoming audio signals are buffered by IC IML (LF347) then converted to unipolar signals and filtered to remove high frequency noise (induced from various sources into the Audio Motherboard and cabling) by IC 2M (LF353). The metronome is buffered by IC 2L then fed to the metronome level pot and again buffered before being mixed into the headphone amplifiers.

The audio signal from the level pot is mixed with the metronome output and passed through a simple filter then amplified by the LM380s (one for right and one for left). The inverting input is used on the LM380 for improved stability with a high impedance source. A 470 uF cap provides DC isolation for the output and a 10R protects from short circuit loads. The 7815 regulator provides a direct low impedance supply for the LM380s to improve isolation and stability.

Rectifiers, Filters and Indicators

DRAWN: RII REVISION: 2.A

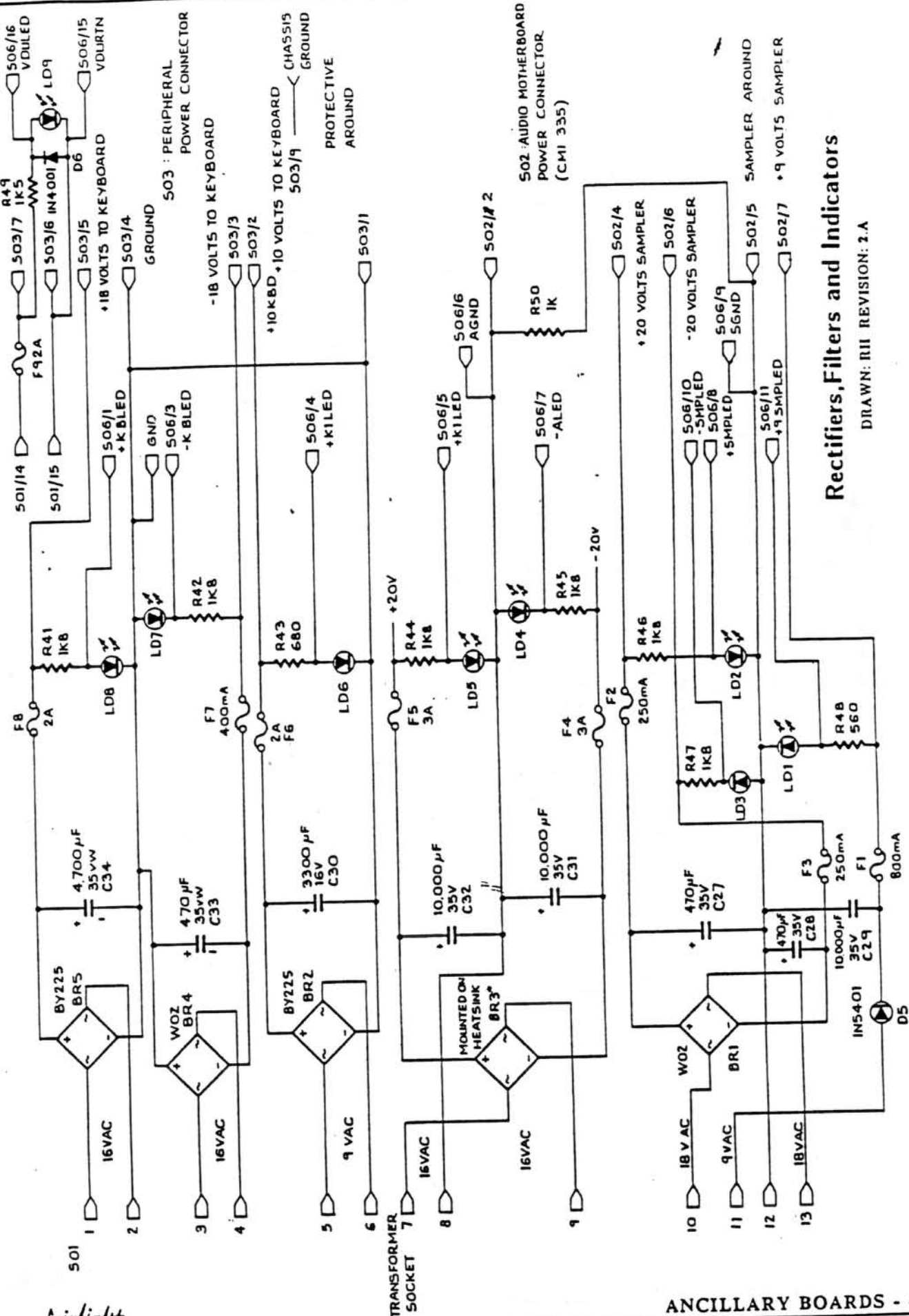

twilight

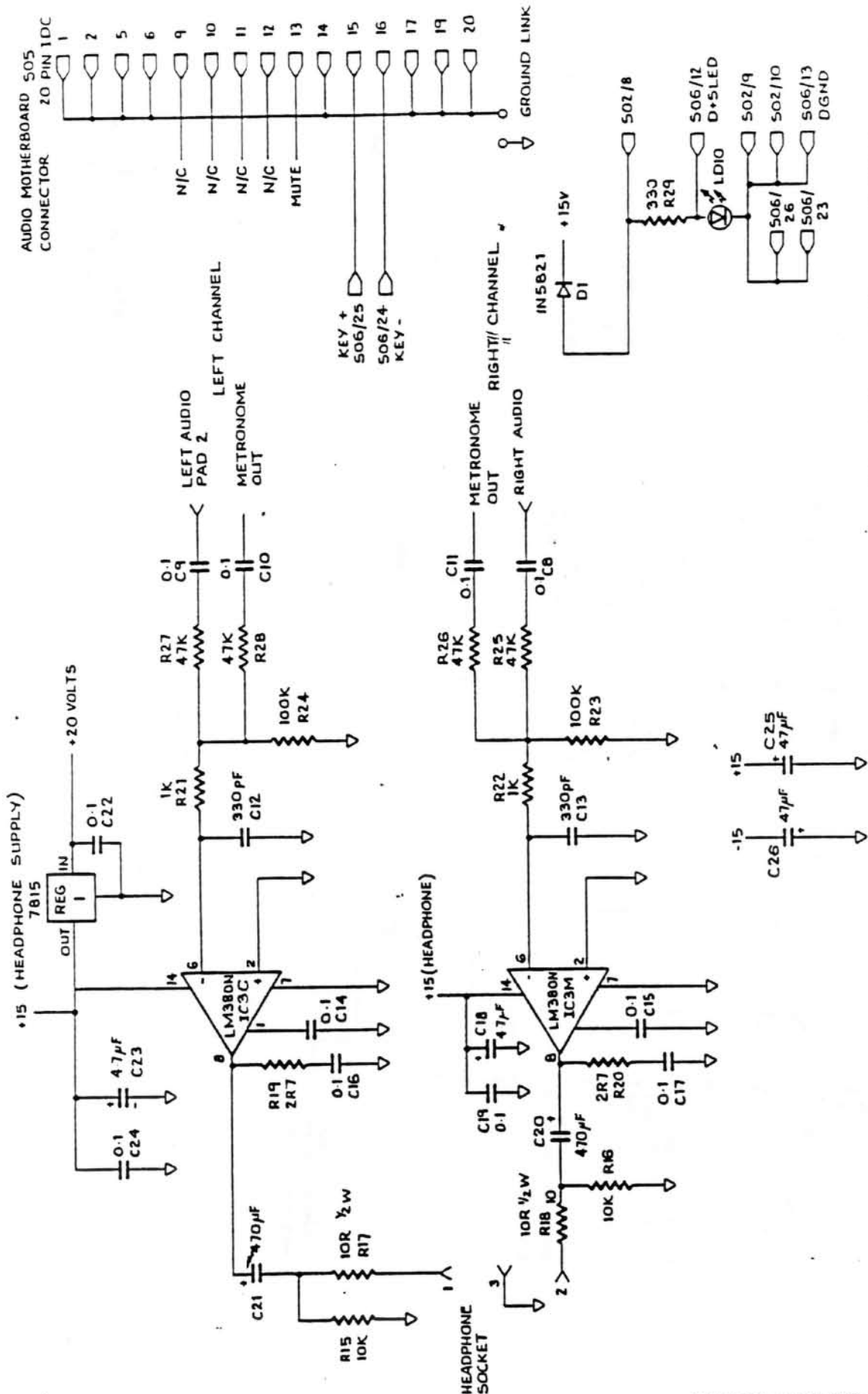

Headphone Mixer and Metronome

DRAWN: RII REVISION: 2.A

fairlight

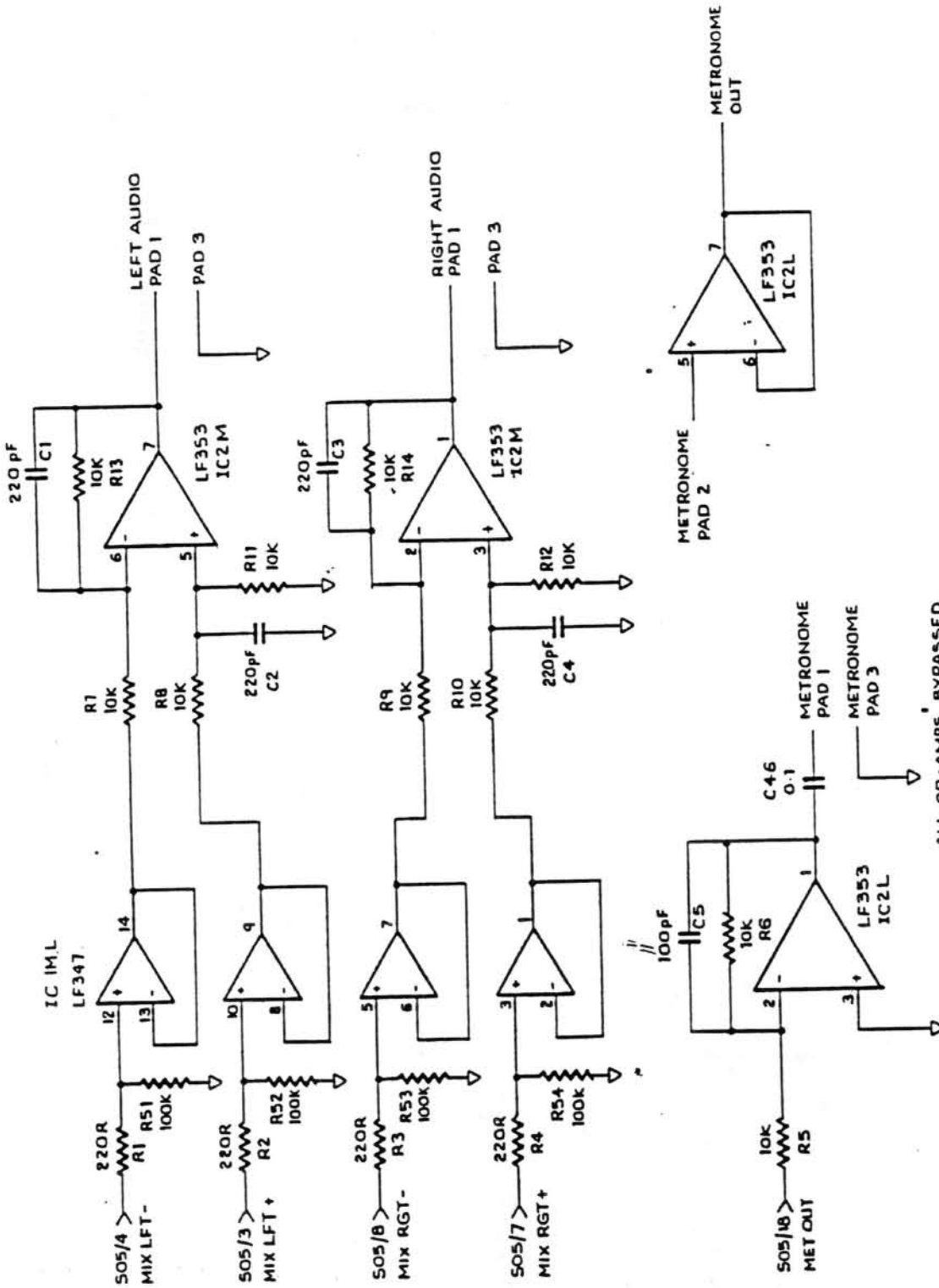

Audio Buffers and Mixing

DRAWN: RII REVISION: 1.A

ALL OP-AMPS BYPASSED BY 0.1 FROM +V TO AGND AND FROM -V TO AGND