

**Casio**  
**MIDI Guitar**  
**MG-500/510**  
**Player's**  
**Manual ... 1**

**Manual del**  
**Usuario**  
**... 25**



© 1990

**CASIO®**

**Casio MIDI Guitar  
MG-500/510  
Player's Manual**

Thank you and congratulations on your choice of a CASIO MG Series MIDI Guitar. Your new MIDI Guitar lets you take advantage of the freedom of musical expression provided by the electric guitar, while making use of the unlimited sound creation potential of MIDI sound sources such as digital synthesizers. To obtain optimum performance and assure long-term reliability, be sure to read this manual carefully before using your new MG Series Guitar.

**Contents**

<b>3</b>	<b>The Basics</b>
3	Supplying Power to Your Guitar
4	Changing Strings
5	Tuning the MIDI Guitar
5	To tune your guitar
6	To adjust octave tuning
<b>7</b>	<b>Performance</b>
7	POLY/MONO Performance Modes
7	To select the performance mode
7	To perform in the POLY mode
8	To perform in the MONO mode
9	Normal and Chromatic Performance
<b>10</b>	<b>MIDI</b>
10	Mixing MIDI and Guitar Sounds
10	To play only MIDI sounds
10	To play only guitar sounds
10	To mix MIDI and guitar sounds
11	Raising/Lowering MIDI Sound Octaves
11	Making Program Changes
13	MIDI Bend Range
<b>14</b>	<b>Adjustments</b>
14	MIDI Pickup Sensitivity
15	Neck Curvature
16	Machine Head Torque
16	Adjusting Guitar Pickup Height
16	Adjusting Bridge Height
<b>17</b>	<b>Taking Care of Your MG Series MIDI Guitar</b>
<b>18</b>	<b>General Guide — An Overall View of the MIDI Guitar</b>
<b>21</b>	<b>Specifications</b>
<b>22</b>	<b>Microswitches</b>

## Supplying Power to Your Guitar

In addition to being a "normal" electric guitar, your MG Series guitar features MIDI circuitry which requires electricity for operation.

To power the MIDI guitar, you can connect an optional AC adaptor (AD-5), or use 6 AA (SUM-3) batteries. When you're not using your guitar as a MIDI controller, batteries or AC power is not necessary.

If the power indicator on the front panel seems dim when you turn the power ON, it's probably time to change batteries.

When changing batteries, be sure to replace all 6 at the same time. If battery power is too weak, your guitar's MIDI functions may operate abnormally.

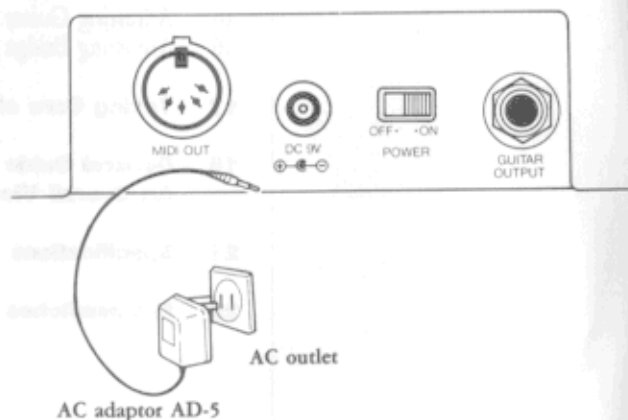
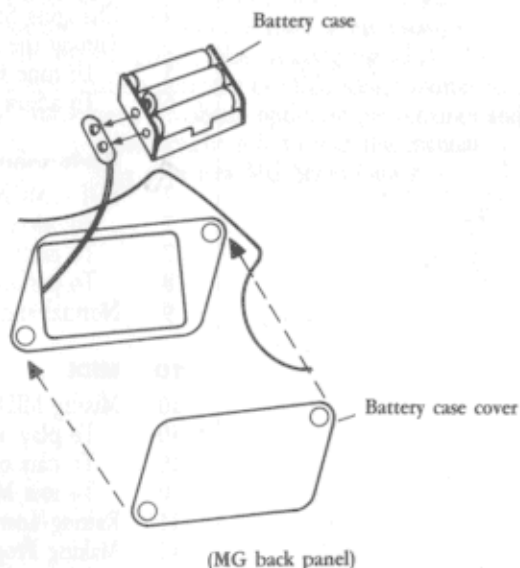

## Changing Strings

Change strings whenever they become worn or lose their brilliance (hopefully before they become corroded or rusty!). You'll find that fresh strings not only sound better, they're easier to keep in tune as well (once they've gotten past the initial "stretching" stage). They're also easier to play than old ones.

When you've finished playing, be sure to wipe the strings and frets with a dry cloth to prevent premature corrosion caused by hand perspiration.

### To change strings

- ① Insert the string through the appropriate hole in the back of the guitar so that it is held by the ball end.
- ② With the string in proper position over the bridge and nut, insert the tip of the string through the hole in the machine head post.
- ③ "Tie" the string off firmly.
- ④ Holding the string fairly taut with your right hand, wind up the excess string by turning the corresponding tuning knob with the other hand (or try using a tuning crank).
- ⑤ Once all strings are in place, tune and retune as necessary using the built-in electronic tuner. (See page 5 for tuning.)

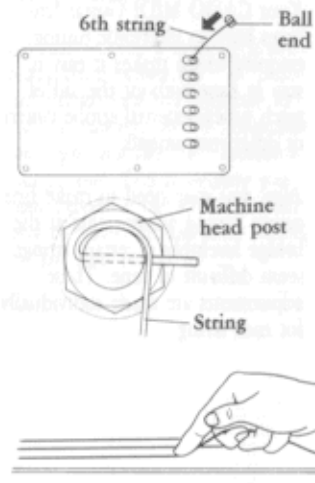

## Tuning the MIDI Guitar

Your CASIO MIDI Guitar features built-in electronic tuning circuitry which makes it easy to stay in tune without the aid of pitch pipes, external strobe tuners or other instruments.

Also, you may need to make fine octave tuning adjustments at the bridge assembly if certain strings seem difficult to tune. These adjustments are made individually for each string.

### To tune your guitar

① Select the frequency of the standard pitch (A4).

Before actually tuning your guitar strings, you can use microswitches number 8 and 9 on the back of the guitar to select the frequency of the standard pitch you will tune to.

This is simply a basis to work from when you tune your guitar — if one note is in tune you can tune the others to it.

As with other instruments, the MIDI guitar uses A4 as the standard pitch. You can specify the frequency of A4 by turning the microswitches ON or OFF according to the chart shown on the right.

② Tune each string by using the tuning indicators.

Notice that there are two arrows which light up when you play an open string on the guitar. These are the tuning indicators.

One is marked “#” indicating that the open string being played is sharp, and the other is marked “b” indicating that the open string being played is flat.

When these indicators light simultaneously, the string is in tune (within  $\pm 3$  cents).



Microswitches

SW8	SW9	Freq.
Off	Off	440Hz
On	Off	441Hz
Off	On	442Hz
On	On	443Hz

*The microswitches and MIDI sensitivity controls on the back of the guitar are protected by black rubber covers. These controls are made up of precision electronic components which may be damaged if exposed to static electricity or foreign elements, so be sure to replace the rubber covers after making any adjustments.*

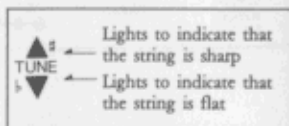

*If two or more strings are played simultaneously, both the “#” and “b” indicators will not light.*

You can tune each string by playing it open or at the octave (12th fret). For increased accuracy, you might find it best to tune each string open first, then check the tuning at the 12th fret and make any necessary fine adjustment.

③ Tune the MIDI sound source to the MG Series guitar.

In order to play totally “in tune,” your MIDI sound source should be tuned to the MIDI guitar. You might also try to detune one or the other for some interesting effects.

### To adjust octave tuning

● Play the string open and then at the octave (12th fret).

● If the pitch is slightly sharp at the 12th fret, turn the corresponding bridge adjustment screw slightly to the left (A) and check open/octave tuning again.

● If the pitch is slightly flat at the 12th fret, turn the corresponding bridge adjustment screw slightly to the right (B) and check open/octave tuning again.

*It's important to note that each time a string's pitch is raised 550 cents over its standard tuning, the tuner automatically “shifts” into the next octave.*

*Because of this, if a string is already sharp (when the “#” indicator is lit) and you continue to raise its tuning, the “b” indicator will light and the “#” indicator will go out. This is because you have exceeded the 550 cent limit and the tuner is indicating tuning for the next octave up.*

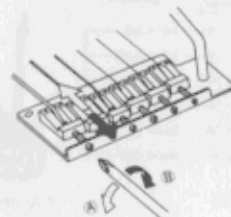

## POLY/MONO Performance Modes

The MIDI guitar is capable of MIDI performances in either POLY or MONO modes. In the POLY mode, all six strings can be used to control the same MIDI timbre. In the MONO mode, it is possible to assign each string a different sound source.

### To select the performance mode

- Switch the MIDI/Guitar Selector to the "MIDI" position. (A)
- Turn microswitch number 1 ON or OFF, according to the chart. (B)



### To perform in the POLY mode

In the POLY mode, all 6 strings control the same MIDI timbre.

- Set the guitar to the POLY mode (see chart B).
- Make sure that the MIDI sound source is set to the same MIDI receive channel as the MIDI transmit channel of the guitar (see chart C).
- Align MIDI bend range of guitar and sound source (see page 13).

(B)

SW1	MODE
OFF	POLY (MODE 3*)
ON	MONO (MODE 4)

\*See MIDI Implementation Chart.

© <MIDI guitar MIDI Transmission channel> ○ = OFF ● = ON

Transmission Channel		SW2	SW3	SW4	SW5
POLY mode SW1 = OFF	MONO mode SW1 = ON				
1	1-6	○	○	○	○
2	2-7	●	○	○	○
3	3-8	○	●	○	○
4	4-9	●	●	○	○
5	5-10	○	○	●	○
6	6-11	●	○	●	○
7	7-12	○	●	●	○
8	8-13	●	●	●	○
9	9-14	○	○	○	●
10	10-15	●	○	○	●
11	11-16	○	●	○	●
12	11-16	●	●	○	●
13	11-16	○	○	●	●
14	11-16	●	○	●	●
15	11-16	○	●	●	●
16	11-16	●	●	●	●

### To perform in the MONO mode

In the MONO mode, each string can be used to control a different MIDI timbre.

- Set the guitar to the MONO mode (see page 7 chart B).
- Make sure that the MIDI transmit channel numbers of each string correspond to the MIDI receive channels of sound source(s).
- Align MIDI bend range of guitar and sound sources (see page 13).

#### TRANSMIT CHANNELS IN THE MONO MODE

String	Channel
1	Basic channel
2	Basic channel + 1
3	Basic channel + 2
4	Basic channel + 3
5	Basic channel + 4
6	Basic channel + 5

In the MONO mode, MAIN (MIDI) VOLUME, PROGRAM CHANGE and BEND RANGE (a. CASIO exclusive) messages are transmitted for all strings. Because of this, bending of multiple strings is possible.

(Example)  
Using the MIDI guitar to control 6 sound sources (or MIDI timbres).

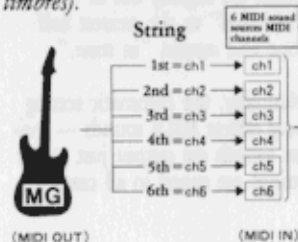

If you're using a sound source such as the Casio CZ-1 or CZ-5000 which is capable of receiving MIDI MONO mode messages, you can control up to 6 voices through a single unit (providing the sound source features 6 sound source channels).

## Normal and Chromatic Performance

Using the NORMAL/CHROMATIC/PROGRAM CHANGE selector, you can select from either the NORMAL performance mode or the CHROMATIC performance mode.

In the normal position, you can bend the notes of MIDI sounds in the same way that you bend normal guitar sounds. In the chromatic position, MIDI sounds bend only chromatically — in half tone increments.

Another interesting feature of chromatic performance is that it can aid you in staying in tune when playing only MIDI sounds.

Since all MIDI sound notes are sensed chromatically in this mode, notes played on strings which are slightly out of tune are "rounded" to the nearest half tone and output "in tune."

Naturally, the chromatic setting only effects MIDI sounds — guitar sounds are output just as the strings are tuned in all cases.



*In the POLY mode, normal MIDI bend is only possible on one string at a time. If you attempt to bend two or more strings at once, MIDI sounds bend only chromatically.*

## Mixing MIDI and Guitar Sounds

By using the MIDI/Guitar selector, you can mix both MIDI and Guitar sounds, or play either sound independently.

With some MIDI timbres, you may find it useful to mix in the Guitar sound to pick up the initial string attack, which is a bit delayed when output only as a MIDI sound. Or you may want to play straight guitar in some cases, or even straight MIDI sounds.

By experimenting with various MIDI timbres and mixes, you'll be able to create a wide range of unique sounds and effects.

### To play only MIDI sounds

● Move the MIDI/Guitar selector into the MIDI position.

You can control the overall volume of the MIDI sound(s) by using the MIDI volume control. Note, however, that this only works with MIDI instruments or devices which are capable of receiving MIDI Control Change message number 7 (see MIDI Implementation Chart).

If you're performing in the MONO mode, with more than one MIDI timbre, you can control the relative volumes of all voices by adjusting the output volume at the MIDI sound source(s).

### To play only guitar sounds

● Move the MIDI/Guitar selector into the Guitar position.

You can control the overall volume and tone of the Guitar sound(s) by using the guitar volume and tone controls. If the MIDI/Guitar selector is switched to the Guitar position, the MIDI sound is cut off (a MIDI NOTE OFF message is sent).

### To mix MIDI and guitar sounds

● Move the MIDI/Guitar selector into the GUITAR & MIDI position.

You can mix the relative volumes of the Guitar and MIDI sounds by using the guitar and MIDI volume controls.



## Raising/Lowering MIDI Sound Octaves

By using the octave selector, you can raise or lower the octave of MIDI sound output.

### To raise or lower MIDI octave

- In the NORMAL position, MIDI sounds are output in the same octave as the guitar sound (corresponding to normal note numbers).
- To raise MIDI sound pitch by one full octave, move the selector to the UP position.
- To lower MIDI sound pitch by one full octave, move the selector to the DOWN position.

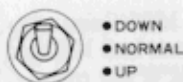

The octave selector setting only relates to MIDI sounds, and has no effect on natural guitar sounds.

## Making Program Changes

MG Series guitars let you make "remote" selection of MIDI voices. You can change the selected MIDI program (voice) number from the guitar — without having to use controls on the MIDI sound source.

### To make program changes

- Move the Normal/Chromatic/Program Change selector into the PROGRAM CHANGE position. (A)

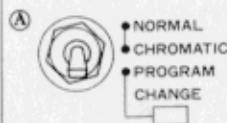

Before making a program change, check to make sure that the program change indicator is flashing. If any strings are still vibrating, the Program Change indicator will not flash. Mute the strings so that the indicator flashes.

- With the Program Change indicator flashing, finger and play the note corresponding to the MIDI Program Number you want to select. The indicator lights solid momentarily during Program Change registration.

If you want to change the selected program number again, mute the strings so that the indicator flashes and then play another note corresponding to the program number you want to select.

- Return the selector to the NORMAL or CHROMATIC position for performance.

Program Change numbers are assigned to various strings and frets as shown in the chart shown below.(B)

Program number assignments shown in the below chart (B) are only applicable when standard guitar tuning is used (E-A-D-G-B-E).

If string bends are made while making program changes the Program Change number is shifted as well.

(B)

String Nos.	Fret Nos.	MIDI Program Change Nos.
1	1~16	00~15
2	1~16	16~31
3	1~16	32~47
4	1~16	48~63
5	1~16	64~79
6	1~16	80~95

It's important to note that MIDI Program Change numbers are not synonymous with "voice" or "program" numbers on your MIDI sound source. Naturally, the program or voice numbering system for individual instruments are different.

## Setting Lowering MIDI Sound Octaves

The chart listed below (C) shows an example of the relationship between Program Change numbers and voice numbers when using the CASIO CZ-1 Digital Synthesizer as a sound source.

When using other MIDI sound sources, refer to the MIDI implementation chart which was supplied with the instrument (or device).

### (C) Example

String Nos.	Fret. Nos.	MIDI Program change Nos.	CZ-1 Voice Nos. & Name
1	1	(00)	A-1 Brass 1
1	9	(08)	B-1 Aco. Guitar
2	3	(18)	C-3 Cello
4	16	(63)	H-8 Typhoon Sound

## MIDI Bend Range

By setting MIDI bend range, you can establish how far up you can bend a MIDI sound note when the NORMAL/CHROMATIC switch is set to "NORMAL." Four different settings are possible, using microswitches 6 and 7.

SW6	SW7	Bend Range
OFF	OFF	* 12
ON	OFF	7
OFF	ON	5
ON	ON	4

(\*Units: half-tones)

When the NORMAL/CHROMATIC switch is set to "CHROMATIC" MIDI notes bend chromatically.

## MIDI Pickup Sensitivity

In some cases, you'll want to adjust the sensitivity of the MIDI pickup, for individual strings. When increased, NOTE ON messages are sent with only a light touch, as are maximum velocity messages. When decreased, the opposite is true.

For example, differences in string gauge or string height may cause an imbalance in MIDI sound characteristics.

A certain string or strings may stand out, while others seem too weak or don't sound at the same time. These problems can be solved by increasing or decreasing MIDI pickup sensitivity.

In some cases, if you use sound sources which feature MIDI Touch Sensitivity you may need to decrease MIDI pickup sensitivity for best results.

### To adjust MIDI pickup sensitivity

① Remove the rubber cover protecting the sensitivity adjustment screws on the back of the guitar.

② To increase MIDI pickup sensitivity for a certain string, turn the corresponding adjustment screw to the left. (A)

• To decrease MIDI pickup sensitivity for a certain string, turn the corresponding adjustment screw to the right. (B)

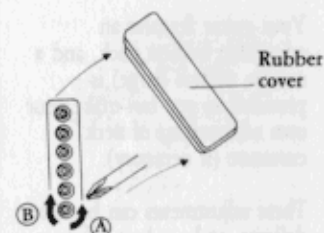

These adjustments are delicate. Do not turn the microswitches more than 100° (about a quarter turn) in each direction.

Do not use excessive force when making MIDI pickup sensitivity adjustments.

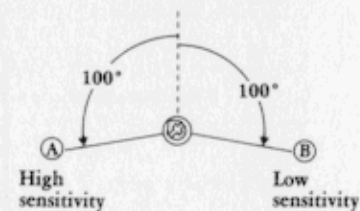

## Neck Curvature

Your guitar features an adjustable bolt-on neck, and a custom wrench (large) is provided so you can make your own adjustments of neck curvature (if necessary).

These adjustments can be rather delicate, and are best left to your local guitar service shop, however if necessary, you can make adjustments according to the basic rules and procedures that follows.

### To adjust neck curvature

① With the guitar in normal tuning, hold down a string at both the 1st and 22nd frets (simultaneously).

② While pressing down the string at both frets, slide a playing card under the strings at the 12th fret.

You should be able to move the card freely in and out, without it touching either the frets or string, however if the distance between the string and fretboard is over 0.5mm, adjust neck curvature by turning the adjusting nut clockwise (toward the 6th string).

If the playing card does not slide easily between the string and fret, adjust the adjusting nut by turning it counterclockwise (toward the 1st string).

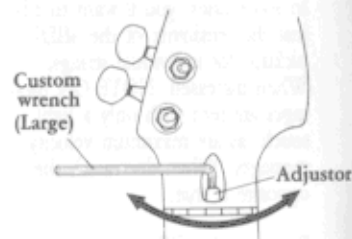

## Machine Head Torque

By adjusting the torque of the machine head, you can prevent strings from becoming detuned (to some extent).

### To adjust machine head torque

● Using a Philips screwdriver, tighten or loosen the screw holding each tuning knob. Turn to the left (B) to loosen torque and to the right (A) to tighten torque.

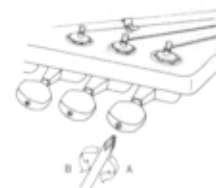

## Adjusting Guitar Pickup Height

By adjusting pickup height, you can make delicate adjustments in sound characteristics. When the pickup is brought closer to the strings (raised), the sound becomes fuller, while when the pickup is lowered the sound becomes thinner and sharper.

### To adjust pickup height

● Turn the screws at both sides of the pickup(s) to lower or raise the pickup.

As a basic rule, the surface of the pickups should be between 2 and 3mm from the strings when the strings are held down at the 22nd (top) fret.

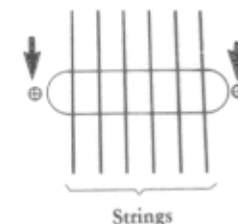

## Adjusting Bridge Height

Depending on the gauge of strings you will be using, the style of music and the type of sound you want to obtain, you'll probably want to adjust string height (distance from the fretboard and pickups), by raising or lowering the bridge for each string. A special wrench (small) is provided for this purpose.

### To adjust bridge height

● Using the small wrench which came with your guitar, raise or lower bridge height as shown in the diagram on the right.

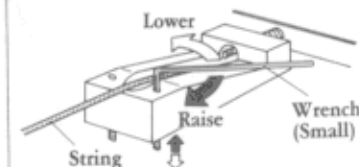

## Taking Care of Your MG Series MIDI Guitar

- Avoid extremes of temperature, excessive humidity and direct sunlight.
- Your guitar features precision electronic components. Any modification of, or tampering with internal components can be the cause of malfunctions or damage.
- Do not use alcohol, thinner or similar chemicals for cleaning.
- To preserve the life of strings and frets, always wipe your guitar with a clean, dry cloth after each use.
- When transporting your MIDI guitar, always put it in a hard or soft case for protection. It's also a good idea to remove the tremolo arm and loosen strings when transporting your instrument for long distances.
- Always replace the rubber covers on the rear of your guitar after making sensitivity or microswitch adjustments.

## General Guide — An Overall View of the MIDI guitar

Model: MG-500

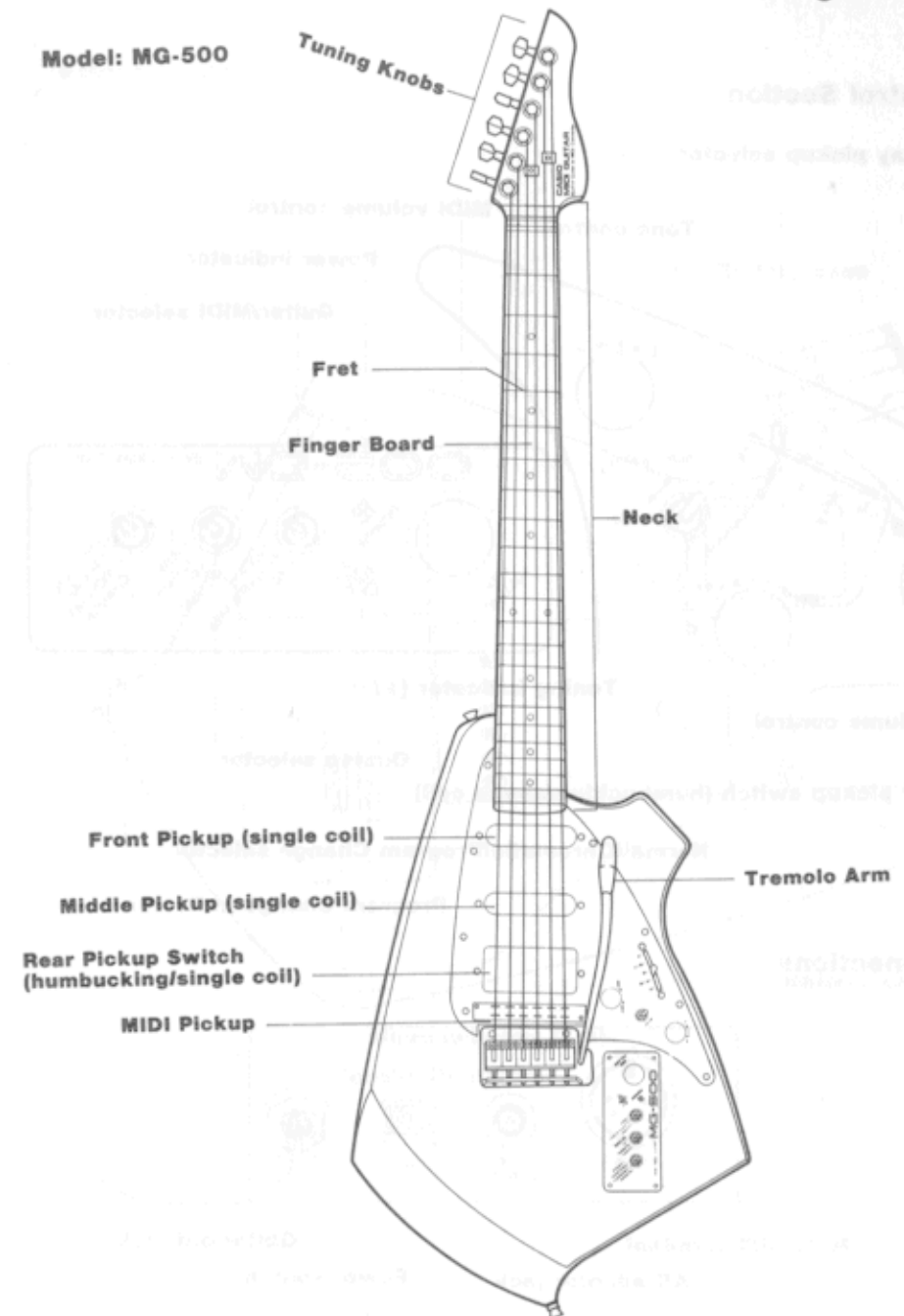

## ■ Control Section

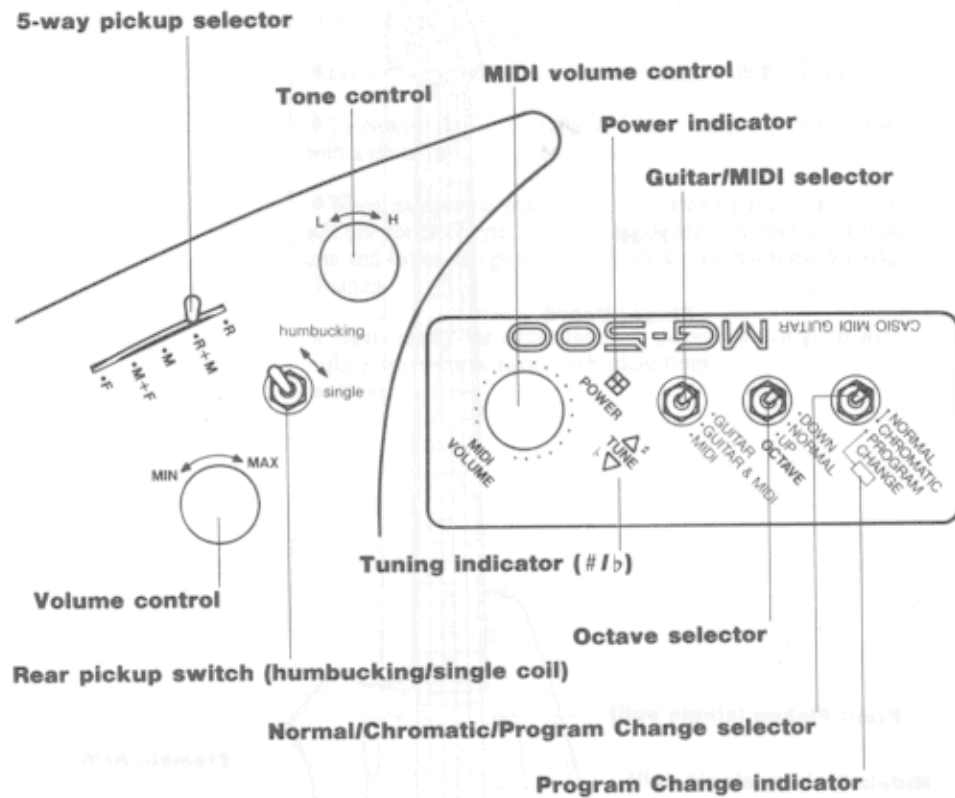

## ■ Connections

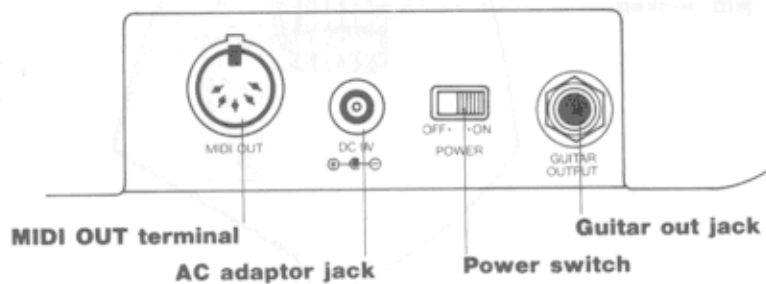

## ■ Back panels

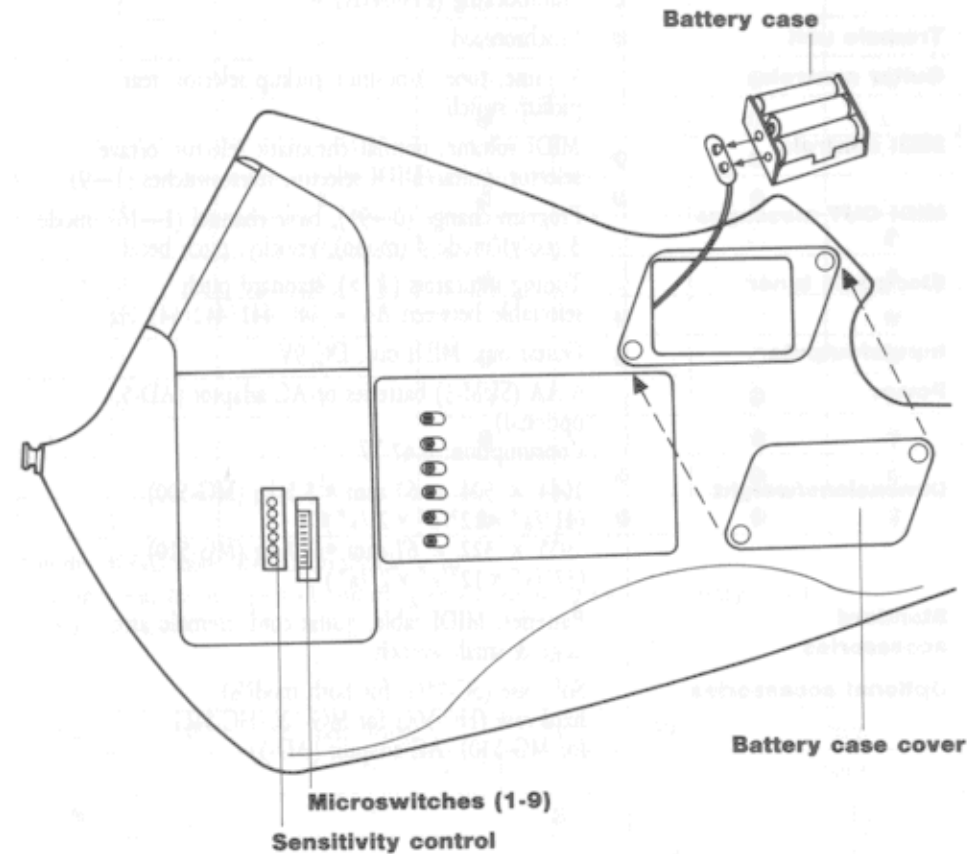

## Specifications

<b>Body</b>	Basswood
<b>Neck</b>	Maple
<b>Fingerboard</b>	Rosewood, 22 frets
<b>Pickups</b>	Single coil (PS-581A) × 2 Humbucking (PH-641A) × 1
<b>Tremolo unit</b>	Synchronized
<b>Guitar controls</b>	Volume, tone, 5-position pickup selector, rear pickup switch
<b>MIDI controls</b>	MIDI volume, normal/chromatic selector, octave selector, guitar/MIDI selector, microswitches (1—9)
<b>MIDI OUT messages</b>	Program change (0—95), basic channel (1—16), mode 3 (poly)/mode 4 (mono), velocity, pitch bend
<b>Electronic tuner</b>	Tuning indicators (#/b), standard pitch selectable between A4 = 440/441/442/443 Hz
<b>Inputs/outputs</b>	Guitar out, MIDI out, DC 9V
<b>Power</b>	6 AA (SUM-3) batteries or AC adaptor (AD-5, optional) Consumption: 0.47 W
<b>Dimensions/weight</b>	1044 × 304 × 67 mm • 3.5 kg (MG-500) (41 <sup>1</sup> / <sub>8</sub> " × 12 <sup>3</sup> / <sub>8</sub> " × 2 <sup>3</sup> / <sub>8</sub> ") 955 × 322 × 67 mm • 3.7 kg (MG-510) (37 <sup>3</sup> / <sub>8</sub> " × 12 <sup>3</sup> / <sub>8</sub> " × 2 <sup>3</sup> / <sub>8</sub> ")
<b>Standard accessories</b>	Batteries, MIDI cable, guitar cord, tremolo arm, large & small wrench
<b>Optional accessories</b>	Soft case (SC-75G, for both models) hard case (HC-50G for MG-500/HC-51G for MG-510), AC adaptor (AD-5)

\*Specifications subject to change without notice.

## Microswitches

○ = OFF ● = ON

Transmission Channel		SW2	SW3	SW4	SW5
POLY mode SW1 = OFF	MONO mode* SW1 = ON				
1	1	○	○	○	○
2	2	●	○	○	○
3	3	○	●	○	○
4	4	●	●	○	○
5	5	○	○	●	○
6	6	●	○	●	○
7	7	○	●	●	○
8	8	●	●	●	○
9	9	○	○	○	●
10	10	●	○	○	●
11	11	○	●	○	●
12	11	●	●	○	●
13	11	○	○	●	●
14	11	●	○	●	●
15	11	○	●	●	●
16	11	●	●	●	●

\* In the MONO mode (BASIC CHANNEL = n)

1st string = n, 2nd string = n + 1, 3rd string = n + 2, 4th string = n + 3, 5th string = n + 4,  
6th string = n + 5

SW6	SW7	Bend Range	SW8	SW9	Freq.
○	○	12	○	○	440Hz
●	○	7	●	○	441Hz
○	●	5	○	●	442Hz
●	●	4	●	●	443Hz