

YAMAHA® disklavier®

MX80 SYSTEMS

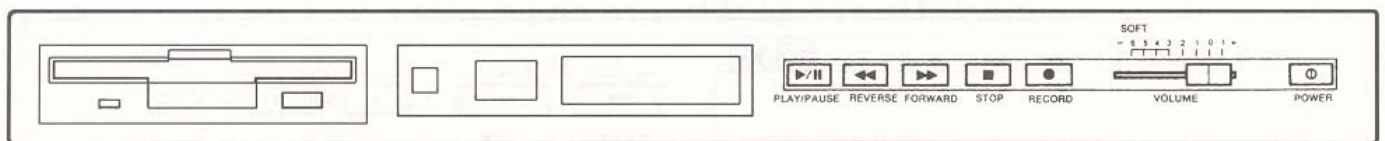

TABLE OF CONTENTS

MX80 SERIES

PROCEDURE	PAGE
1. DEALER PREP REFERENCE CHART	3
2. RECORD AND PLAYBACK TEST	4
3. REMOVING CASE PARTS AND ACTION	5
4. MINIMUM ACOUSTIC REGULATION	6
5. PEDAL ADJUSTMENT	7 – 10
6. KEY DRIVE UNIT HEIGHT ADJUSTMENT	11
7. KEY SENSOR TEST AND ADJUSTMENT	12
8. KEYBOARD TRIMMER SETTING AND ADJUSTMENT	13
9. KEYBOARD MEASUREMENT	14 – 15
10. CONTROL UNIT TESTING	16







DEALER PREP QUICK REFERENCE CHART

MX80 SERIES

1. UNPACK <ul style="list-style-type: none">• Remove foam packing between hammer rest rail and bracket• Remove rubber band from action bracket
2. PERFORM RECORD AND PLAYBACK TEST
3. REMOVE CASE PARTS
4. MINIMUM CHECKING AND ADJUSTMENT OF BASIC ACOUSTIC REGULATION <ul style="list-style-type: none">• Key height 19 to 20mm above key slip.• Ease keys as needed• Capstan adjustment (lost motion none)• Let off (3mm in the bass, graduating to 2mm in the treble)
5. PEDAL ADJUSTMENTS <ul style="list-style-type: none">• Adjust lost motion in damper and soft pedal (same as acoustic)• Adjust pedal drive solenoid gap (3 mm)• Adjust pedal sensors.• Make sure power is off and adjust the cord tension on the mute unit• Turn power on and set volume to -3 on the control unit.• Adjust the Soft Mode Switch (when engaged, hammer blow distance should be 16 mm +/- 3 mm• On both pedals, reconfirm that the solenoid gaps and the acoustic measurements are still within tolerance limits
6. CHECK KEY DRIVE UNIT HEIGHT AND ADJUST IF NECESSARY.
7. SENSOR TESTS <p>Key Sensors only. There are no hammer sensors to adjust</p>
8. KEYBOARD MEASUREMENT PROGRAM
9. TUNE AND VOICE
10. REPEAT RECORD AND PLAYBACK TEST.

Record and Playback Test

MX80 SERIES

PROCEDURE	RESULT	ADJUSTMENTS & COMMENTS
1. Press the  button.	Scrolling message is displayed on LCD.	
2. Insert a formatted disk. Careful! Right side up etc.		
3. Press the  button.	Green LED to the left of the  button will flash. Song number is displayed in 7 segment LCD to the left of the main display.	DKV is waiting for next command.
4. Press the  button to start recording.	Beep is heard.	The DKV is waiting for you to start playing.
5. Play each key chromatically, then depress and release right and left pedal.		Play each key slowly enough so that during playback you will be able to observe that each key performs correctly. Note: The MX80 series records both left and right pedals. During playback: a) Neither pedal moves. b) Dampers move.(Watch or listen) c) Hammer rest rail moves only during mute mode.
6. Press the  button.	LCD will display: <div style="border: 1px solid black; padding: 2px; width: fit-content; margin: 5px auto;">WRITING TO DISK, PLEASE WAIT</div>	
7. Press the  button to begin song playback.	Song number is displayed in 7 segment LCD to the left of the main display. Song begins to play.	
8. Press the  button.		
9. Check the Soft function movement by moving the volume slider to -3.	Hammers are moved to 15 to 16mm away from strings.	

HOW TO REMOVE THE CASE PARTS AND ACTION

MX80 SERIES

Case Parts

1. Turn the handle of the hinge pin parallel to the top board. (This disengages the two parts of the hinge).
2. Lift the top board from piano.
3. Unlock the wing locks that are located inside the corner of the front top board.
4. Remove the upper front top board and the fallboard as one unit.

Removing the Action

1. Remove the action bracket nuts.
2. Lift the action out (same as traditional acoustic piano).





MINIMUM ACOUSTIC ACTION REGULATION

MX80 SERIES

REGULATE:	SPECIFICATION & PROCEDURE
Key height	Approximately 19 to 20mm above key slip. Shim balance rail if necessary
Key fitting	<ul style="list-style-type: none"> • Should be very free. • Check front and key button bushing by moving key from side to side. • Check balance rail by raising key 5mm and releasing it. Key should fall freely. Check front.
Lost motion	Adjust capstan same as acoustic piano.
Let off	4mm in bass graduated to 2mm in treble. Let-off should be set approximately 1mm wider than it would be set on an acoustic piano.
Pedals	Pedal regulation is also necessary. There are significant differences between normal acoustic pedal regulation and Disklavier pedal regulation. Because pedal adjustment can have an impact on the overall calibration of the Disklavier, these procedures are discussed in depth in the "Pedal Adjustment" section.

PEDAL ADJUSTMENT

MX80 SERIES

PROCEDURE	RESULTS	ADJUSTMENTS & COMMENTS
1. Adjust Lost Motion on Loud Pedal and Soft Pedal	Same as acoustic standard for both pedals.	1. Adjust lost motion so that damper lift from the damper pedal equals the damper lift from a black key. Rotate wing nut on loud pedal. 2. Eliminate any lost motion for the soft pedal. Rotate wing nut on soft pedal. CAUTION! MAKE SURE HAMMER REST RAIL IS STILL IN CONTACT WITH THE ACTION BRACKET SUPPORT!
2. Adjust Pedal Drive Solenoid Gap (Loud Pedal Only) NOTE! The MX80 system does not have a solenoid on the soft pedal. The system only records the soft pedal, it does not play it back.	Solenoid gap is usually 4.5mm ~ 5.0mm with pedal at rest. Do not exceed 5mm!	1. The solenoid gap (A) for the Loud Pedal is simply adjusted by changing the wire length. (SEE DIAGRAM 1 ON PAGE 9.) To change the solenoid gap: 2. Loosen the two Phillips head screws on the wire holder. 3. Raise or Lower the wire holder on the damper pedal rod, so that a 5mm solenoid gap is achieved. 4. Retighten the two Phillips head screws on the wire holder. NOTE: If the solenoid gap exceeds 5mm, the solenoid will not function.
3. While pressing the  and  buttons, press the  button.	LCD will display the ROM version and Date	
4. Press the  button.	LCD will display: <div style="border: 1px solid black; padding: 5px; width: fit-content; margin: 5px auto;">(0) SENSOR TEST</div>	
5. Adjust Loud Pedal Sensor	Loud pedal sensor detect beep sounds when the dampers move 1.5 mm +/- 0.5mm off strings.	If the sensor detect beep sounds early or late on the loud pedal, rotate the Loud Pedal sensor adjustment screw. (SEE DIAGRAM 2 ON PAGE 9) <ul style="list-style-type: none"> • Clockwise to lower the sensor. • Counterclockwise to raise the sensor

PEDAL ADJUSTMENT (CONT.)

MX80 SERIES

PROCEDURE	RESULTS	ADJUSTMENTS & COMMENTS
6. Adjust Soft Pedal Sensor	Soft pedal sensor beep sounds when the hammer rail has moved 2-3 mm.	If the sensor detect beep sounds early or late on the soft pedal, slightly loosen the two Phillips head screws on the soft pedal sensor switch located on the soft pedal rod. (SEE DIAGRAM 3 ON PAGE 10.) Raise or lower the sensor switch by sliding it up or down the soft pedal rod. Retighten the two Phillips head screws after adjustment is made.
7. Turn off power on the control unit.	Exits from "TEST MODE".	
8. Adjust the cord tension on the mute unit.	Mute unit cord is not excessively loose or tight when the soft mode is off.	Adjust the cord tension by loosening the two Phillips head screws and raise or lower the cord holder on the soft pedal rod. Once adjusted, retighten the two Phillips head screws.
9. Turn on the power on the control unit.		
10. Slide the volume switch to -3 on the control unit.	Hammer rest rail should move closer to strings. Blow distance should be 16mm +/- 3mm in Soft mode.	If the mute motor brought the hammer blow distance too close or not close enough to the strings: <ol style="list-style-type: none"> 1. Loosen the two Phillips head screws on the Soft Mode Switch. (SEE DIAGRAMS 3 & 4 ON PAGE 10.) 2. Adjust switch up or down on the soft pedal rod, so that the mute motor brings the hammers to the correct blow distance when in Soft Mode.
11. Do a RECORD and PLAY/BACK test.	Check pedal adjustments.	

DIAGRAM 1

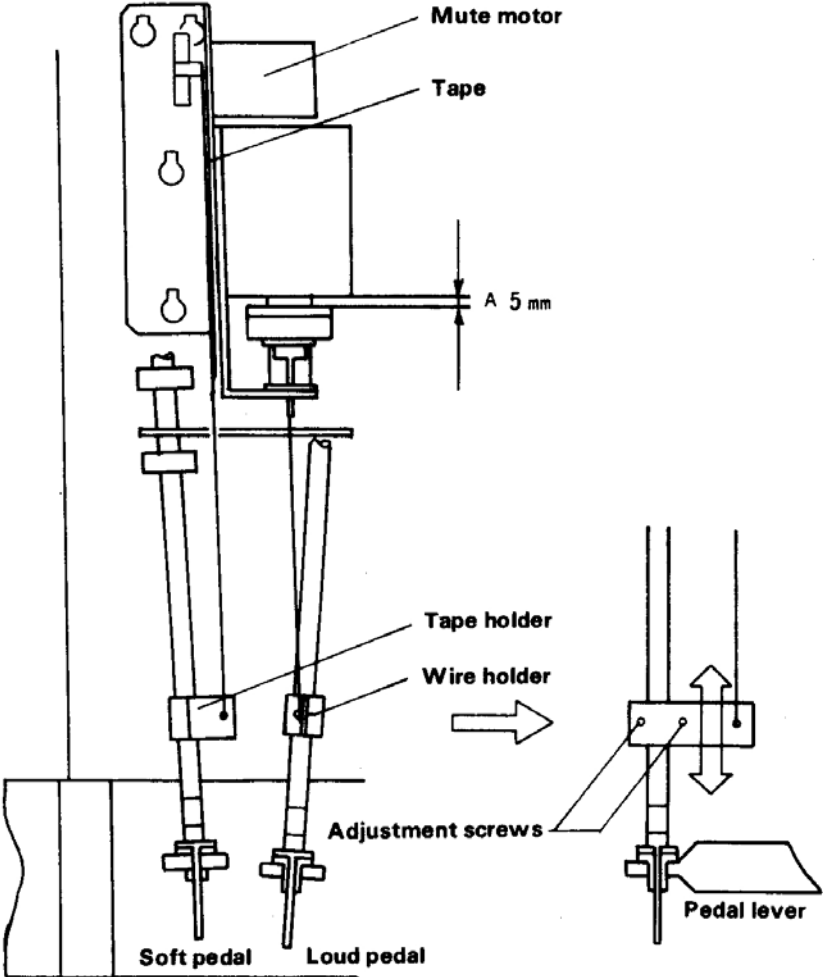

DIAGRAM 2

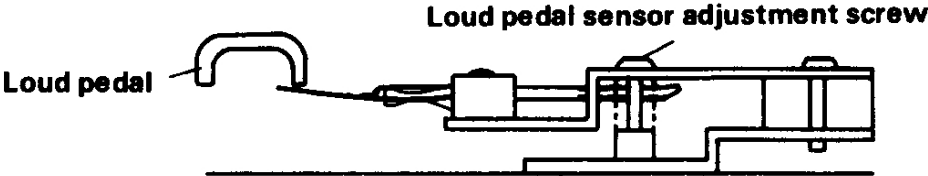

DIAGRAM 3

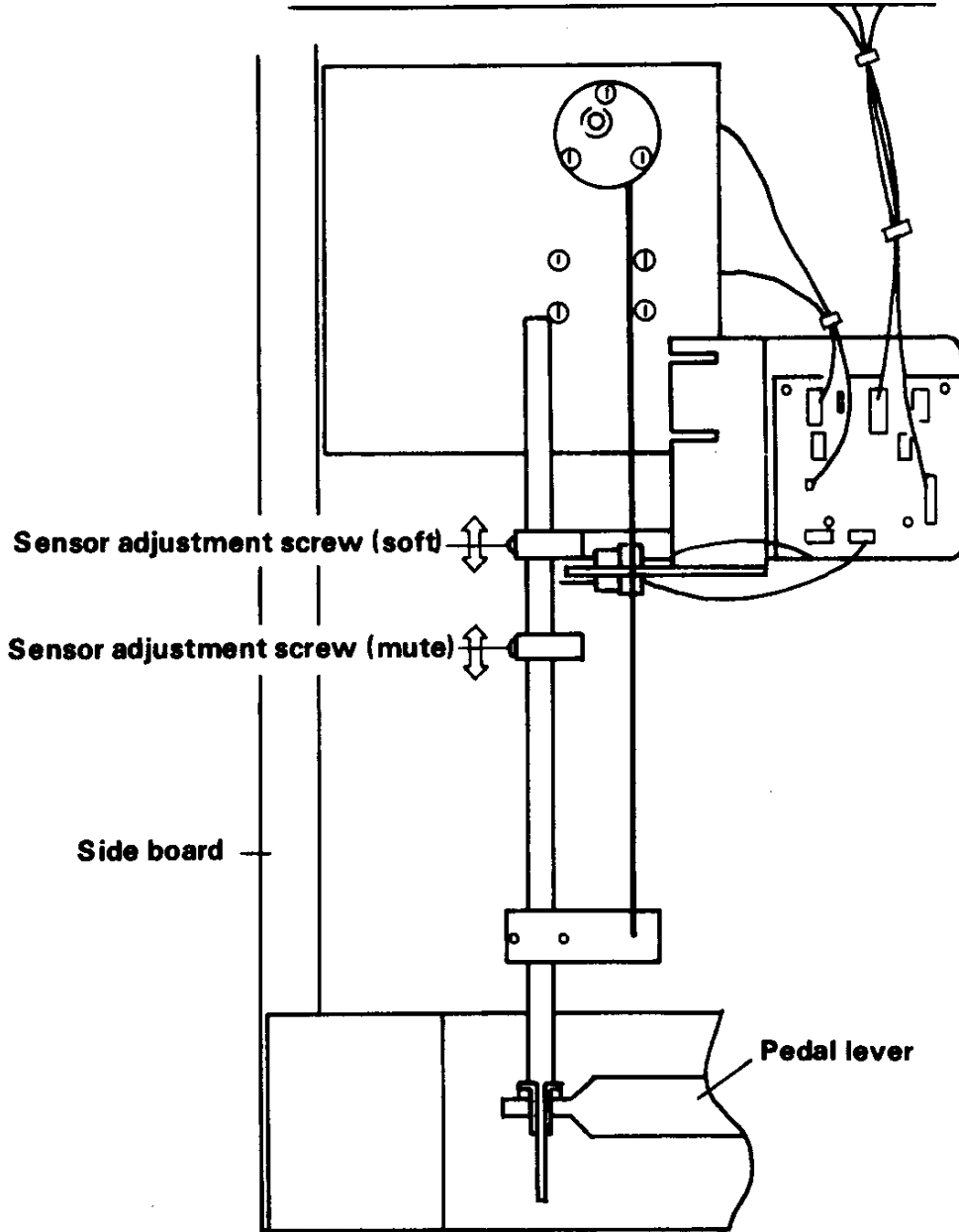
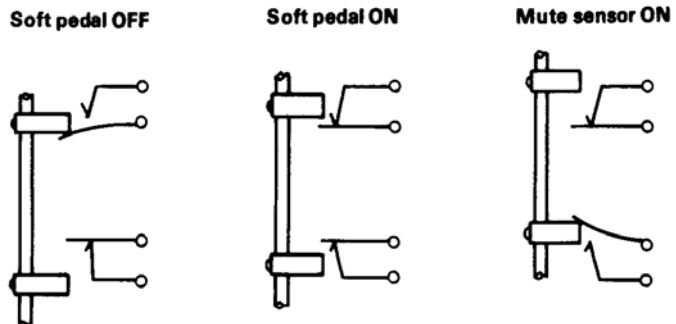

DIAGRAM 4







KEYDRIVE UNIT HEIGHT ADJUSTMENT

MX80 SERIES

PROCEDURE	RESULT	ADJUSTMENTS & COMMENTS
1. Remove the case parts.		This includes the top board, fallboard, and the 2 keystone rails.
2. Remove keys 1,57 and 88	Exposes the adjusting Phillips head screws used to raise or lower the keydrive unit.	There are 4 pairs of adjustment screws. The keydrive unit adjustment screws are located on the top side of the keydrive unit cover. They are the ones that are recessed in the cover.
3. Raise the keydrive unit height if the gap between the keydrive unit and keys is greater than 2mm.	.The gap between the keydrive unit and keys is 2mm. The keydrive unit must be parallel to the key.	<u>Turn the 2 adjustment screws in each section clockwise.</u> Note: If the keydrive unit is set too high, the keys will knock on the keydrive unit cover screws, and the hammers will be off of the hammer rest rail.
4. Lower the keydrive unit height if the gap between the keydrive unit and keys is less than 2mm.	The gap between the keydrive unit and the bottom of the keys is 1 to 2mm. The keydrive unit must be parallel to the key.	<u>Turn the 2 adjustment screws in each section counter-clockwise.</u> Note: If the keydrive unit is set too low, the solenoids will knock under the keys, and will cause the hammers to double strike when the Disklavier system plays the piano.



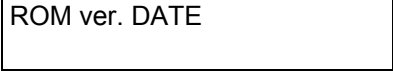

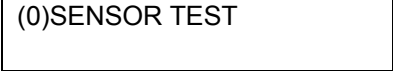









KEY SENSOR TEST

MX80 SERIES

PROCEDURE	RESULT	ADJUSTMENTS & COMMENTS
1. Remove keys #1, 23, 24, 45, 46, 66, 67, & 87	By removing these keys, the 2 sensor adjusting screws are made accessible at each of the locations.	
2. While pressing the  and  buttons, press the  button.	LCD will display: 	
3. Press the  button.	LCD will display 	
4. Slowly press a white key near the adjusting screw until the first beep is heard.	When the first beep is heard, top of key should be approx. 2.5mm below top of adjoining key and hammer tail should be approx. 7mm forward of adjacent hammer. As the key is depressed slowly in test mode, four different beeps, one at each detecting point, will be heard (at approximately 2mm increments). After the last beep is heard, the key should travel approximately 2mm further before contacting the front rail.	If sensor detect beep is not sounded at 2.5mm, it is an indication that the sensor rail is too low. There are 8 adjustment screws, one on the front side of the rail, one on the back (at each adjusting position). To raise the rail: Loosen the appropriate adjustment screw(s) ½ turn. Recheck and repeat if necessary. If sensor detect beep sounds before 2.5mm is reached, it is an indication that the sensor rail is too high. To lower the key sensor rail: Tighten the appropriate adjustment screw(s) ½ turn. Recheck and repeat if necessary. After final adjustment, tension should be the same on both screws and the sensor rail should be parallel to the bottom of the key (when key is depressed) NOTE: When key is depressed approximately 2.5mm notice that there is about 1mm of exposed wood visible on the side of the neighboring key.
5. Slowly press the key all the way down	Verify that: Four different sounds are heard; The fourth sound starts approx. 1.5mm before key touches front rail punching.	If the last beep is heard too close to the bottom of key travel, or not at all, do step 4 again.







KEYBOARD TRIMMER SETTING AND ADJUSTMENT All Key & Pedal

MX80 SERIES

PROCEDURE	RESULT	ADJUSTMENTS & COMMENTS
1. While pressing the  and  buttons, press the  button.	LCD will display: <div style="border: 1px solid black; padding: 2px; width: fit-content;">ROM version & Date of ROM</div>	
2. Press the  button.	LCD will display: <div style="border: 1px solid black; padding: 2px; width: fit-content;">I/O TEST ROM ver. & Date of ROM</div>	
3. Press the  button 3 times.	LCD will display: <div style="border: 1px solid black; padding: 2px; width: fit-content;">TRIMMER<PLY>OK (0)<-0</div>	Keys will start to play. This is the global trimmer adjustment. Normally, the factory setting of 0 is OK. To increase the volume, press the  button. To decrease the volume, press the  button. The range is from -5 to +5. Press the  button to store, then press the  button.
4. Press the  button.	LCD will display: <div style="border: 1px solid black; padding: 2px; width: fit-content;">PEDAL TRIMMER (0)<-0</div>	A chord will be played and the dampers will move away from the strings. To increase damper lift, press the  button. To decrease the damper lift, press the  button. The range is from -5 to +5. Press the  button to store, then press the  button.
5. Press the  button.	Turn off the DKV.	















KEYBOARD MEASUREMENT

MX80 SERIES

PROCEDURE	RESULT	ADJUSTMENTS & COMMENTS
1. While pressing the  and  buttons, press the  button.	LCD will display: <div style="border: 1px solid black; padding: 2px;">ROM version & Date of ROM</div>	
2. Press the  button 2 times.	LCD will display: <div style="border: 1px solid black; padding: 2px;">I/O TEST ROM ver. & Date of ROM</div>	
3. Press the  and c buttons at the same time.	LCD will display: <div style="border: 1px solid black; padding: 2px;">KEY TRIMMER xxk (+/-x)</div>	xxk represents the key number, (+/-x) represents the trimmer value for that key.
4. Press the  button.	LCD will display: <div style="border: 1px solid black; padding: 2px;">AUTO KEY TRIMMER xxk (+/-x)</div> Then: <div style="border: 1px solid black; padding: 2px;">WAIT Xxxxx</div> After the third display, the LCD will go blank.	Note 1 through 88 will play three times. < This display will repeat itself 3 times. xxxxx represents a countdown display.
5. Press the  button.	Turn the DKV off.	











KEYBOARD ADJUSTMENT

MX80 SERIES

PROCEDURE	RESULT	ADJUSTMENTS & COMMENTS
1. While pressing the  and  buttons, press the  button.	LCD will display: ROM version & Date of ROM	
2. Press the  button 2 times.	LCD will display: I/O TEST ROM ver.& Date of ROM	
3. Press the  and  buttons at the same time.	LCD will display: KEY TRIMMER xxk (+/-x)	Notes will begin to play chromatically. Listen for evenness of volume. When unevenness is heard, It is necessary to press the  button as the note you want to change is being played. To accomplish this, position your finger over the  button. Play the key you want to change and immediately press the  button. The uneven note and the note above will begin to play. To change the value of the lower note: 4. Press the  button to raise the volume; Press the  button to lower volume. 5. Press the  button to save the change.
4. Press the  button.	Notes will begin to play chromatically again.	The  button is used to toggle between the play function and the calibrate function.
5. Continue to check for evenness from note to note.		Play a note several notes below the one you want to change. The chromatic scale will resume from this point.
6. Press the  button.	Turn off the power to end this mode.	

CONTROL UNIT TESTING

MX80 SERIES

Operation	Content of test
1. While pressing and holding the  and  buttons, press the power button.	Shows ROM Version
2. Press 	7 seg and LED test
3. Press 	LCD test
4. Press 	Buzzer test
5. Press 	Switch and Remote Controller test
6. Press 	RAM test
7. Press 	ROM test
8. Press 	MIDI test <ul style="list-style-type: none"> • Connect one end of a MIDI cable to the MIDI IN port and the other end of the same MIDI cable to the MIDI OUT port. • This creates a loop which will test MIDI send and receive functions.
9. Press 	Piano test (chromatic scale)
10. Press  (Don't perform this test, it erases the disk!)	FDD test