

# disklavier

SERVICE MANUAL

# MX80

MX80

## ■ CONTENTS

The Disklavier MX80 Design	2
Panel Layout	3
How to Format Disks	4
MIDI Block Diagram	5
MIDI Implementation Chart	6
Functions of each Unit	7
Unit Wiring	8
Adjustment of each Unit	9
Test Program	11
Disassembly Procedure of Electrical Unit	18
Trouble Shooting by LED on I/O Board	21
Circuit Boards	22
Parts List	
Overall Circuit Diagram	

## IMPORTANT NOTICE

This manual has been provided for the use of authorized Yamaha Retailers and their service personnel. It has been assumed that basic service procedures inherent to the industry, and more specifically Yamaha Products, are already known and understood by the users, and have therefore not been restated.

**WARNING:** Failure to follow appropriate service and safety procedures when servicing this product may result in personal injury, destruction of expensive components and failure of the product to perform as specified. For these reasons, we advise all Yamaha product owners that all service required should be performed by an authorized Yamaha Retailer or the appointed service representative.

**IMPORTANT:** The presentation or sale of this manual to any individual or firm does not constitute authorization, certification, recognition of any applicable technical capabilities, or establish a principle-agent relationship of any form.

The data provided is believed to be accurate and applicable to the unit(s) indicated on the cover. The research, engineering, and service departments of Yamaha are continually striving to improve Yamaha products. Modifications are, therefore, inevitable and changes in specification are subject to change without notice or obligation to retrofit. Should any discrepancy appear to exist, please contact the distributor's Service Division.

**WARNING:** Static discharges can destroy expensive components. Discharge any static electricity your body may have accumulated by grounding yourself to the ground buss in the unit (heavy gauge black wires connect to this buss).

**IMPORTANT:** Turn the unit OFF during disassembly and parts replacement. Recheck all work before you apply power to the unit.

# The Disklavier Design

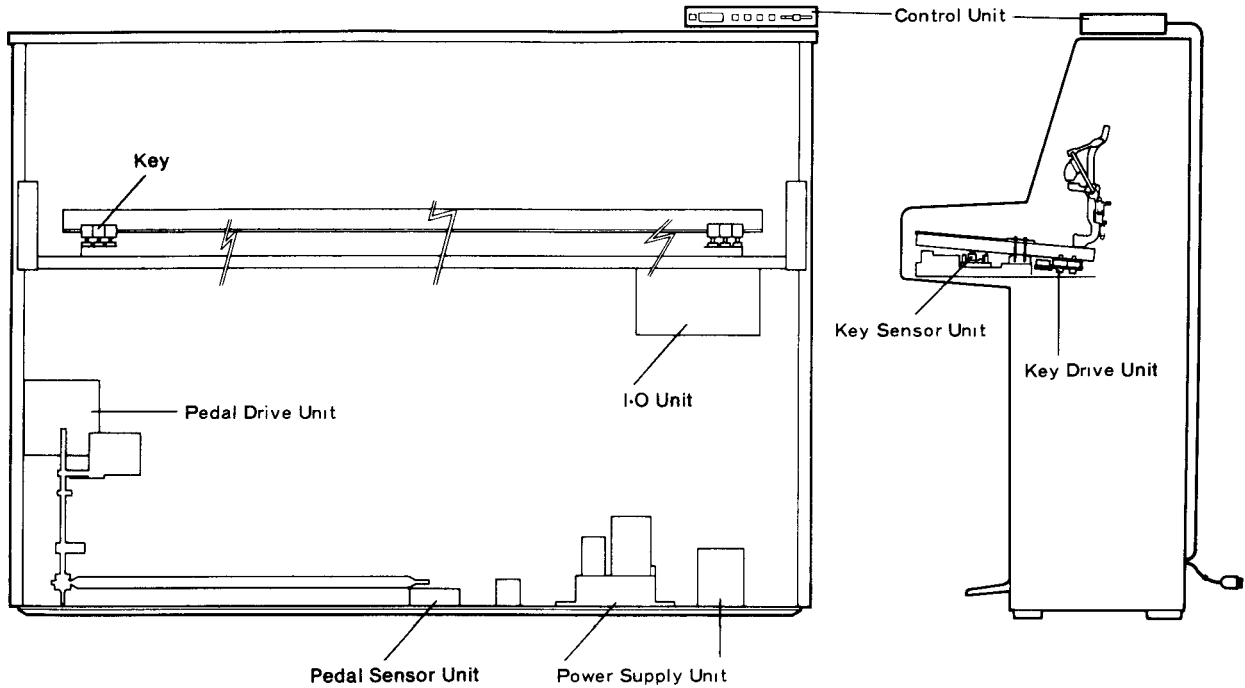

## Specifications

### Design

Control unit	<ul style="list-style-type: none"> <li>• Dimensions</li> <li>• Panel buttons</li> <li>• LCD</li> <li>• LED display</li> <li>• Disk drive</li> <li>• Jacks</li> <li>• Media</li> </ul>	<p>W 43.5 cm (17.1 in)                  D 19.2 cm ( 7.6 in)                  H 4.7 cm ( 1.9 in)</p> <p>7 (Power, Volume, Record, Stop, Forward, Reverse, Play/Pause)</p> <p>Dot matrix (16 characters x 2 lines)</p> <p>7 segments x 2 digits</p> <p>3.5 inch micro-floppy disk drive</p> <p>MIDI IN/OUT</p> <p>Double sided, double density, double track</p> <p>3.5 inch microfloppy disks</p> <p>Memory capacity: 628 kbytes</p> <p>Number of pieces: 60</p> <p>Music titles: 32 characters</p> <p>Disk titles: 64 characters</p>
Sensor Unit	<ul style="list-style-type: none"> <li>• Polyphonic voices</li> <li>• Key sensor</li> </ul>	<p>16</p> <p>88 keys</p> <p>Max number of notes at a time: 16 notes</p> <p>Sustain pedal</p>
Drive Unit	<ul style="list-style-type: none"> <li>• Pedal sensor</li> <li>• Polyphonic voices</li> <li>• Key drive</li> <li>• Pedal drive</li> </ul>	<p>16</p> <p>88 keys</p> <p>Max number of notes at a time 16 notes</p> <p>Sustain pedal</p>
Power supply	<ul style="list-style-type: none"> <li>• Power requirement</li> <li>• Ambient temperature</li> </ul>	<p>Local AC voltage</p> <p>4°C (40°F) ~ 40°C (104°F)</p>

### Standard equipment

- Wireless remote control unit
- Prerecorded floppy disk
- Blank floppy disk

\* Specifications and exterior design are subject to change without notice.

# Panel Layout

## Front Panel

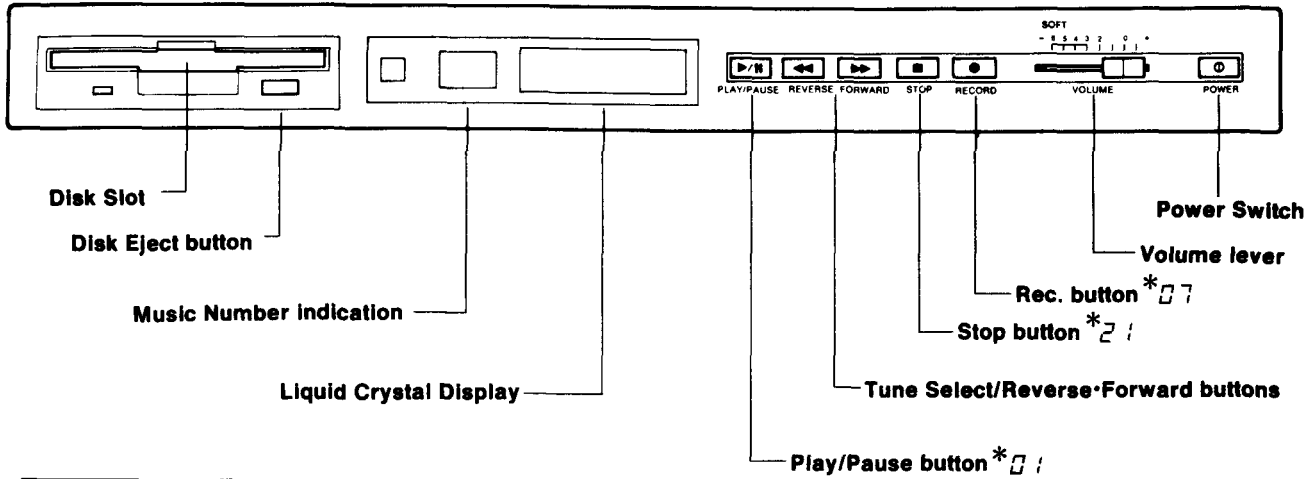

## Rear Panel

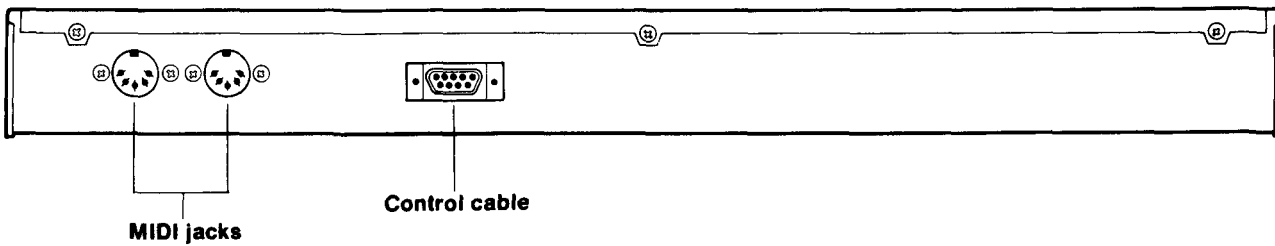

## Remote Control Unit

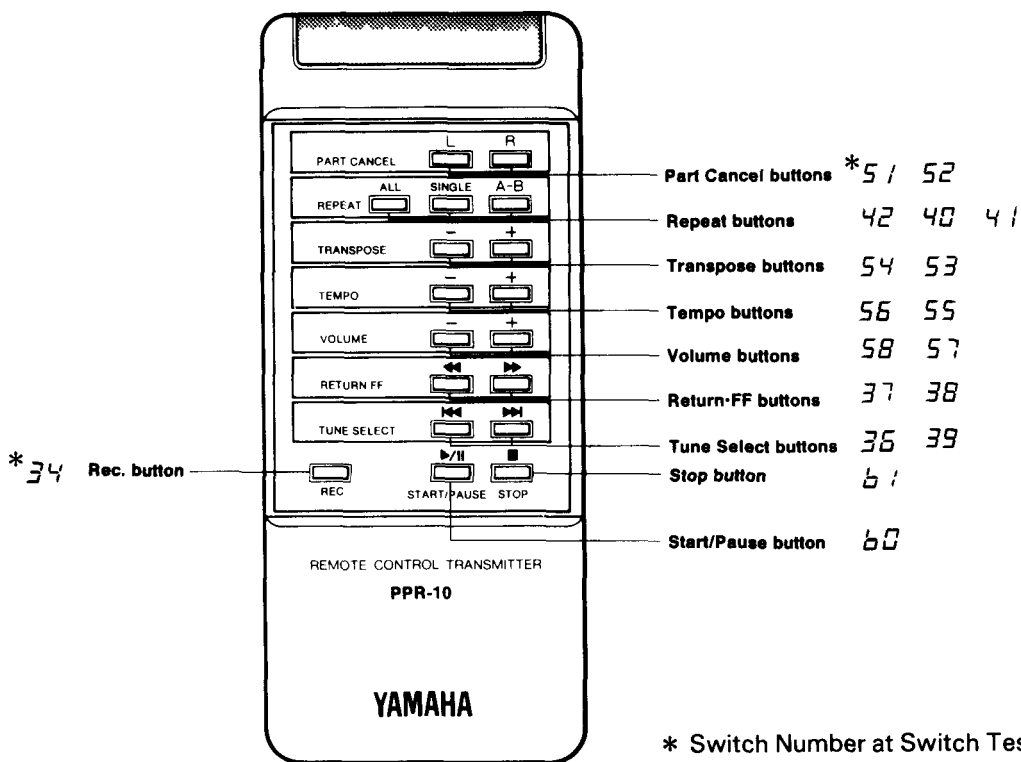

\* Switch Number at Switch Test (Refer Page 12)

## How to Format Disks

In order to be able to use newly purchased disks with the Disklavier, they first have to be "formatted". It is not necessary to format the supplied pre-recorded disk and Piano Soft™ disks for Disklavier. (Doing so would erase the recorded music!)

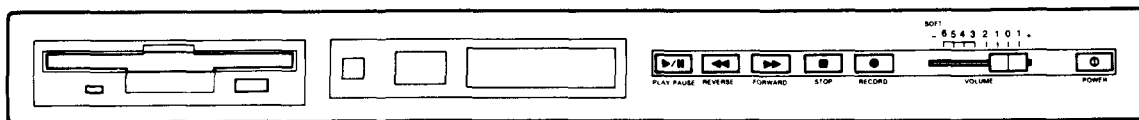

**1**

Insert the floppy disk.

UNFORMATTED DISK

**2**

After inserting a disk, press the Rec. button while keeping the Stop button depressed. You can release these buttons when the display reads "FORMAT OK?".

FORMAT OK?

**3**

In answer to the above message, press the Play/Pause button.

FORMAT OK??

**4**

Reconfirm the above question by again pressing the Play/Pause button.

FORMATTING NOW!

**5**

After a few minutes, formatting is completed and the display will change as follows.

If you decide not to proceed with formatting, press the stop button when the display shows "FORMAT OK?" or "FORMAT OK??".

## MIDI Block Diagram

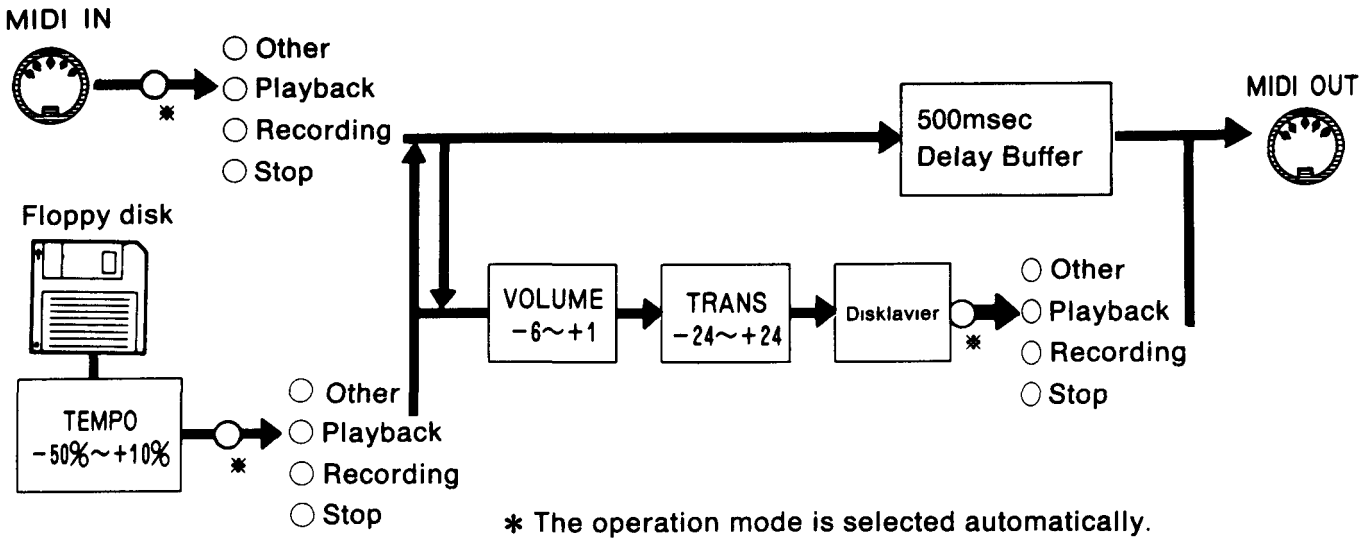

### Timing adjustment and MIDI OUT 500msec delay buffer

It takes the Disklavier 500msec to produce a sound from the input of the data into the MIDI IN terminal. This function is used to set the interval between the start of the key action and actual sound to 500msec.

When an external MIDI instrument is connected to the MIDI OUT of the Disklavier, it is necessary to set the delay to 500msec. For this purpose, the MIDI OUT delay buffer is set to 500msec. MIDI IN timing is always set to DELAY IN during playback.

### Relation of Input/Output Switching for Each Operation and 500 msec Delay Buffer

Operation	IN	OUT	500 msec Delay
Playback	x	O	ON
Recording	x	O	OFF
Stop	O	O	ON

- O: Transmission enabled
- x: Transmission disabled
- ON: 500 msec delay
- OFF: No 500 msec delay

# MIDI Implementation Chart

[DISKLAVIER]

Model MX80 MIDI Implementation Chart

Date: 89.12.15  
Version: V1.o

Function		Transmitted	Recognized	Remarks
Basic Channel	Default Changed	1 O (1-2)	1 x	L/R hand
Mode	Default Messages Altered	3 x * * * * *	3 x x	
Note Number:	True voice	21-108 * * * * *	21-108 21-108	
Velocity	Note ON Note OFF	O 9nH,V = 1-127 x 9nH, V = 0 *1	O V = 1-127 O	
After Touch	Key's Ch's	x x *1	x x	
Pitch Bend		x *1	x	
Control Change	64 67	O O  *1	O O	
Prog Change	: True#	x * * * * * *1	x	
System Exclusive		x *1	x	
Common	Song Pos Song Sel Tune	x x x	x x x	
System Real Time	Clock Commands	x x	x x	
Aux Messages	Local ON/OFF All Notes OFF Active Sense Reset	x x O x	x O O x	
Notes	All recognized data are transmitted 500msec later if controller mode is STOP or PLAY. *1 All data are enabled to transmitted as record data if other E-seq disk is used and mode is PLAY.			

MX80

Mode 1: OMNI ON. POLY      Mode 2: OMNI ON. MONO      O: Yes  
Mode 3: OMNI OFF. POLY      Mode 4: OMNI OFF. MONO      x: No

## ■ Functions of each Unit

### <Control unit>

- **Control of overall operations**

The control board controls all operations.

The control panel consists of the various operation buttons, a 7-segment LED (song number display), and an LCD (liquid crystal display).

- **Playback system**

The FDD (floppy disk drive) reads data (Yamaha E-seq format) from the FD (floppy disk), the control board converts it into MIDI data, and transmits it to the I/O unit. (The MX80 uses MIDI messages to transfer data between the control unit and the I/O unit.)

- **Recording system**

This converts the MIDI data from the I/O unit into Disklavier recording data, sends it to the FDD, and records it on the FD.

### < I/O board >

- **Playback system**

This converts the MIDI messages from the control unit into Disklavier operation data, and sends it to the drive unit. This section manages data for the drive unit, (drive table, all-key trimmer, individual key trimmers, pedal trimmer)

- **Recording system**

This converts the signals from the sensor unit into MIDI data, and sends them to the control unit.

- **Power supply relay**

This relays the power supply sent from the power supply unit to the control unit, sensor unit, and mute unit.

### <Drive unit>

- **Key drive unit**

This operates the solenoids according to the keyboard drive data from the I/O board, moving the keys for playback.

- **Pedal drive unit**

This operates the solenoids according to the pedal drive data from the I/O board, moving the pedal rod to raise the loud pedal, playing back the loud pedal effect. (The soft pedal is not played back. Nor does the loud pedal itself move.)

- **Supply and relay power and data**

Power is supplied to the key drive from the power supply unit.

Playback data is received from the I/O unit. Power and data are supplied to the pedal drive via the key drive.

### <Mute unit>

- **Functions and operation**

When the volume is adjusted into mute mode (-3 ~ -6), a motor will operate to move the soft pedal lifting rod, shortening the striking distance of the hammer action. This shortening of the hammer striking distance improves the striking efficiency, allowing soft notes to be played back reliably. The mute mode will be cancelled when the power is turned off or during recording operations.

### <Sensor unit>

- **Key sensor**

An optical sensor detects key movements at four points. The detected data is recorded as note timing, hammer speed, and note off timing, just as in the MX 100A.

- **Pedal sensor**

This detects pedaling for both the loud and soft pedals, using a leaf sensor.

### < Power supply unit>

This supplies power to the various units.

### < Connectors >

- **MIDI IN**
- **MIDI OUT**

# Unit Wiring

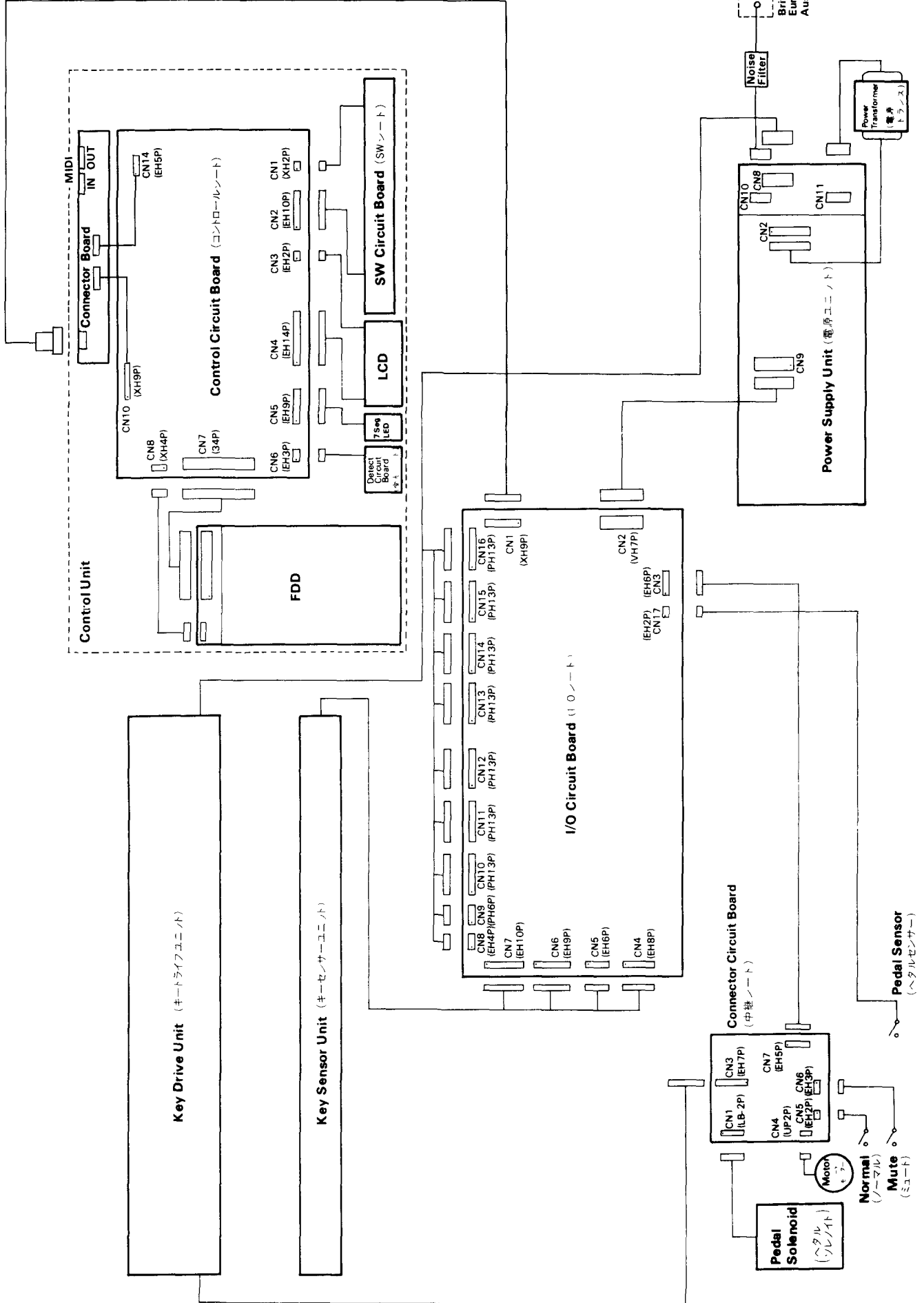

**MX80**

## ■ Adjustment of each Unit

### 1. Adjusting the key drive unit

#### [ Height adjustment ]

Adjust the gap between the lower surface of the key and the upper surface of the key drive unit to a distance of 2.0~2.5 mm.

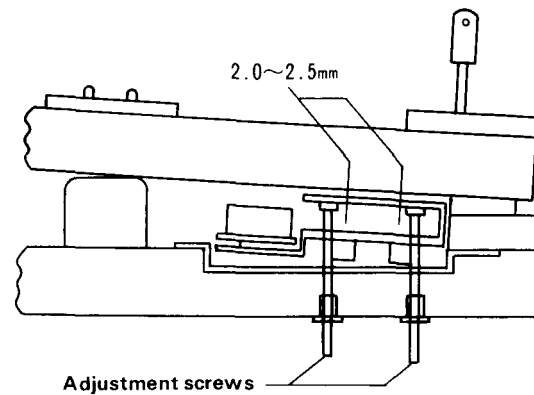

### 2. Adjusting the keyboard holder

#### [ Loud pedal/stroke adjustment ]

- ① Perform normal pedal adjustments.
- ② Adjust the stroke for automatic playback.
  - 1) Adjust the fixed position of the wire holder so that A is 5 mm.
  - 2) Make sure that during automatic playback, when the loud pedal is on, the damper wood is 2.5 mm  $\pm$  0.5 from the note off position.

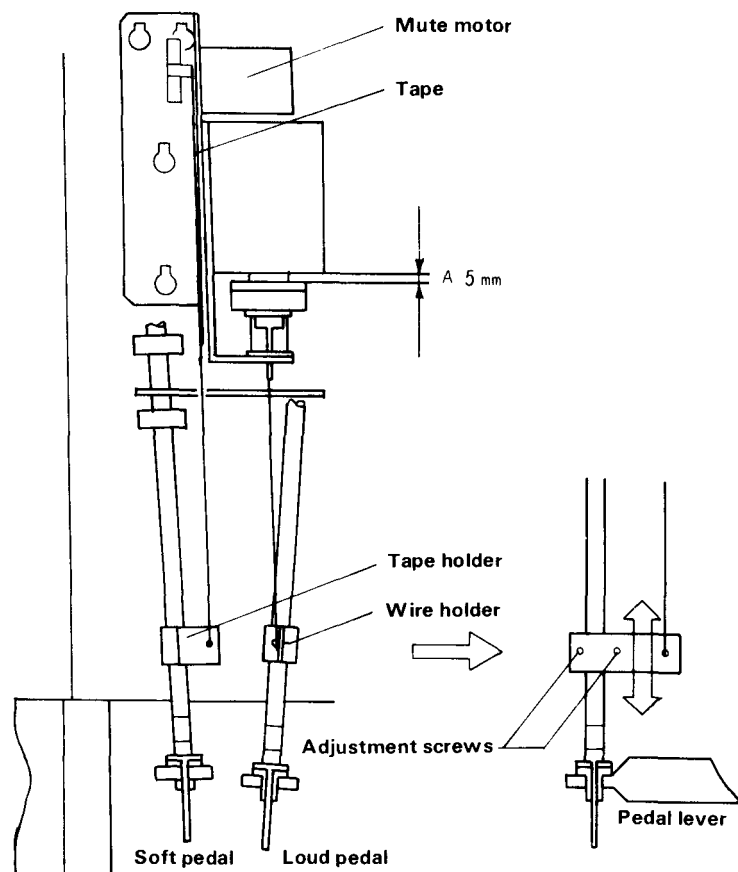

### 3. Adjusting the mute unit windup tape

#### [ Tape tension adjustment ]

Adjust the tape holder to a position where the tape is not excessively loose or tight when the mute is off, and fasten it in place.

**4. Adjusting the key sensors**

**[ Key sensor height adjustment ]**

Use the sensor test of the test program to adjust the sensor height.

- ① Adjust the M1 ON position to 2.5 mm +/-0.5.
- ② Press the keyboard further, and check that M4 is definitely ON.

\* Changes in the buzzer sound will allow you to confirm that M1, 2, 3, and 4 are being detected correctly.

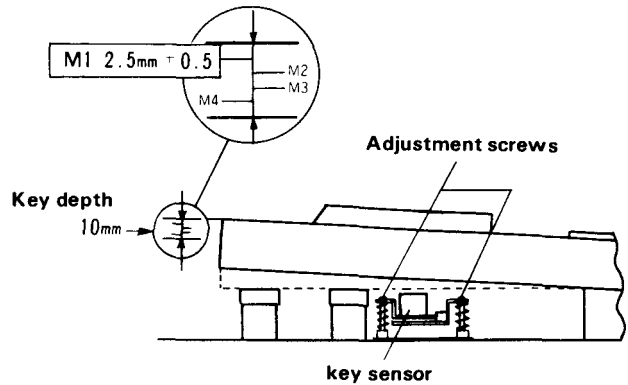

**5. Adjusting the pedal sensor**

As in step 5, use the sensor test of the test program to adjust the sensor height.

**[ Loud pedal sensor ]**

- ① Make adjustments so that when you gradually press the loud pedal, the pedal sensor turns on when the damper wood moves 1.5 mm +/- 0.5.
- ② Confirm by recording and playing back.

**[ Soft pedal sensor ]**

- ① Make adjustments so that as you gradually press the soft pedal, the pedal sensor turns on when the hammer rail moves 2~3 mm.
- ② Confirm by recording and playing back.

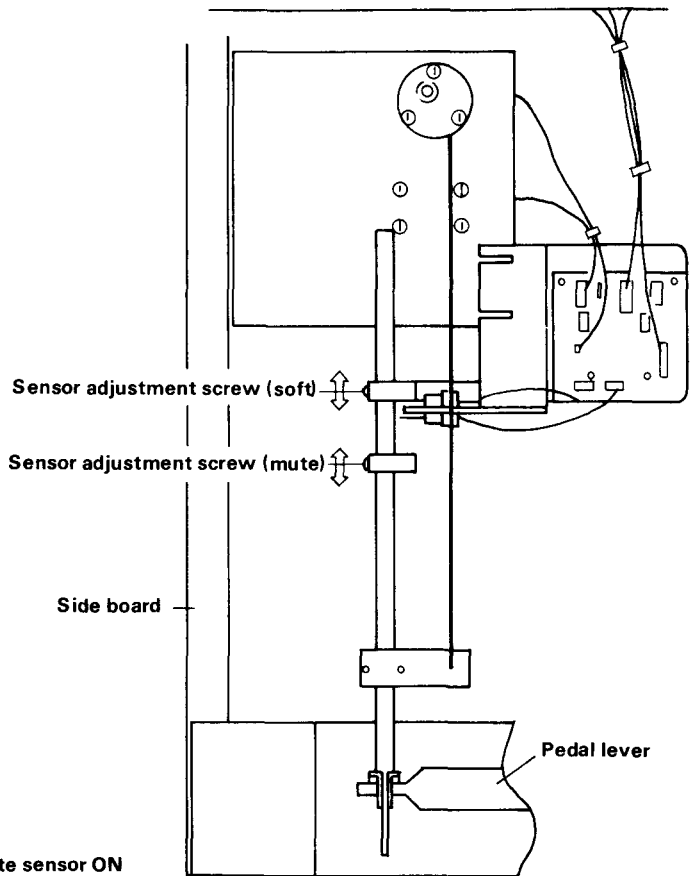
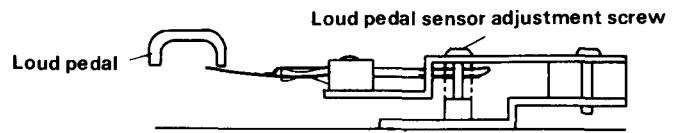

**6. Adjusting the mute sensor**

Perform volume adjustments in the stopped condition, and set the mute mode to [ VOLUME-3 MUTE ]. Adjust the mute sensor so that the hammer blow distance is 1.6 mm +/- 3 in mute mode.

Soft pedal OFF

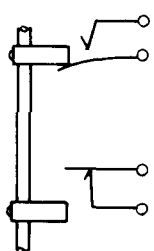

Soft pedal ON

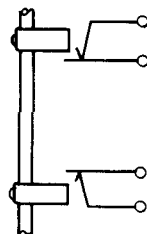

Mute sensor ON

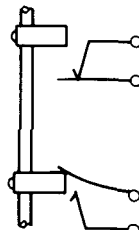

# Test Program

## <Test program flow chart >

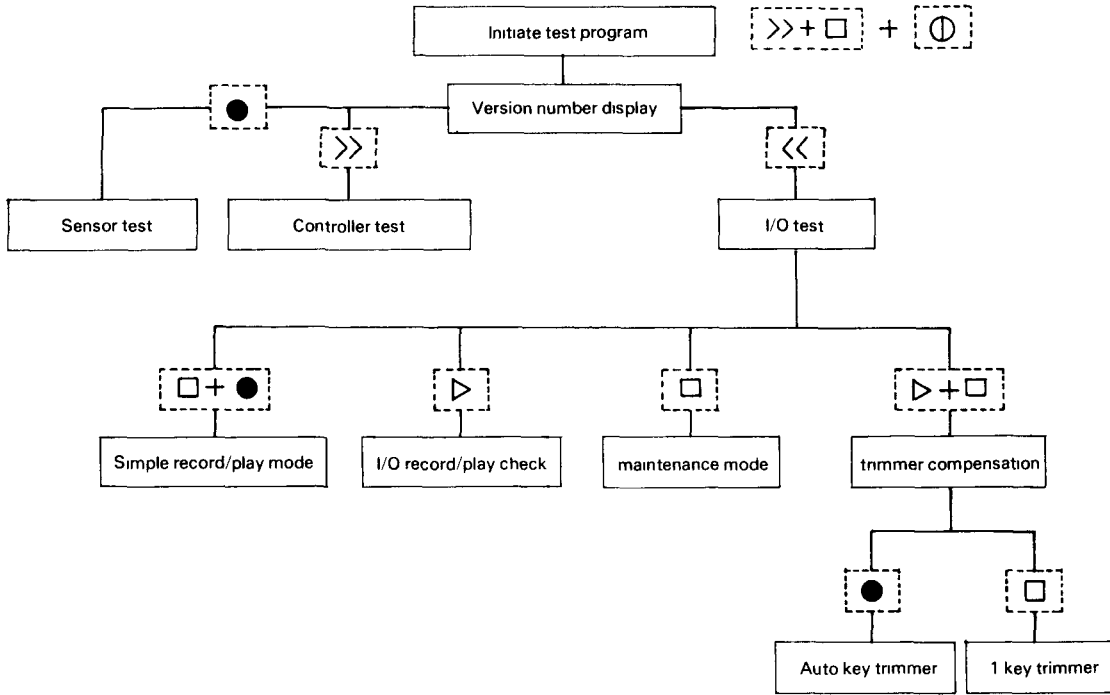

### Operation buttons

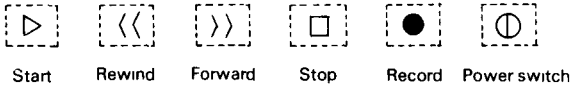

## < Outline of each test >













	Controller test	Sensor test	I/O test				
			I/O record/ playback check	Maintenance mode	Auto key trimmer	Each key trimmer	Simple record/ play
<b>Outline of test</b>	• Check controller functions (same as MX test program)	• Sensor adjustment	• Operational check of each solenoid/sensor	• Determine model type (rec&play or play-only) • Display accumulated playing time • Adjust all-key trimmer • Adjust pedal trimmer	• Automatic key trimmer compensation	• Each key trimmer compensation	• Record/play (FD not used)
<b>Test items</b>	• 7seg & LED • LCD • BUZZER • SW • RAM • ROM • MIDI • PIANO (• FDD)	• Key sensor position • Pedal	• SCALE p-S • SCALE p-F • SCALE f-S • SCALE f-F • SCALE 5Hz • PEDAL t-1 • PEDAL t-2 • JESUS	Same as above	Same as above	Same as above	Same as above

For details of each test, refer to pages 12~17

Controller test

Check controller functions

MX80

	Item	Operation	Display / test contents
①	Initiate test program	Remove disk Turn power on while holding  + 	<div style="border: 1px solid black; padding: 5px; display: inline-block;">V1. 1C 900303</div> <ul style="list-style-type: none"> <li>• Check the ROM version number of the controller</li> </ul>
②	1 7-segment LED test	Press 	<div style="border: 1px solid black; padding: 5px; display: inline-block;">11</div> (1) 7SEG & LED TEST ↓ 00, 11 ~ 99 <ul style="list-style-type: none"> <li>• Check that the LED lights (00, 11 ~ 99)</li> </ul>
	2 LCD test	Press 	<div style="border: 1px solid black; padding: 5px; display: inline-block;">(2) LCD TEST ***** *****</div> <ul style="list-style-type: none"> <li>• Check the checkered pattern in the LCD display</li> </ul>
	3 Buzzer test	Press 	<div style="border: 1px solid black; padding: 5px; display: inline-block;">(3) BUZZER TEST EXECUTE!!</div> <ul style="list-style-type: none"> <li>• Check that the buzzer sounds while EXECUTE!! blinks</li> </ul>
	4 Switch test	Press 	<div style="border: 1px solid black; padding: 5px; display: inline-block;">01</div> (4) SW TEST (Panel & Remocon) <ul style="list-style-type: none"> <li>• Check the switch numbers of each button on the control panel and remote control (Refer page 3)</li> </ul>
	5 RAM test	Press 	<div style="border: 1px solid black; padding: 5px; display: inline-block;">(5) RAM TEST OK!</div> <ul style="list-style-type: none"> <li>• Check whether RAM is OK or NG</li> </ul>
	6 ROM test	Press 	<div style="border: 1px solid black; padding: 5px; display: inline-block;">(6) ROM TEST OK!</div> <ul style="list-style-type: none"> <li>• Check whether ROM is OK or NG</li> </ul>
	7 MIDI test	* Use a cable to connect MIDI IN/OUT * Disconnect the cable Press 	<div style="border: 1px solid black; padding: 5px; display: inline-block;">(7) MIDI TEST OK!</div> <ul style="list-style-type: none"> <li>• Check whether MIDI is OK or NG</li> <li>• NG is displayed when a MIDI cable is not connected</li> </ul>
	8 Piano test	Press 	<div style="border: 1px solid black; padding: 5px; display: inline-block;">01</div> (8) PIANO TEST VELOCITY = **** ↓ 01 ~ 88 <ul style="list-style-type: none"> <li>• Playback test keys 1 ~ 88</li> <li>• Recording test key number is displayed simultaneously with the above playback</li> </ul>
	(9 FDD test) * Execute the FDD test only when necessary	* Insert a FD (formatted) Press  Press 	<div style="border: 1px solid black; padding: 5px; display: inline-block;">(9) FDD TEST</div> <div style="border: 1px solid black; padding: 5px; display: inline-block;">CHECK THE DISK PUSH [START]</div> <div style="border: 1px solid black; padding: 5px; display: inline-block;">(9) FDD TEST TRK00,SID0,SECT1</div>
③	End test	Power off	

MX80

To return to the previous test, press .

I/O record/play test

Check the operation of each solenoid

	Item	Operation	Display / test contents
①	Initiate test program	Remove disk Turn power on while holding	<div style="border: 1px solid black; padding: 2px; display: inline-block;">V1. 1C 900303</div> <ul style="list-style-type: none"> <li>• Check the ROM version number of the controller</li> </ul>
		Press	
②	Initiate the I/O test	Press	<div style="border: 1px solid black; padding: 2px; display: inline-block;">I O TEST V1. 1E 89.6.16</div> <ul style="list-style-type: none"> <li>• Check the ROM version number of the I/O board</li> </ul>
	Contents of each test 1 Soft strike / slow scale	Press	<div style="border: 1px solid black; padding: 2px; display: inline-block;">SCALE piano-S</div> Volume piano Tempo S = slow key = ** vel = ** ** = No / numerical value
		Press	<ul style="list-style-type: none"> <li>• Check scale playback / operation</li> </ul>
	2 Soft strike / fast scale	Press	<div style="border: 1px solid black; padding: 2px; display: inline-block;">SCALE piano-F</div> Volume piano Tempo F = fast
		Press	<ul style="list-style-type: none"> <li>• Check scale playback / operation</li> </ul>
	3 Strong strike / slow scale	Press	<div style="border: 1px solid black; padding: 2px; display: inline-block;">SCALE forte-S</div> Volume forte Tempo S = slow
		Press	<ul style="list-style-type: none"> <li>• Check scale playback / operation</li> </ul>
	4 Strong strike / fast scale	Press	<div style="border: 1px solid black; padding: 2px; display: inline-block;">SCALE forte-F</div> Volume forte Tempo F = fast
		Press	<ul style="list-style-type: none"> <li>• Check scale playback / operation</li> </ul>
	5 Five repeated notes	Press	<div style="border: 1px solid black; padding: 2px; display: inline-block;">SCALE 5Hz</div> Five repeated note scale
Press		<ul style="list-style-type: none"> <li>• Check five-note scale / operation</li> </ul>	
6 Loud pedal test	Press	<div style="border: 1px solid black; padding: 2px; display: inline-block;">PEDAL test 1</div> 1) Chord + loud pedal ON 2) Chord + loud pedal OFF 3) Loud pedal ON/OFF	
	Press	<ul style="list-style-type: none"> <li>• Check loud pedal / operation</li> <li>• Adjust loud pedal / stroke</li> </ul>	
7 Loud pedal repetition test	Press	<div style="border: 1px solid black; padding: 2px; display: inline-block;">PEDAL test 2</div> Loud pedal repetitions	
	Press	<ul style="list-style-type: none"> <li>• Check loud pedal / operation</li> </ul>	
8 Overall test of playback system	Press	<div style="border: 1px solid black; padding: 2px; display: inline-block;">JESUS</div> Test playback of Bach's "JESU MEINE FREUDE"	
		<ul style="list-style-type: none"> <li>• Volume can be adjusted → check mute mode</li> <li>• Overall test of playback functions</li> </ul>	
③	End test	Power off	

MX80

**Maintenance mode**

Determine model type (display accumulated playback time / all-key trimmer / pedal)

**MX80**

	Item	Operation	Display / test contents
①	Initiate test program	Remove disk Turn power on while holding	V1. 1C 900303 • Check the ROM version number of the controller
		Press	
②	Initiate the I/O test		I/O TEST V1. 1E 89.6.16 • Check the ROM version number of the I/O board
	Contents of each test 1 Determine model type (rec&play)	Press	REC & PLAY model <STOP> NEXT TEST Record & playback model
		Press	
	2 Display accumulated playing time		TOTAL PLAY TIME 0001hour *****
	3 Adjust all-key trimmer		TRIMMER <PLY> OK  → temporary trimmer value UP (0) ← 0  → temporary trimmer value DOWN ↓ ↓  → execute trimmer setting → ( ) finalize value Trimmer value Temporary trimmer value * (0) is standard trimmer value • Check that the scale on keys 1~88 is played softly • Set trimmer values
Press			
4 Adjust pedal trimmer		PEDAL TRIMMER Procedure same as above (0) ← 0 • Set trimmer value	
③	End test	Power off	

Press to return 4 → 1

MX80











**Initializing trimmer values**

If you wish to set all key trimmers and pedal trimmers to their initial values.

then in the condition of test "1 Determine model type", press , and the trimmer values will be initialized (This will require approximately one minute)

Trimmers for each key



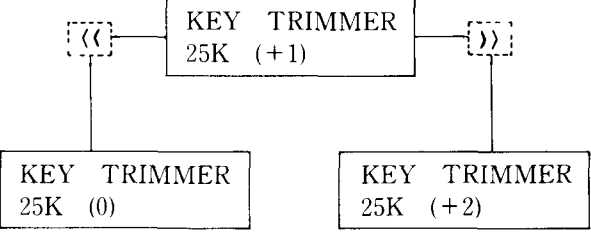

Manually adjust trimmer values for each key

	Item	Operation	Display / test contents
①	Initiate test program	Remove disk Turn power on while holding 	<div style="border: 1px solid black; padding: 5px; display: inline-block;">V1. 1C 900303</div> <ul style="list-style-type: none"> <li>• Check the ROM version number of the controller</li> </ul>
②	Initiate the I/O test  Contents of each test 1 Trimmer adjustments for each key	Press   Press 	<div style="border: 1px solid black; padding: 5px; display: inline-block;">I/O TEST V1. 1E 89.6.16</div> <p>Check the ROM version number of the I/O board</p> <div style="border: 1px solid black; padding: 5px; display: inline-block; margin-right: 20px;">KEY TRIMMER 01K (+5)</div> <div style="display: inline-block; vertical-align: top;"> <p>Keys 1~88 begin playing scale to re-start from key 1</p> <p>Press:  •</p> <p>"  move to auto-key trimmer</p> <p>"  switch to ascending scale</p> <p>"  switch to descending scale</p> <p>"  specify the key to adjust</p> </div> <p>Adjustment procedure</p> <ol style="list-style-type: none"> <li>1) While pressing the key you wish to adjust, press ; → The key to be adjusted will be played alternately with the next higher key (for example, key 25 key 25 ↔ 26)</li> <li>2) While comparing the two notes, use  to adjust the trimmer value of the key you wish to adjust</li> <li>3) Press  to finalize the trimmer value</li> </ol> <div style="text-align: center; margin-top: 20px;">  </div> <p>* If you manually press any desired key during the test, a scale will be played starting from that key</p>
③	End test	Power off	

MX80

**Auto key trimmer (only for record/ playback models)**





Automatic adjustment of trimmer values for each key

	Item	Operation	Display / test contents
①	Initiate test program	Remove disk. Turn power on while holding 	<div style="border: 1px solid black; padding: 5px; width: fit-content;">V1. 1C 900303</div> <ul style="list-style-type: none"> <li>• Check the ROM version number of the controller.</li> </ul>
②	Initiate the I/O test	Press 	<div style="border: 1px solid black; padding: 5px; width: fit-content;">I/O TEST V1. 1E 89.6.16</div> <ul style="list-style-type: none"> <li>• Check the ROM version number of the I/O board.</li> </ul>
	Contents of each test (1. Trimmer adjustments for each key)	Press 	<div style="border: 1px solid black; padding: 5px; width: fit-content;">KEY TRIMMER 01K (+5)    ⇨ to trimmer for each key</div>
	2. Automatic key trimmer adjustment	Press 	<div style="border: 1px solid black; padding: 5px; width: fit-content;">AUTO KEY TRIMMER 01K (+5)</div> <p style="text-align: center;">↓</p> <div style="border: 1px solid black; width: 100px; height: 30px; margin: 5px auto;"></div> <ul style="list-style-type: none"> <li>• Play triple-note scale on keys 1~88, and stop</li> <li>• Automatic measurement / calculate optimal trimmer values</li> <li>• End automatic key trimmer adjustment</li> </ul> <p>* If there is unevenness after automatic adjustment,</p> <ul style="list-style-type: none"> <li>• press  and repeat automatic adjustment or</li> <li>• manually adjust the trimmers of each key</li> </ul> <p>If automatic adjustment does not remove unevenness,</p> <ul style="list-style-type: none"> <li>• adjust, check, or repair key sensors / piano action</li> </ul>
③	Endtest	Power off	

MX80

**Simple record/playback mode**

Check record/playback functions between sensor and I/O (FD not used)

	Item	Operation	Display / test contents
①	Initiate test program	Remove disk. Turn power on while holding 	<div style="border: 1px solid black; padding: 5px; width: fit-content;">V1. 1C 900303</div> <ul style="list-style-type: none"> <li>• Check the ROM version number of the controller.</li> </ul>
②	Initiate the I/O test	Press: 	<div style="border: 1px solid black; padding: 5px; width: fit-content;">I/O TEST V1. 1E 89.6.16</div> <ul style="list-style-type: none"> <li>• Check the ROM version number of the I/O board.</li> </ul>
	Contents of each test 1. Simple record/playback test	Press   Press   Perform  Press 	<div style="border: 1px solid black; padding: 5px; width: fit-content;">REC &amp; PLAY test</div> <div style="border: 1px solid black; padding: 5px; width: fit-content; margin-top: 10px;">REC &amp; PLAY test record start</div> <div style="border: 1px solid black; padding: 5px; width: fit-content; margin-top: 10px;">31 38 3E 090709 key = ** vel = **</div> <ul style="list-style-type: none"> <li>• Recorded contents are displayed</li> <li>• Pedal sensor ON → buzzer sounds</li> </ul> <div style="border: 1px solid black; padding: 5px; width: fit-content; margin-top: 10px;">PLAY</div> <ul style="list-style-type: none"> <li>• Playback</li> </ul> <p>* Approximately 30 seconds can be recorded</p>
③	End test	Power off	The recorded contents will be erased.

MX80

# Disassembly Procedure of Electrical Unit

## 1. Control unit (figure 1)

Detach the cables from the rear panel.  
 Remove 7 screws, and the top cover will come off.  
 Double-faced tape is affixed to the sections marked by "\*" .

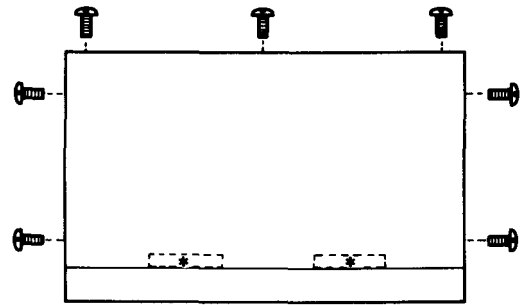

(Fig.1)

## 2. Control unit (figure 2)

Detach all connectors, and remove 6 screws.

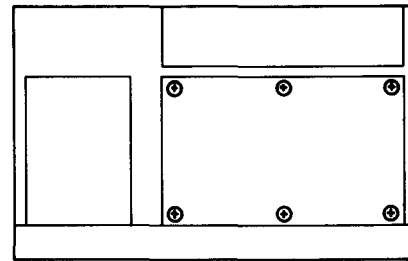

(Fig.2)

## 3. FDD (figure 3)

Detach 2 connectors, and remove 4 screws from the rear of the unit.

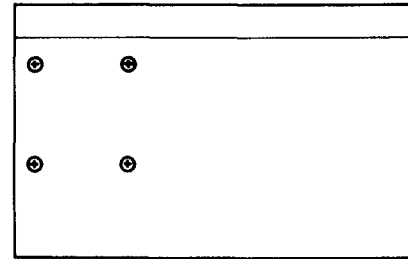

(Fig.3)

## 4. Key drive unit (figure 4)

Remove the entire keyboard.  
 Remove 9 connectors from the I/O board, detach the connector of the power supply unit, and detach the connector of the connector board. Remove screws ⑥ x 6.

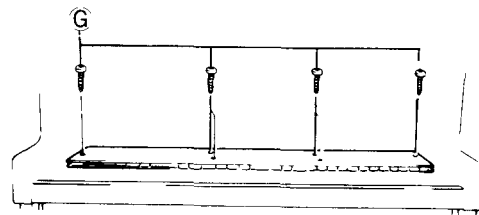

(Fig.4)

## Plunger (coil) assembly (figure 5)

Remove screws ⑨ x 19, and detach the drive board connector.

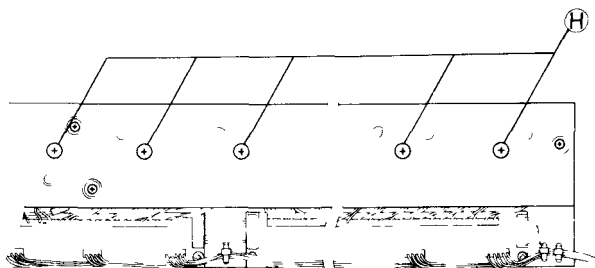

(Fig.5)

MX80

**5. Key sensor unit (figure 6)**

Detach 4 connectors from the I/O board. Remove screws ① x 8.

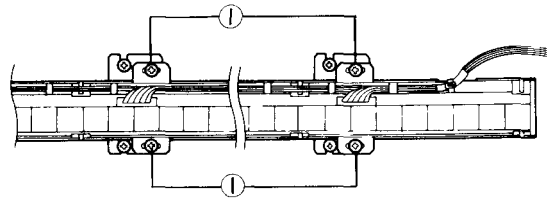

(Fig.6)

**6. Pedal drive unit (figure 7)**

**Pedal drive unit**

Remove the connector between the relay board and the I/O board.

Remove screws ④ and ⑤

Loosen and remove screws ⑥ x 4.

**Pedal solenoid**

Remove attaching screws x 4.

**Relay board**

Detach all connectors, and remove board holders x 4.

**Mute sensor**

Detach 2 connectors from the connector board

Loosen and remove screws ⑦ x 2.

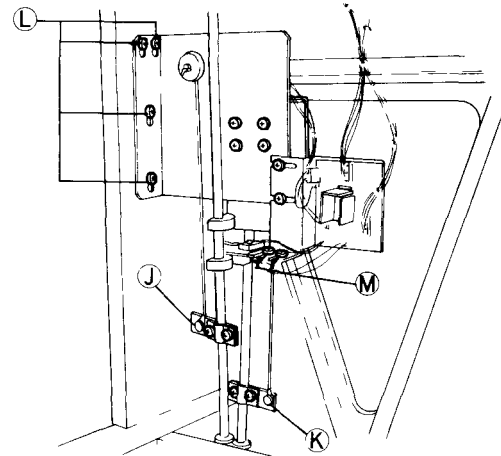

(Fig.7)

**7. I/O board (figure 8)**

Detach all connectors, and remove board attaching screws x 6.

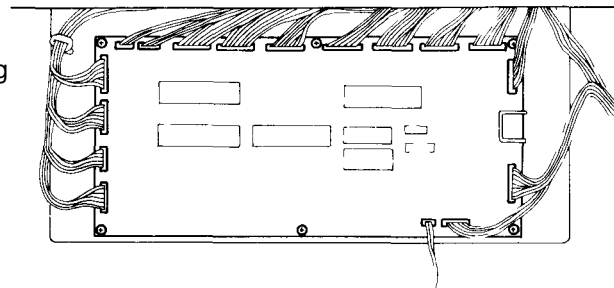

(Fig.8)

**8. Pedal sensor unit (figure 9)**

Detach I/O board connectors, and remove screws ⑧ x 2

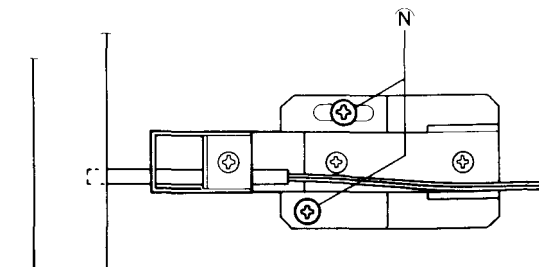

(Fig.9)

**9. Power supply unit (figure 10)**

Remove connectors connecting the power supply unit to the

- Key drive unit
- I/O board
- Power transformer
- Noise filter

Loosen and remove the unit attaching screws

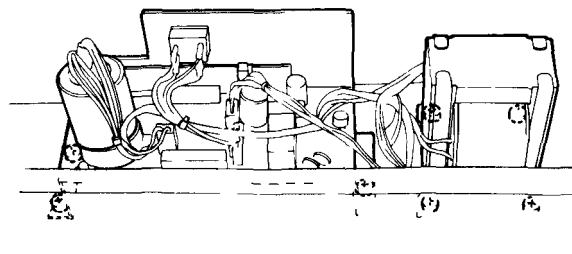

(Fig.10)

**10. Replacing the ROM**

The MX80 has one ROM on the control board and one ROM on the I/O board

After replacing the ROM, run the various test programs to check functioning

(Refer to the explanation of the test program )

< ROM installation locations > (figure 11)

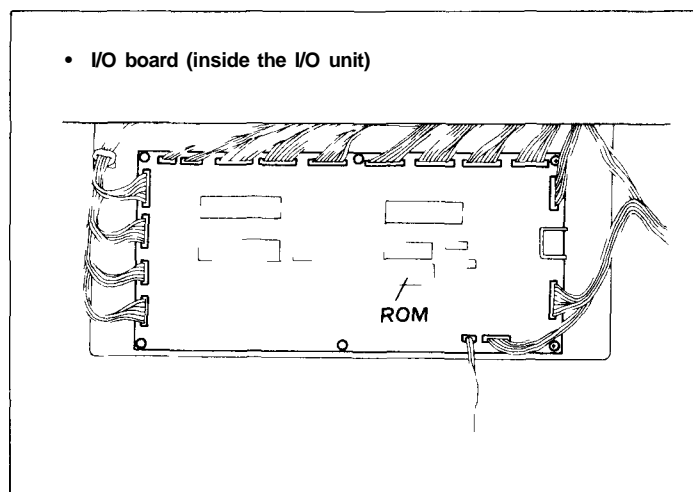
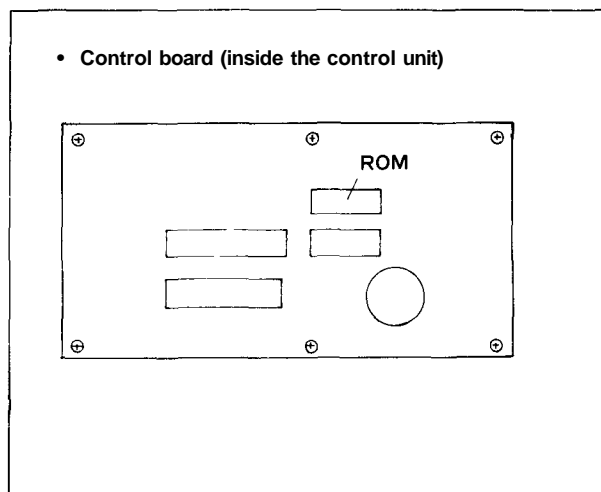

(Fig.11)

## ■ Trouble Shooting by LED on I/O Board

LED 1~3 on the I/O board will light to indicate the following three types of malfunction. (When normal, all LEDs will be off.) A protection circuit will operate, turning off the 100V power supply that drives the solenoids.

### LED locations and types of malfunction

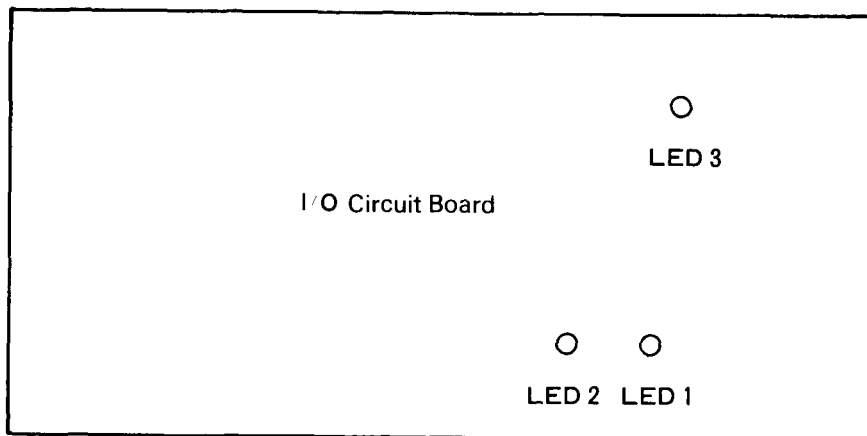

- LED 1 ... This will light when the temperature in the key drive unit becomes abnormally high, and the thermostat operates.
- LED 2 ... This will light to indicate a malfunction in the drive system. (A malfunctioning drive transistor or diode in the key drive unit. A malfunctioning drive transistor on the pedal drive relay board, or a malfunctioning diode in the pedal solenoid.)
- LED 3 ... This will light to indicate a malfunction of the CPU on the I/O board.

■ Circuit Boards

● Control Circuit Board

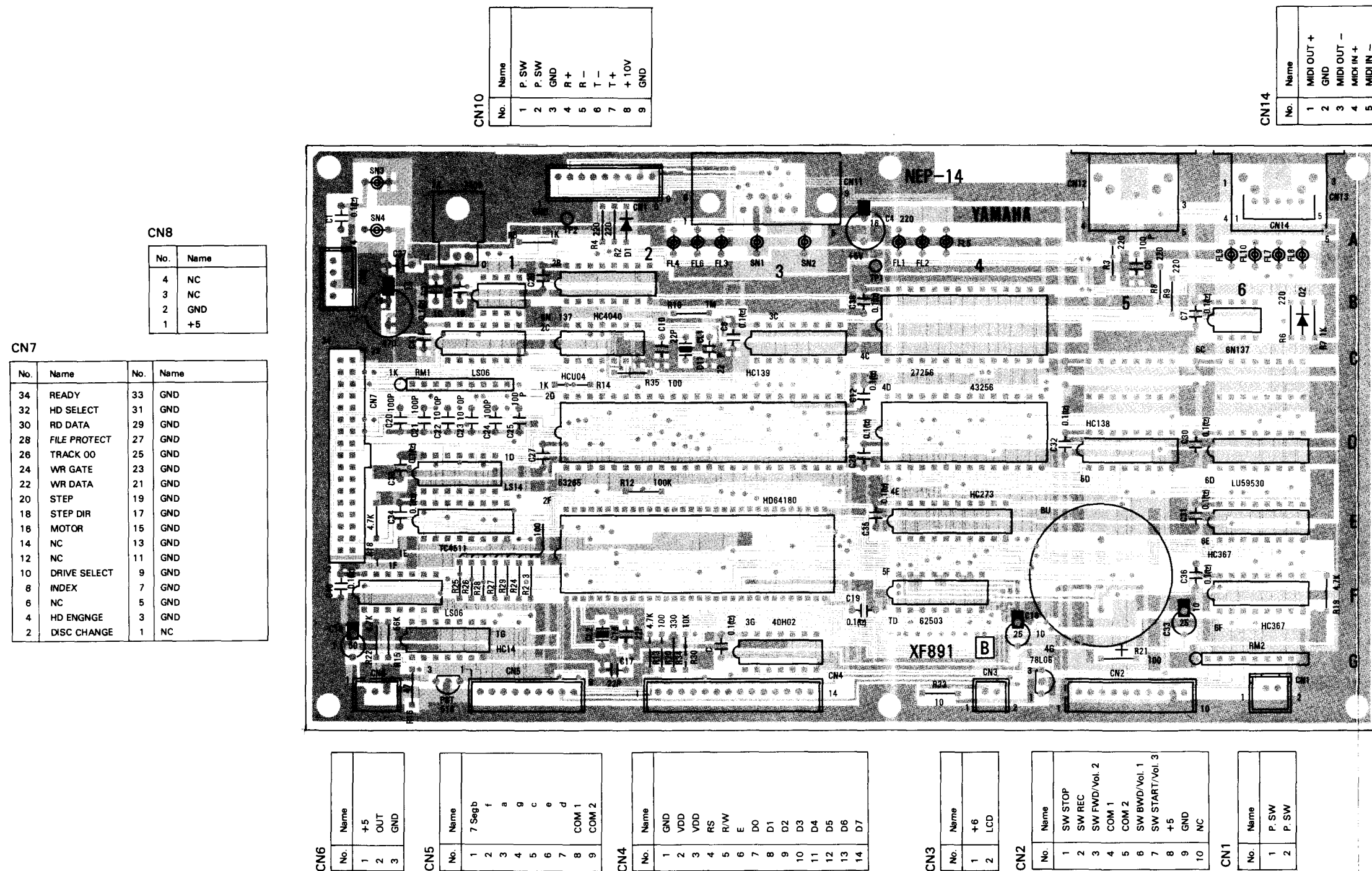

**CN7**

No.	Name	No.	Name
34	READY	33	GND
32	HD SELECT	31	GND
30	RD DATA	29	GND
28	FILE PROTECT	27	GND
26	TRACK 00	25	GND
24	WR GATE	23	GND
22	WR DATA	21	GND
20	STEP	19	GND
18	STEP DIR	17	GND
16	MOTOR	15	GND
14	NC	13	GND
12	NC	11	GND
10	DRIVE SELECT	9	GND
8	INDEX	7	GND
6	NC	5	GND
4	HD ENGNCE	3	GND
2	DISC CHANGE	1	NC

**CN8**

No.	Name
4	NC
3	NC
2	GND
1	+5

**CN10**

No.	Name
1	P. SW
2	P. SW
3	GND
4	R +
5	R -
6	T -
7	T +
8	+10V
9	GND

**CN14**

No.	Name
1	MIDI OUT +
2	GND
3	MIDI OUT -
4	MIDI IN +
5	MIDI IN -

**CN6**

No.	Name
1	+5
2	OUT
3	GND

**CN5**

No.	Name
1	7 Seg b
2	f
3	a
4	g
5	c
6	e
7	d
8	COM 1
9	COM 2

**CN4**

No.	Name
1	GND
2	VDD
3	VDD
4	RS
5	R/W
6	E
7	DO
8	D1
9	D2
10	D3
11	D4
12	D5
13	D6
14	D7

**CN3**

No.	Name
1	+6
2	LCD

**CN2**

No.	Name
1	SW STOP
2	SW REC
3	SW FWD/Vol. 2
4	COM 1
5	COM 2
6	SW BWD/Vol. 1
7	SW START/Vol. 3
8	+5
9	GND
10	NC

**CN1**

No.	Name
1	P. SW
2	P. SW

MX80

•LED Circuit Board(7segment)

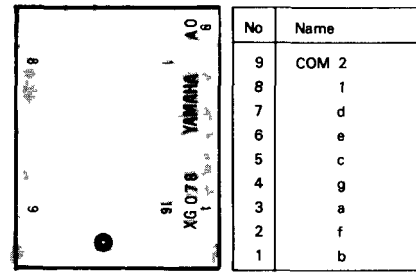

•Detect Circuit Board (remote control sensor)

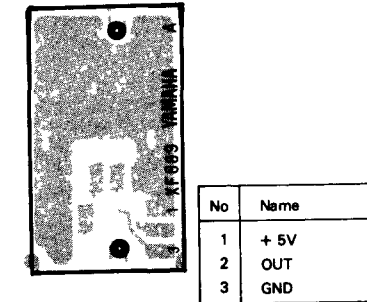

•SW Circuit Board(remote control sensor)

No	Name
9	NC
8	NC
7	START/Vol 3
6	BWD/Vol 1
5	COM 2
4	COM 1
3	FWD/Vol 2
2	REC
1	STOP

No	Name
1	P SW
2	P SW

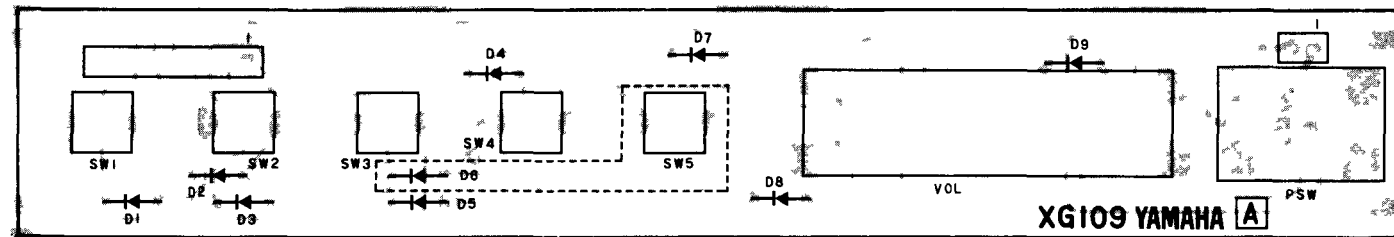

•Connector Circuit Board

No	Name
1	R +
2	+ 10V
3	GND
4	P SW
5	T -
6	R -
7	GND
8	P SW
9	T +

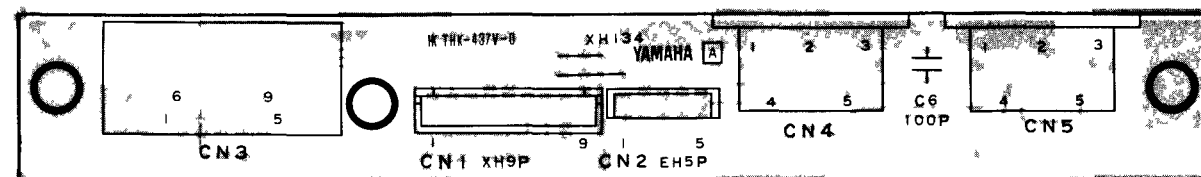

MX80

•I/O Circuit Board

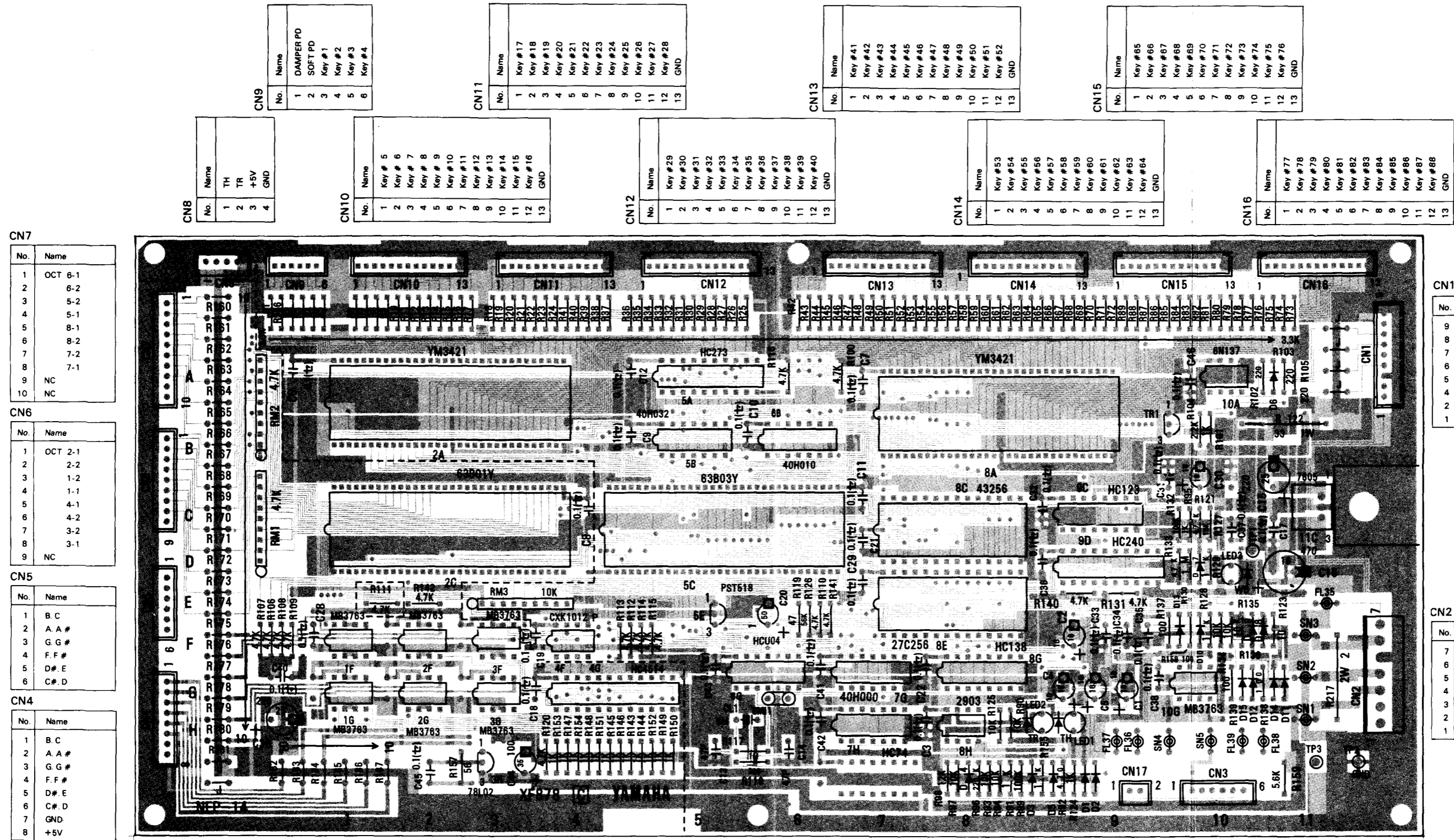

CN7

No.	Name
1	OCT 6-1
2	6-2
3	5-2
4	5-1
5	8-1
6	8-2
7	7-2
8	7-1
9	NC
10	NC

CN6

No.	Name
1	OCT 2-1
2	2-2
3	1-2
4	1-1
5	4-1
6	4-2
7	3-2
8	3-1
9	NC

CN5

No.	Name
1	B.C
2	A.A #
3	G.G #
4	F.F #
5	D# E
6	C# D

CN4

No.	Name
1	B.C
2	A.A #
3	G.G #
4	F.F #
5	D# E
6	C# D
7	GND
8	+5V

CN8

No.	Name
1	TH
2	TR
3	+5V
4	GND

CN9

No.	Name
1	DAMPER PD
2	SOFT PD
3	Key #1
4	Key #2
5	Key #3
6	Key #4

CN10

No.	Name
1	Key #5
2	Key #6
3	Key #7
4	Key #8
5	Key #9
6	Key #10
7	Key #11
8	Key #12
9	Key #13
10	Key #14
11	Key #15
12	Key #16
13	GND

CN11

No.	Name
1	Key #17
2	Key #18
3	Key #19
4	Key #20
5	Key #21
6	Key #22
7	Key #23
8	Key #24
9	Key #25
10	Key #26
11	Key #27
12	Key #28
13	GND

CN12

No.	Name
1	Key #29
2	Key #30
3	Key #31
4	Key #32
5	Key #33
6	Key #34
7	Key #35
8	Key #36
9	Key #37
10	Key #38
11	Key #39
12	Key #40
13	GND

CN13

No.	Name
1	Key #41
2	Key #42
3	Key #43
4	Key #44
5	Key #45
6	Key #46
7	Key #47
8	Key #48
9	Key #49
10	Key #50
11	Key #51
12	Key #52
13	GND

CN14

No.	Name
1	Key #53
2	Key #54
3	Key #55
4	Key #56
5	Key #57
6	Key #58
7	Key #59
8	Key #60
9	Key #61
10	Key #62
11	Key #63
12	Key #64
13	GND

CN15

No.	Name
1	Key #65
2	Key #66
3	Key #67
4	Key #68
5	Key #69
6	Key #70
7	Key #71
8	Key #72
9	Key #73
10	Key #74
11	Key #75
12	Key #76
13	GND

CN16

No.	Name
1	Key #77
2	Key #78
3	Key #79
4	Key #80
5	Key #81
6	Key #82
7	Key #83
8	Key #84
9	Key #85
10	Key #86
11	Key #87
12	Key #88
13	GND

CN1

No.	Name
9	GND
8	+10V
7	R+
6	R-
5	T+
4	GND
2	SYSTEM ON
1	SYSTEM ON

CN2

No.	Name
7	100 V OFF
6	+10V
5	GND
4	+18V
3	GND
2	SYSTEM ON
1	SYSTEM ON

CN17

No.	Name
1	PEDAL SENSOR
2	PD COMON

CN3

No.	Name
1	MOTOR FWD
2	MOTOR BWD
3	MUTE LO END
4	MUTE HI END
5	PEDAL SENSOR
6	PD COMON

MX80

•Drive B Circuit Board

No	Name
6	DC 100V
5	DC 100V
4	NC
3	TR
2	GND
1	GND

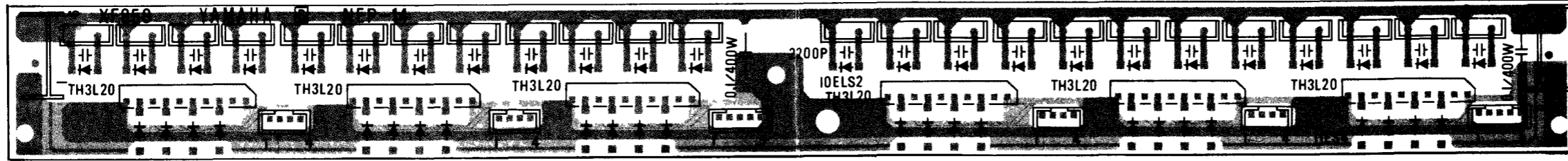

No	Name
6	DC 100V
5	DC 100V
4	NC
3	TR
2	GND
1	GND

No	Name
1	Key# 17, 41, 65
2	Key# 18, 42, 66
3	Key# 19, 43, 67
4	Key# 20, 44, 68

No	Name
1	Key# 21, 45, 69
2	Key# 22, 46, 70
3	Key# 23, 47, 71
4	Key# 24, 48, 72

No	Name
1	Key# 25, 49, 73
2	Key# 26, 50, 74
3	Key# 27, 51, 75
4	Key# 28, 52, 76
5	GND

No	Name
1	Key# 29, 53, 77
2	Key# 30, 54, 78
3	Key# 31, 55, 79
4	Key# 32, 56, 80

No	Name
1	Key# 33, 57, 81
2	Key# 34, 58, 82
3	Key# 35, 59, 83
4	Key# 36, 60, 84
5	GND

No	Name
1	Key# 37, 61, 85
2	Key# 38, 62, 86
3	Key# 39, 63, 87
4	Key# 40, 64, 88
5	GND

•Drive C Circuit Board

No	Name
1	TH1
2	GND

No	Name
6	TR
5	DAMPER PD
4	SOFT PD
3	GND
2	NC
1	DC100V

No	Name
1	TH2
2	TH2

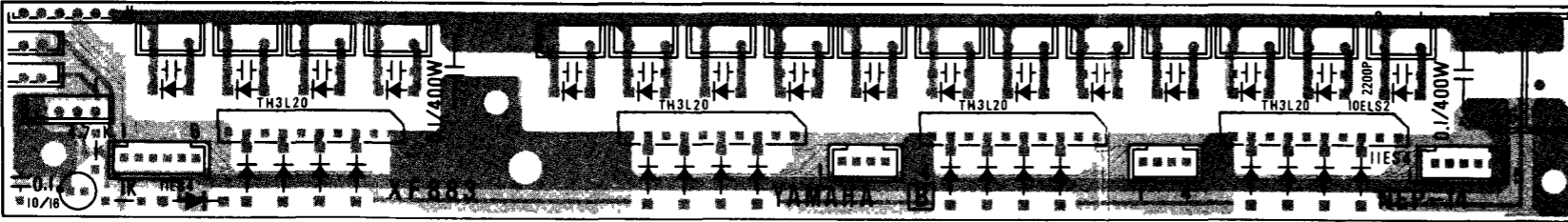

No	Name
6	DC 100V
5	DC 100V
4	NC
3	TH
2	GND
1	GND

No	Name
4	GND
3	+5V
2	TR
1	TH

No	Name
1	DAMPER PD
2	SOFT PD
3	Key #1
4	Key #2
5	Key #3
6	Key #4

No	Name
1	Key# 5
2	Key# 6
3	Key# 7
4	Key# 8

No	Name
1	Key# 9
2	Key# 10
3	Key# 11
4	Key# 12

No	Name
1	Key# 13
2	Key# 14
3	Key# 15
4	Key# 16
5	GND

•Sensor A Circuit Board

CN3, 6, 9

No	Name
8	VDD
7	GND
6	C#, D
5	D#, E
4	F, F#
3	G, G#
2	A, A#
1	B, C

CN2, 5, 8

No	Name
4	OCT 7, 5, 3-1
3	OCT 7, 5, 3-2
2	OCT 8, 6, 4-2
1	OCT 8, 6, 4-1

CN1, 4, 7

No	Name
8	VDD
7	GND
6	C#, D
5	D#, E
4	F, F#
3	G, G#
2	A, A#
1	B, C#

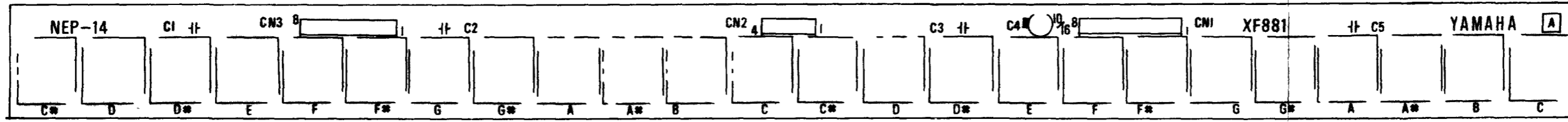

•Sensor B Circuit Board

CN12

No	Name
6	C#, D
5	D#, E
4	F, F#
3	G, G#
2	A, A#
1	B, C

CN11

No	Name
4	OCT 1-1
3	OCT 1-2
2	OCT 2-2
1	OCT 2-1

CN10

No	Name
8	VDD
7	GND
6	C#, D
5	D#, E
4	F, F#
3	G, G#
2	A, A#
1	B, C

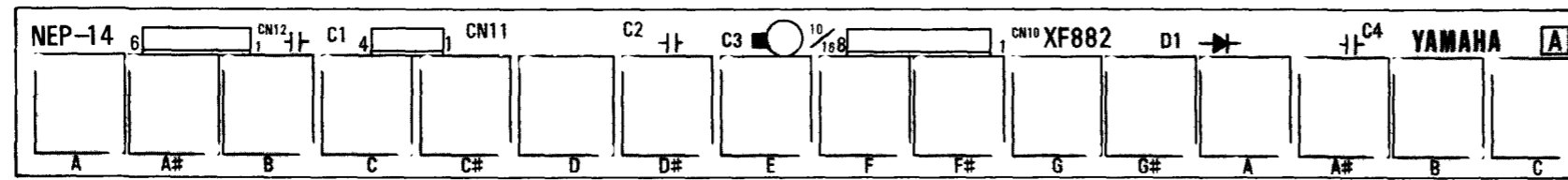

MX80

• Relay Circuit Board

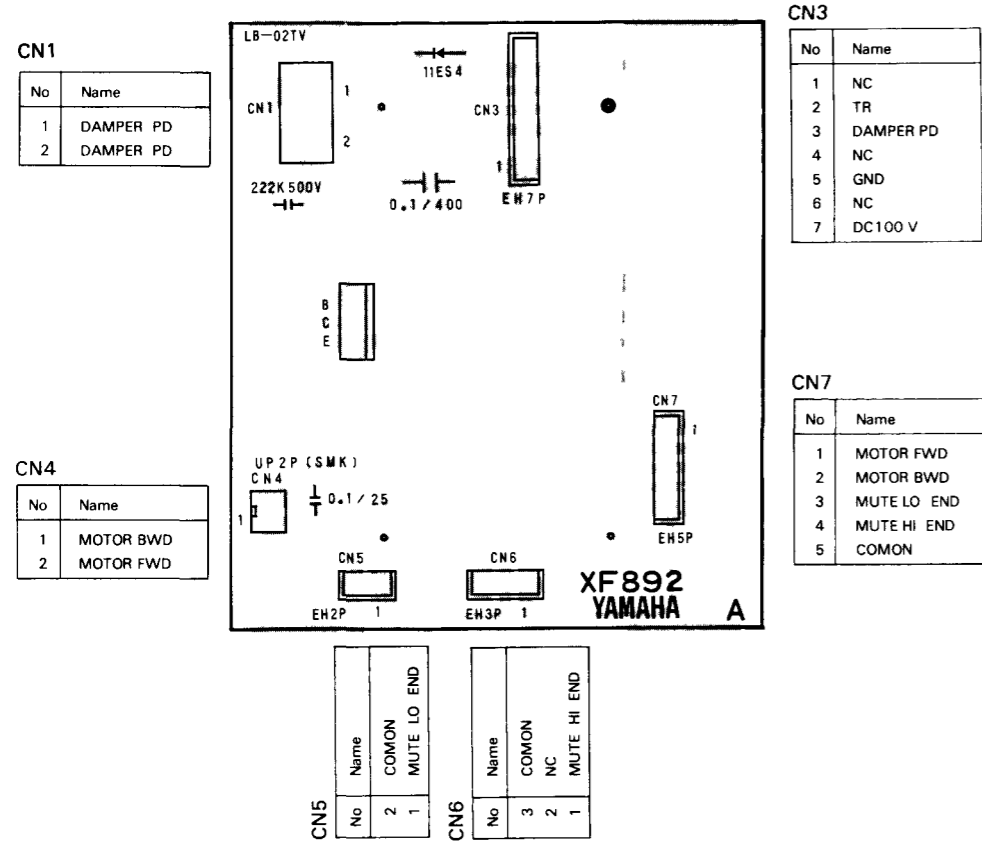

• Power Supply Circuit Board

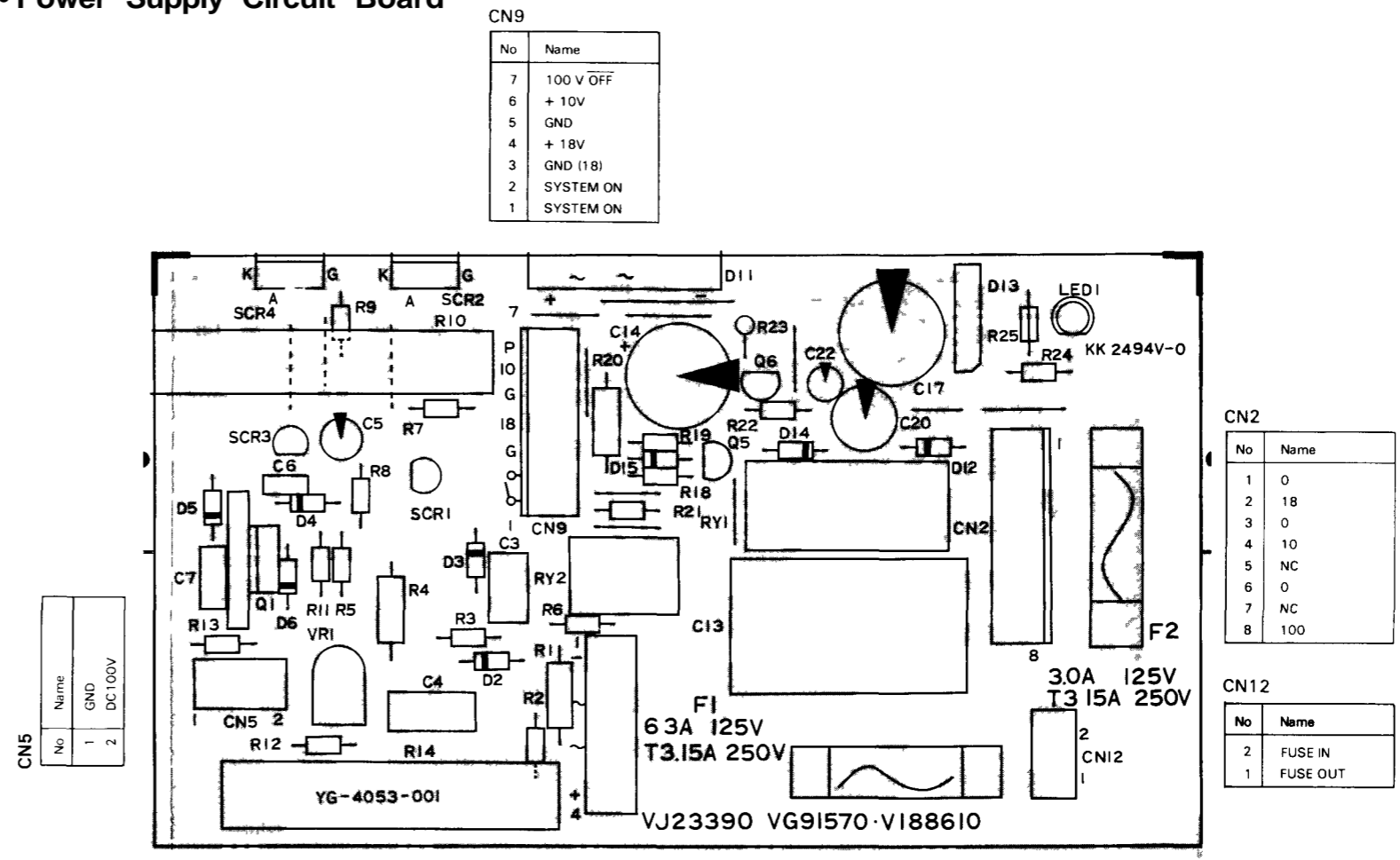

# disklavier

## MX80

### PARTS LIST

**Market**

U	US	E	European
C	Canadian	A	Australian
B	British		

Electrical Parts	1
1 Control Unit	7
2 Key Drive Unit	9
3 Pedal Drive Unit, Mute Sensor Unit	11
4 I/O Unit, Power Supply Unit	13
5 Key Sensor Unit	15
6 Pedal Sensor Unit	16

## Electrical Parts

Ref. No.	Part No.	Description		部品名	Remarks
		<b>Control Unit</b>	<b>コントロールユニット</b>		
*	VI922900	Circuit Board, Control		コントロールシート	
*	XC381A00	IC	HD64180RI	IC	CPU
*	XG708A00	IC	62256	IC	SRAM
*	XF895A00	IC	HD63265P	IC	FDC
*	XH260C00	IC	27C256	IC	EPROM
	iG096300	IC	40H002	IC	Quad 2In NOR
	iG067210	IC	TC4511BP	IC	BCD to 7 Latch
	iR027350	IC	74HC273	IC	Octal D F-F
	iR036750	IC	74HC367	IC	Hex 3Stage Buf.
	iR013850	IC	74HC138	IC	3-8 Decoder
	iR404050	IC	74HC4040	IC	12 Binary Count
	iR001450	IC	74HC14	IC	Hex Schmitt Inv
	iR013950	IC	74HC139	IC	Dual 2-4 Decode
	iG142200	IC	74HC004	IC	Hex Inverter
	iG059100	IC	74LS06	IC	Hex Inv./Buffer
	iG049600	IC	74LS14	IC	Schmitt Trigger
	XC722001	IC	PST518	IC	Reset IC
	iG147600	IC	7805	IC	+5V Regulator
	iG111000	IC	TD62503	IC	TR Array
	XE924001	IC	78L06	IC	Regulator
*	XF937A00	IC	LU59530	IC	Remocon Decoder
	VD473200	Photo Conductor	6N137	IC	
	VA106500	Diode	1SS176	ダイオード	
	VB650600	Ceramic Resonator	CSA16.00HX	セラミック振動子	16MHz
*	VG931300	Ceramic Resonator	CSA10.00MT040	セラミック振動子	10MHz
	VD473700	Coil	60μH	SBTコイル	
	LB607330	IC Socket	28P	ICソケット	
	HZ004730	Resistor Array	10KIX8	抵抗アレイ	
	VB350600	Resistor Array	1KIX8	抵抗アレイ	
	FZ005030	Semi-conductive Cera. Cap.	0.1μF/25V	半導体セラコン	
	VJ107300	Buzzer	PKB9-2A0	圧電ブザー	
	LB918020	Connector XH Type, Top	2P	XHコネクタ	P.SW
	LB918040	Connector XH Type, Top	4P	XHコネクタ	FDD
	VD650400	Connector EH Type, Top	2P	EHコネクタ	LCD
	VC014700	Connector EH Type, Top	3P	EHコネクタ	RMCN
*	VC014900	Connector EH Type, Top	5P	EHコネクタ	MIDI
*	VC015300	Connector EH Type, Top	9P	EHコネクタ	LED
*	VD650700	Connector EH Type, Top	10P	EHコネクタ	SW
*	VD853800	Connector EH Type, Top	14P	EHコネクタ	LCD
	LB604400	Connector	34P	34Pソケット	FDD
*	Vi898900	Circuit Board, Connector		FCC補助シート	
	VH277700	D-SUB Connector	9S	D-SUBコネクタ	
	LB500520	DIN Socket	5P	DINコネクタ	
	LB918090	Connector XH Type, Top	9P	XHコネクタ	
	VC014900	Connector EH Type, Top	5P	EHコネクタ	

\* New Parts

Ref. No.	Part No.	Description		部 品 名	Remarks
* * * *	VH626100 KA906550 VG921800 VG929000 VA106500	Circuit Board, SW Tact Switch Digital Slide Switch Push Switch Diode	SSGC11 SPEC12 LSS176	SW シート タクトスイッチ デジタルスライドSW プッシュSW ダイオード	
* *	VG916500 VG921700 FZ005030	<b>Circuit Board, Detect</b> Sensor, Remo-Con Ceramic Capacitor	A1QH3111HO 01 $\mu$ F/25V	受光シート リモコン受光器 セラコン	
* * *	VG916400 VG922200  VH633000 VF881200	Circuit Board, LED 7Seg. LED  LCD Unit LCD	   14x2	LED シート 7Seg. LED  LCD ユニット LCD	
* *	Vi963800 VG922300	FDD Cable, FDD	3.5'	FDD 束線 FDD	
* *	VH903800 VJ569800	Key Drive Unit Key Drive Unit		キードライブユニット キードライブユニット	U, C B, E, A
* * * *	VG915200 VG915300 VH097200 VB481900 VB293700	Circuit Board, Drive (B) Circuit Board, Drive (C) First Recovery Diode Diode TR Array	24Key 16Key 10ELS2 11ES4 TH3L20	ドライブ(B)シート ドライブ(C)シート ファストリカバリダイオード ダイオード トランジスタアレイ	
* *	FC045100 VC014700 VD650500 VC016400 VD650400	Mylar Film Capacitor Connector, EH Type Top Connector, EH Type Top Connector, EH Type Side Connector, EH Type Top	0.1 $\mu$ F/400V 3P 4P 6P 2P	マイラーコンデンサ EH コネクタ EH コネクタ EH コネクタ EH コネクタ	
	VC015000 VB390000 VB390100 VB390200	Connector, EH Type Top Connector, PH Type Top Connector, PH Type Top Connector, PH Type Top	6P 4P 5P 6P	EH コネクタ PH コネクタ PH コネクタ PH コネクタ	
* * * * *	VG927100 VG927200 VG967300 VG967400 VG927300	Coil Ass'y (A) Coil Ass'y (B) Coil Ass'y (AL) Coil Ass'y (BL) Thermostat	l=60 BL l=35 WH l=75 BL l=50 WH	PPコイルキット(A) PPコイルキット(B) PPコイルキット(AL) PPコイルキット(BL) サーモスタット	ODD Key EVEN Key Key # 1,17,39 Key # 40
		Pedal Drive Unit		ペダルドライブユニット	
* *	VG923700 VH648700	Pedal Solenoid Motor, Mute		ペダルソレノイド ギヤードモーター	

\* New Parts

Ref. No.	Part No.	Description	部 品 名	Remarks
		I/O Unit	I/O ユニット	
* * * * *	Vi905500 XF908A00 XD245001 XF863A00 XF879A00	Circuit Board, I/O IC IC IC IC	HD63B01Y HD63B03Y MPD43C256AC CXK1012P	I/O シート IC IC IC IC CPU CPU SRAM →XG708A00 EEPROM
* * * * *	XG171E00 iT342100 XF880A00 iG031000 iG142200	IC (XG003A00) IC IC IC IC	27C256-20FA YM3421 ME3763 NJM2903 74HCU04	IC IC IC IC IC EPROM PWM  Hex Inverter
	iG080700 iG100200 iG052800 iR024050 iR013850	IC IC IC IC IC	40H000 40H10 40H32 74HC240 74HC138	IC IC IC IC IC Quad NAND NAND Gate Quad 2in OR Bus Buffer 3-8 Line Decode
* * * * *	iR451400 iR027350 iR012300 iR007400 XC722001	IC IC IC IC IC	TC74HC4514 74HC273 74HC123 74HC074 PST518	IC IC IC IC IC Octal D F-F Dual Mono Multi Dual D F-F Reset IC
* * * * *	iG147600 XG149A00 VD473200 iC181520 VA106500	IC IC Photo Conductor Transistor Diode	7805 78L02 6NL37 2SC1815 1SS176	IC IC フォトカプラー トランジスタ ダイオード +5V Regulator +2.6V Regulator
* * * * *	iF003940 VE364800 GE901870 VD473700 LB607330	LED Ceramic Resonator Coil Coil IC Socket	GL-5PR2 CSA8.00MT040 10μH 60μH 28P	LED セラミック振動子 SN コイル SBT コイル ICソケット RED 8MHz
	HL314330 VB594000 HZ004730 FZ005030 FZ004100	Metal Oxide Film Resistor Resistor Array Resistor Array Semi-Conductive Cera. Cap. Semi-Conductive Cera. Cap.	33Ω/1P 4.7KΩX8 10KΩX8 0.1μF/25V 0.1μF/16V	酸金抵抗 抵抗アレイ 抵抗アレイ 半導体セラコン 半導体セラコン
	LB918090 LB932070 VD650500 VC015000 VC015200	Connector, XH Type Top Connector, VH Type Connector, EH Type Top Connector, EH Type Top Connector, EH Type Top	9P 7P 4P 6P 8P	XHコネクタ VHコネクタ EHコネクタ EHコネクタ EHコネクタ
* * * *	VC015300 VD650700 VB390200 VF283100	Connector, EH Type Top Connector, EH Type Top Connector, PH Type Top Connector, PH Type Top	9P 10P 6P 1P	EHコネクタ EHコネクタ PHコネクタ PHコネクタ

\* New Parts

Ref. No.	Part No.	Description	部品名	Remarks	
* *	Vi886100 VJ233900	Power Supply Unit Power Supply Unit	電源ユニット 電源ユニット	U, C B, E, A	
	iH000390 iX603810 iX554290 iF000460	Diode Diode Diode Diode	KBPC2504 10E-4 1S1585 1S1555	ダイオードブリッジ ダイオード ダイオード ダイオード	D1 D2, D12 D3 D4, 6, 14, 15
* *	iF001470 iX554450 iX553200 iC223840 1C098200	Zener Diode Diode Diode Transistor Transistor	RD6.2EB2 D3SBA10 S1VB10 2SC2238B 2SC982	ツェナーダイオード ダイオード ダイオード トランジスタ トランジスタ	D5 D11 D13 Q1 Q5, Q6
* *	iX554310 iH001050 iH000420 HX500030 HX500040	Diode Triac SCR Cement Molded Resistor Cement Molded Resistor	BS08A AC16DGM-L CR02AM-4 12Ω/10W 4.7KΩ/10W	ダイアック サイリスタ サイリスタ セメント抵抗 セメント抵抗	SCR1 SCR2, 4 SCR3 R10 R14
	HL327220 HL327100 HL314560 FX551630 FX550990	Metal Oxide Film Resistor Metal Oxide Film Resistor Metal Oxide Film Resistor Film Capacitor Film Capacitor	22KΩ/2W 10KΩ/2W 56Ω/1W 0.15μF/250V 0.22μF/250V	酸化抵抗 酸化抵抗 酸化抵抗 フィルムコン フィルムコン	R1 R4 R20 C3 C4
* *	UJ118470 FX551640 FX800230 FX551670 FX551660	Electrolytic Capacitor Film Capacitor Ceramic Capacitor Electrolytic Capacitor Electrolytic Capacitor	470μF/6.3V 0.01μF/50V 100PF/1KV 15000μ/200V 6800μF/16V	ケミコン フィルムコン セラコン ケミコン ケミコン	C5 C6 C7 C8 C14
* *	UJ159220 KX550710 KX550720 HX551760 KX550730	Electrolytic Capacitor Relay Relay Semi Variable Resistor Fuse	2200μF/35V G2R-2217P-V G6E-184P-US 10KΩ RVF08P 6.3A 125V UL	ケミコン リレー リレー 半固定VR ヒューズ	C17 RY1 RY2 VR1 F1 U, C
* *	KB002000 KB002380 VH785100 iX554460	Fuse Fuse Switch LED	3.0A 125V 3.15AT 250V SDDT-DPSP-A-1 GL5TR43	ヒューズ ヒューズ スイッチ LED	F2 U, C F1, 2 B, E, A SW1 U, C LED1
* * * * *	XG592A00 XH614A00 XH615A00 Vi880800 VJ161500	Power Transformer Power Transformer Power Transformer AC Cord Unit AC Cord Unit		電源トランス 電源トランス 電源トランス 電源コードユニット 電源コードユニット	U, C E B, A U, C E
* *	VJ222500 VJ402800 MG000820 VF757900 VF758000	AC Cord Unit AC Cord Unit AC Cord AC Cord AC Cord		電源コードユニット 電源コードユニット 電源コード 電源コード 電源コード	A B U, C E A
* *	VH895700 VH412800 Vi906700 VE555800 VH413000	AC Cord Switch D-SUB Cable Noise Filter Terminal	1802 PBF-1206-22	電源コード シーソースイッチ D-SUB ケーブル ノイズフィルター 2P連結端子台	B B, E, A B, E, A
	Fi383330	SP Capacitor	3300P	コンデンサ	B, E, A

\* New Parts

Ref. No.	Part No.	Description		部 品 名	Remarks
*	VJ233800	Key Sensor Unit		キーセンサーユニット	
*	VG915900	Circuit Board, Sensor (A)	24Key	センサーシート(A)	
*	VG916000	Circuit Board, Sensor (B)	16Key	センサーシート(B)	
*	VG918600	Photo Diode	GP3A70	フォトインタラプタ	
*	Ui366100	Electrolytic Capacitor	1 $\mu$ F/50V	超小型ケミコン	
*	FZ006330	Ceramic Capacitor	0.1 $\mu$ F/16V	セラコン	
	VB482000	Diode	11ES4	ダイオード	
	VC015200	Connector EH Type, Top	8P	EHコネクタ	
	VC015000	Connector EH Type, Top	6P	EHコネクタ	
	VD650500	Connector EH Type, Top	4P	EHコネクタ	
*	VH217100	Pedal Sensor Unit		ペダルセンサーユニット	
*	NB037050	Tablet Switch	M	タブレットスイッチ	
*	VC013000	Connector Housing, EH Type	2P	EHハウジング	
*	VC267600	Connector Pin, EH Type		EHコンタクト	
		Mute Sensor Unit		ミュートセンサーユニット	
*	VG916700	Circuit Board, Connector		ソレノイド中継シート	
*	FC045100	Mylar Film Capacitor	0.1 $\mu$ F/400V	マイラーコン	
*	VC694800	Ceramic Capacitor	0.1 $\mu$ F/25V	セラコン	
*	VB481900	Diode	11ES4	ダイオード	
*	iD102300	Transistor	2SD1023	トランジスタ	
	LB201910	Cap, 2P	LB-02TV	2Pキャップ	
	VD650400	Connector EH Type, Top	2P	EHコネクタ	
	VC014700	Connector EH Type, Top	3P	EHコネクタ	
	VC014900	Connector EH Type, Top	5P	EHコネクタ	
*	VC015100	Connector EH Type, Top	7P	EHコネクタ	
	VC488000	Connector UP Type, Top	2P	UPコネクタ	

\* New Parts

Ref. No.	Part No.	Description		部 品 名	Remarks
		Cables & Connectors	ケーブル・コネクタ類		
*	MG000820 VF757900 VF758000 VH895700 Vi906700	AC Cord AC Cord AC Cord AC Cord D-SUB Cable		電源コード 電源コード 電源コード 電源コード D-SUBケーブル	U, C E A B
*	VC013000 VC013100 VC013200 VC013300 VC013400	Connector Housing, EH Type Connector Housing, EH Type Connector Housing, EH Type Connector Housing, EH Type Connector Housing, EH Type	2P 3P 4P 5P 6P	EHハウジング EHハウジング EHハウジング EHハウジング EHハウジング	
*	VC013500 VC013600 VC013700 VC013800 VC014300	Connector Housing, EH Type Connector Housing, EH Type Connector Housing, EH Type Connector Housing, EH Type Connector Housing, EH Type	7P 8P 9P 10P 14P	EHハウジング EHハウジング EHハウジング EHハウジング EHハウジング	
*	VC267600 VB304500 VB304600 VB304700 VH346900	Contact Pin, EH Type Connector Housing, PH Type Connector Housing, PH Type Connector Housing, PH Type Connector Housing, PH Type	4P 5P 6P 13P	EHコンタクト PHハウジング PHハウジング PHハウジング PHハウジング	
*	VB936800 LB009020 LB009040 LB009090 LB101130	Contact Pin, PH Type Connector Housing, XH Type Connector Housing, XH Type Connector Housing, XH Type Contact Pin, XH Type	2P 4P 9P	PHコンタクト XHハウジング XHハウジング XHハウジング XHコンタクト	
*	LB015070 LB101710 LB201430 LB603470 LB100670	Connector Housing, VH Type Contact Pin, VH Type Connector Housing, LP Type Connector Housing, LP Type Contact Pin, LP Type	7P 2P 6P	VHハウジング VHコンタクト LPハウジング LPハウジング LPコンタクト	
*	VB751000 VF418000	Connector Housing, P/N Type Contact Pin, P/N Type	4P	P/Nハウジング P/Nコンタクト	

MX80

\* New Parts

# 1. Control Unit

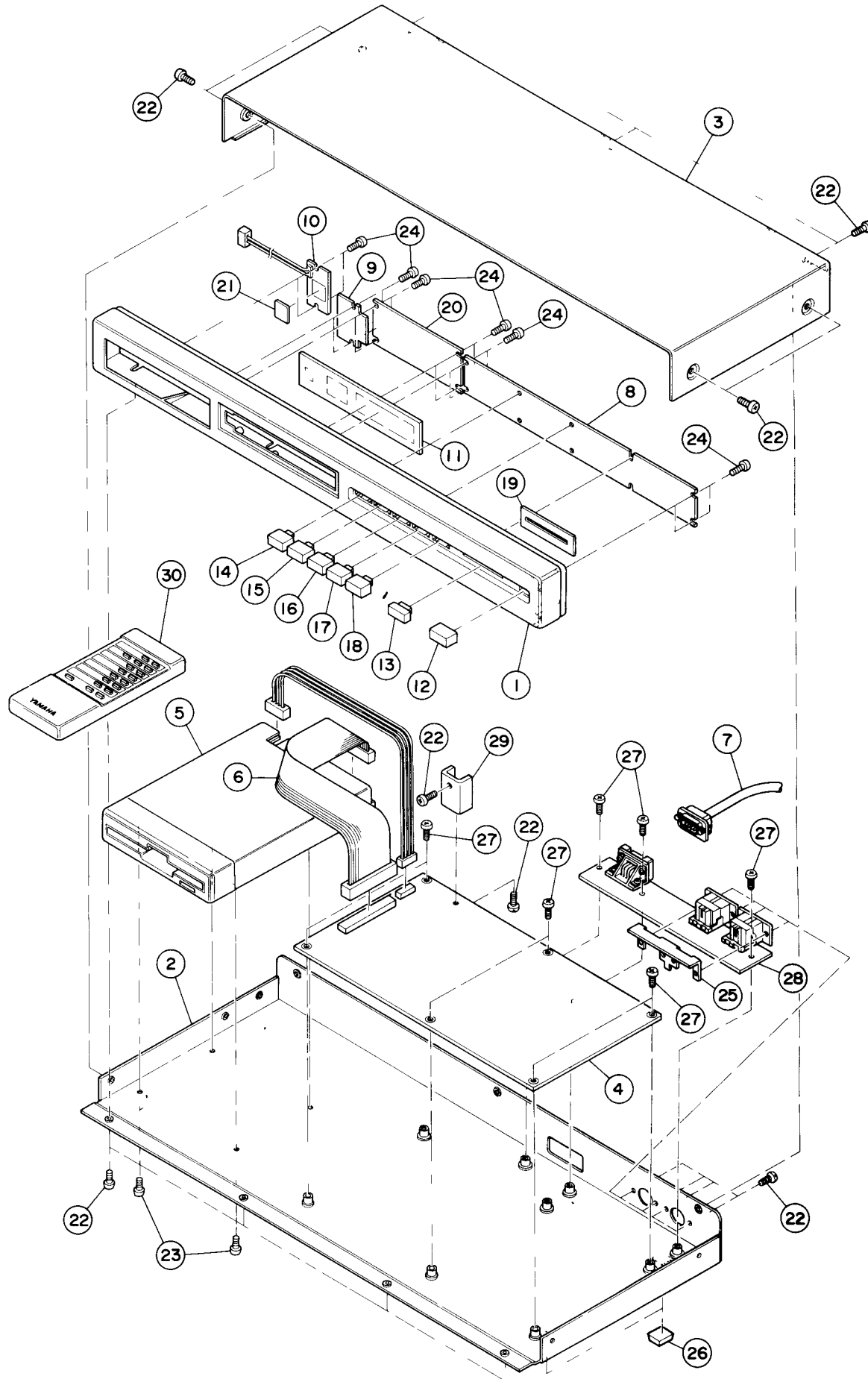

MX80

Ref. No.	Part No.	Description		部 品 名	Remarks
* 1	Vi922300	Control Panel		コントロールパネル	
* 2	Vi798800	Bottom Cover		コントロールボトム	
* 3	Vi798900	Top Cover		コントロールカバー	
* 4	Vi922900	Circuit Board, Control		コントロールシート	
* 5	Vi963800	FDD	3.5'	FDD	
* 6	VG922300	Cable, FDD		束線 FDD	
* 7	Vi906700	Cable, CT-I/O		D-SUB ケーブル M1	
* 8	VH626100	Circuit Board, SW		SW シート	
* 9	VG916400	Circuit Board, LED		LED シート	
* 10	VG916500	Circuit Board, Detect		受光シート	
* 11	Vi145500	LCD Panel		LCD マスク	
* 12	VH569900	Key Top	POWER	キートップ	
* 13	VH570100	Key Top	VOLUME	キートップ	
* 14	VH570200	Key Top	PLAY	キートップ	
* 15	VH570300	Key Top	BWD	キートップ	
* 16	VH570400	Key Top	FWD	キートップ	
* 17	VH570500	Key Top	STOP	キートップ	
* 18	VH570600	Key Top	REC	キートップ	
* 19	CA500450	Dust-Proof Cover		防塵シート	
* 20	VH633000	LCD Unit		LCD ユニット	
* 21	VG967200	Filter, Remo-Con		リモコンフィルター	
22	ED330066	Bind Head Screw	3x6 BL	バインド小ネジ	
23	ED330086	Bind Head Screw	3x8 BL	バインド小ネジ	
24	Ei320056	Bind Tapping Screw	2x5 BL	バインドタッピングネジ	
25	AA831250	Holder, DIN Socket		DINソケットホルダー	
26	CB834350	Leg	BL	ゴム脚	
27	ED030056	Bind Head Screw	3x5 YE	バインド小ネジ	
* 28	Vi898900	Circuit Board, Connector		FCC補助シート	
29	VH081600	Heat Sink		トランジスタ放熱板	
30	VE514700	Remote Control Unit		リモコンユニット	

\* New Parts

## 2. Key Drive Unit

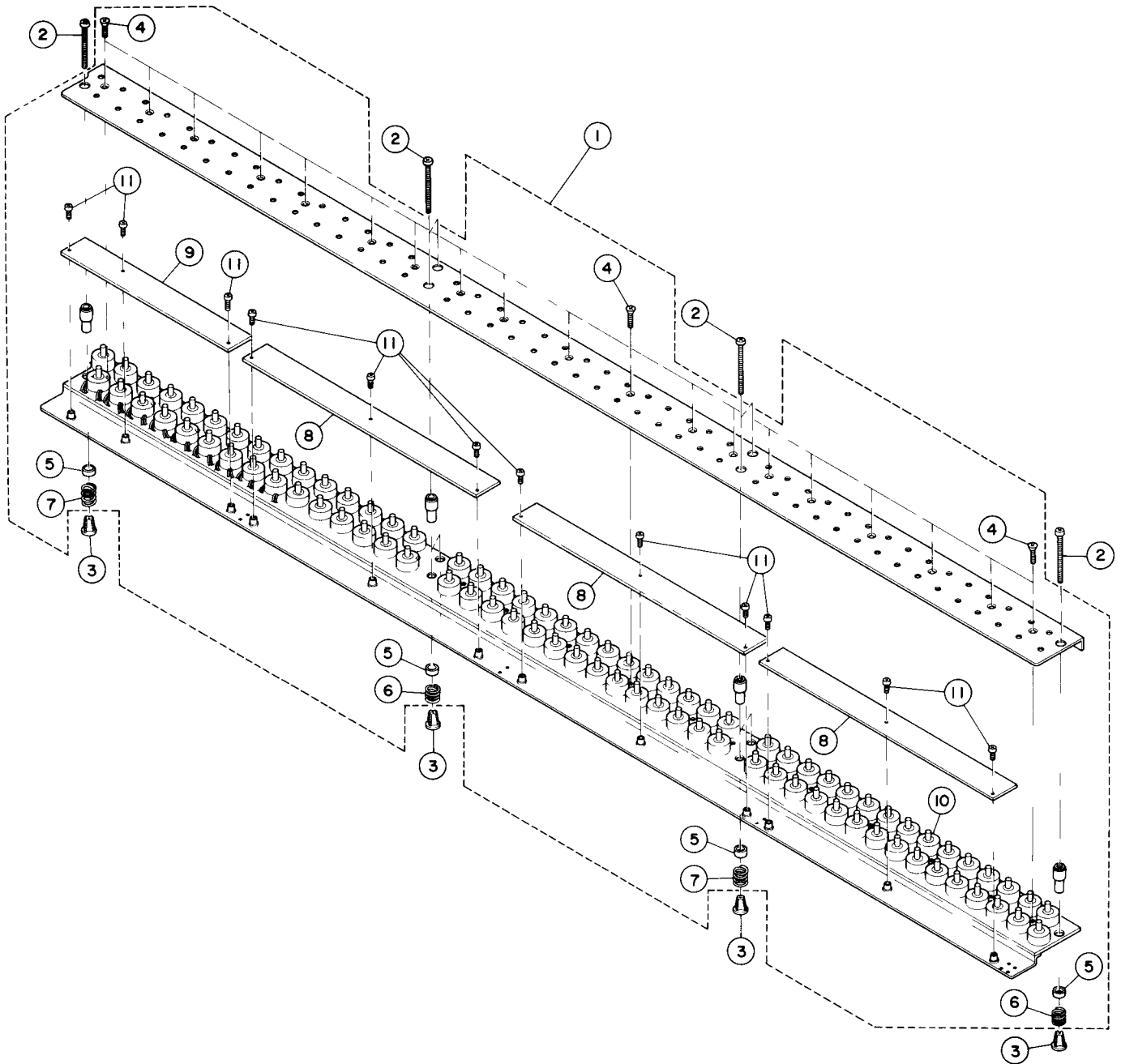

MX80

Ref. No.	Part No.	Description		部 品 名	Remarks
* 1	VH903800	Key Drive Unit		キードライブユニット	U, C
* 1	VJ569800	Key Drive Unit		キードライブユニット	B, E, A
2	EA040556	Pan Head Screw	4x55 YE	ナベ小ネジ	
2	EA040456	Pan Head Screw	4x45 YE	ナベ小ネジ	
3	EX550110	Insert Nut	B4x9.5 YE	鬼目ナット	
3	EZ001490	Insert Nut	D4x20 YE	鬼目ナット	
* 4	EB040186	Flat Head Screw	4x18 YE	皿小ネジ	
* 5	VG927000	Bushing, Spring		スプリング固定ブッシュ	
* 6	VG925300	Cushion Spring (A)	18mm WH	クッションスプリング(A)	Rear
* 7	VG925400	Cushion Spring (B)	22mm YE	クッションスプリング(B)	Front
* 8	VG915200	Circuit Board, Drive (B)	24Key	ドライブ(B)シート	
* 9	VG915300	Circuit Board, Drive (C)	16Key	ドライブ(C)シート	
* 10	VG927100	Coil Ass'y (A)	l=60 BL	PPコイルキット(A)	ODD Key
* 10	VG927200	Coil Ass'y (B)	l=35 WH	PPコイルキット(B)	EVEN Key
* 10	VG967300	Coil Ass'y (AL)	l=75 BL	PPコイルキット(AL)	Key # 1,17,39
* 10	VG967400	Coil Ass'y (EL)	l=50 WH	PPコイルキット(BL)	Key # 40
11	ED030056	Bind Head Screw	3x5 YE	バインド小ネジ	

\* New Parts

### 3. Pedal Drive Unit, Mute Sensor Unit

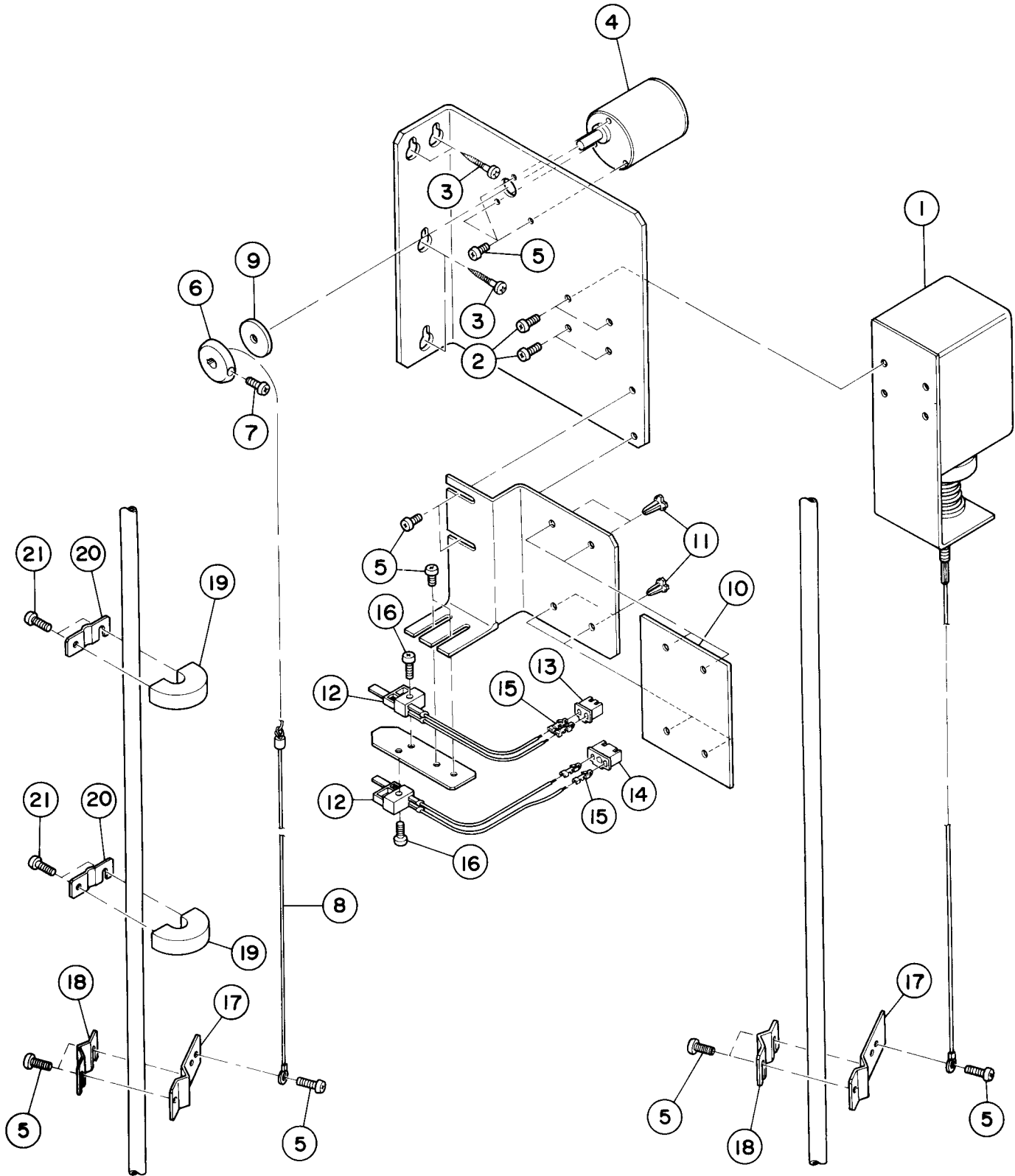

MX80

Ref. No.	Part No.	Description		部 品 名	Remarks
* 1	VG923700	Pedal Solenoid		ペダルソレノイド	
2	ED040166	Bind Head Screw	4x16 YE	バインド小ネジ	
3	EH040166	Truss Head Tapping Screw	4x16 YE	トラスタッピングネジ	
* 4	VH648700	Motor, Mute		ギヤードモーター	
5	ED030066	Bind Head Screw	3x6 YE	バインド小ネジ	
* 6	VG923900	Collar, Mute Motor		モーター用カラー	
7	EJ030106	Pan Head Tapping Screw	3x10 YE	ナベタッピングネジ	
* 8	VG924000	Cord, Mute Motor		モーター巻上げテープ	
* 9	VH222100	Felt Collar		フェルトカラー	
* 10	VG916700	Circuit Board, Connector		ソレノイド中継シート	
11	VC687400	Support	KGLS-3S	サポート	
12	NB037050	Tablet Switch	H	タブレットスイッチ	
* 13	VC013000	Connector Housing, EH Type	2P	EHハウジング	
* 14	VC013100	Connector Housing, EH Type	3P	EHハウジング	
15	VC267600	Contact Pin, EH Type		EHコンタクト	
16	ED030126	Bind Head Screw	3x1.2 YE	バインド小ネジ	
* 17	VG925200	Code Holder		テープ止め金具	
* 18	VG926300	Stopper, Cord Holder		テープ止め金具押え	
* 19	VG926700	Sensor Ring		センサーリング	
* 20	VH470400	Spring, Sensor Ring		センサーリング固定バネ	
21	Ei030066	Bind Tapping Screw	3x6 YE	バインドタッピングネジ	

\* New Parts

### 4. I/O Unit, Power Supply Unit

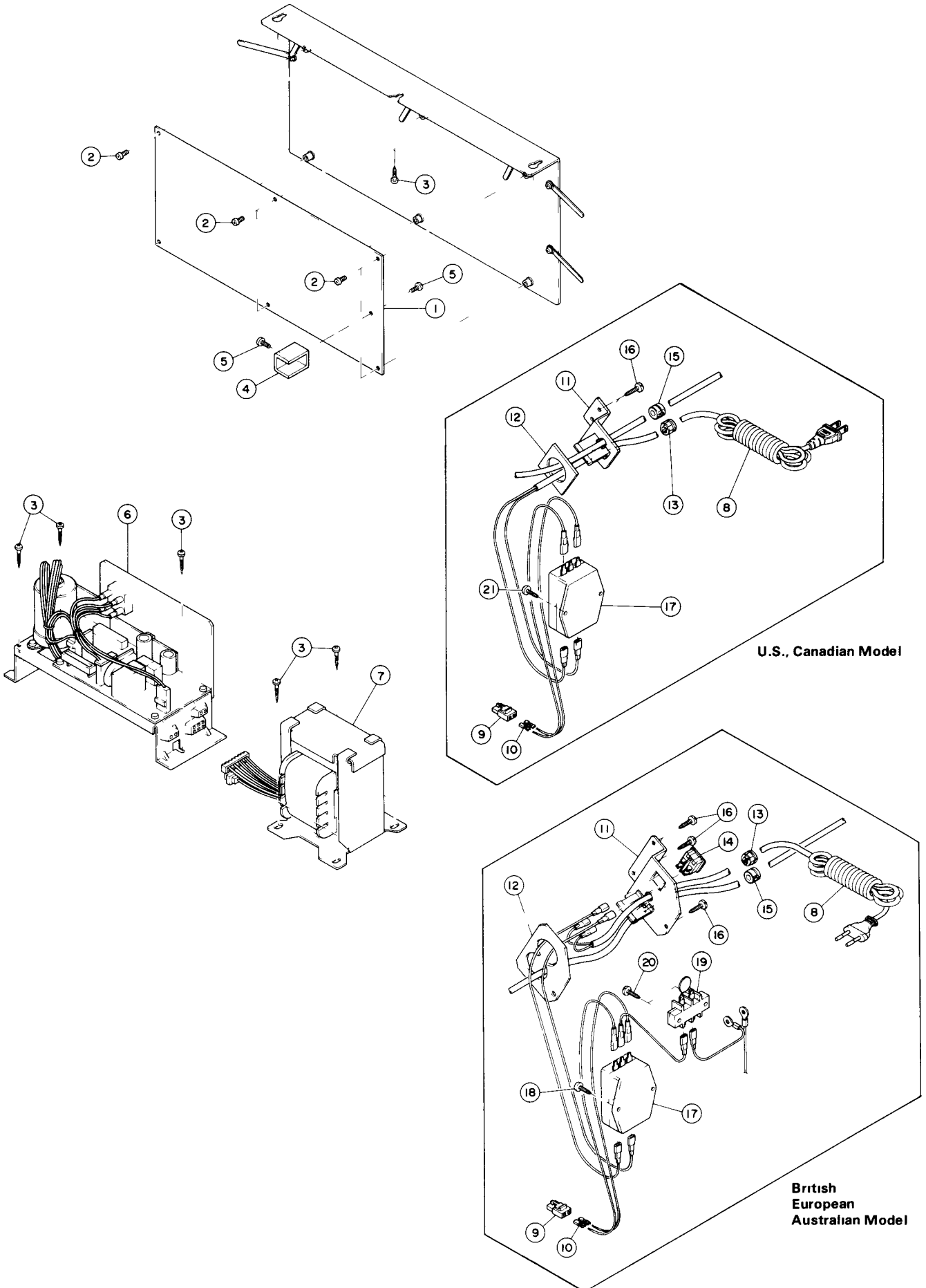

MX80

Ref. No.	Part No.	Description		部 品 名	Remarks
* 1	Vi905500	Circuit Board, I/O		I/O シート	
2	ED030056	Bind Head Screw	3x5 YE	バインド小ネジ	
3	EH040168	Truss Tapping Screw	4x16 YE	トラスタッピングネジ	
4	VH081600	Heat Sink		トランススタ放熱板	
5	ED030056	Bind Head Screw	3x5 YE	バインド小ネジ	
* 6	Vi886100	Power Supply Unit		電源ユニット	U, C
* 6	VJ233900	Power Supply Unit		電源ユニット	B, E, A
* 7	XG592A00	Power Transformer		電源トランス	U, C
* 7	XH614A00	Power Transformer		電源トランス	E
* 7	XH615A00	Power Transformer		電源トランス	B, A
8	MG000820	AC Cord		電源コード	U, C
8	VF757900	AC Cord		電源コード	E
8	VF758000	AC Cord		電源コード	A
8	VH895700	AC Cord		電源コード	B
9	LB201430	Plug, 2P	LP-02	2Pプラグ	
10	LB100670	Contact Pin, LP Type		LPコンタクト	
* 11	Vi881100	Cable Stopper		電源コード止め金具	U, C
* 11	VJ161400	Cable Stopper		電源コード止め金具	B, E, A
* 12	Vi879700	Rubber, Cable Stopper		コード止め金具防振板	U, C
* 12	VJ161600	Rubber, Cable Stopper		コード止め金具防振板	B, E, A
13	VE545300	Bushing, AC Cord	KR-51	コードブッシュ	U, C
13	CB620190	Bushing, AC Cord	CM22B	コードストッパー	B, E, A
14	VH412800	Power Switch	1802	シーソースイッチ	B, E, A
* 15	Vi902100	Bushing	MP5005	スタンダードブッシング	
16	EX550126	Truss Head Tapping Screw	4x1.2 BL	トラスタッピングネジ	
17	VE555800	Noise Filter	PEF-1206-22	ノイズフィルター	
18	Ei330106	Bind Head Tapping Screw	3x10 BL	バインドタッピングネジ	B, E, A
19	VH413000	Terminal	MDH48-2P	2P連結端子台	B, E, A
20	Ei330146	Bind Head Tapping Screw	3x14 BL	バインドタッピングネジ	B, E, A
21	Ei330126	Bind Head Tapping Screw	3x1.2 BL	バインドタッピングネジ	U, C
	LB009090	Connector Housing, XH Type	9P	XHハウジング	CTRL-I/O
	LB101130	Contact Pin, XH Type		XHコンタクト	CTRL-I/O

\* New Parts

5. Key Sensor Unit

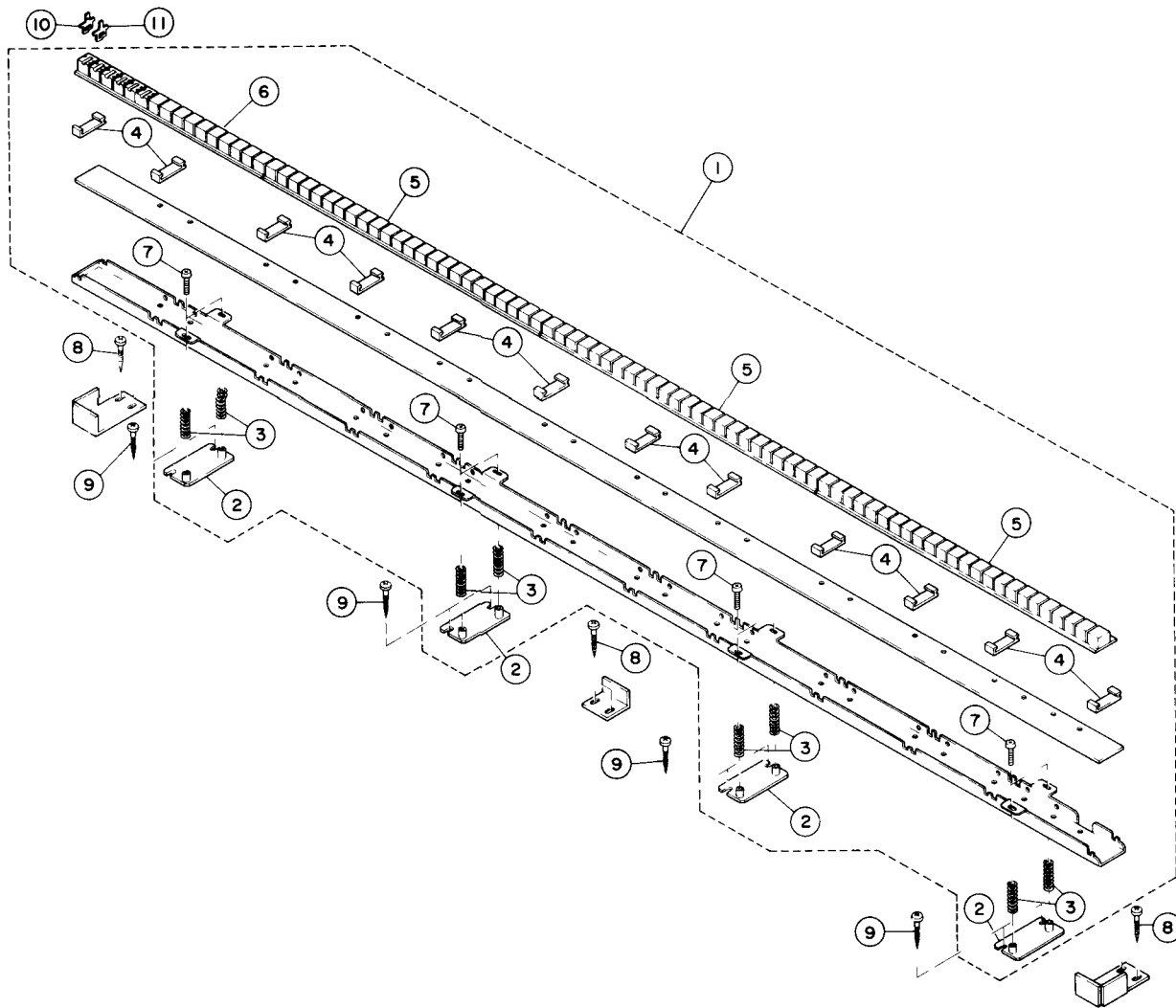

MX80

Ref. No.	Part No.	Description		部品名	Remarks
* 1	VJ233800	Key Sensor Unit		キーセンサーユニット	
* 2	VG918100	Key Sensor Stay		キーセンサーステイ	
* 3	VG918200	Key Sensor Spring		センサー調整バネ	
* 4	VG918400	Holder, Sensor Board		センサーシート止め	
* 5	VG915900	Circuit Board, Sensor (A)		センサーシート(A)	
* 6	VG916000	Circuit Board, Sensor (B)		センサーシート(B)	
7	ED030186	Bind Head Screw	3x18 YE	バインド小ネジ	
8	EH040168	Truss Tapping Screw	4x16 YE	トラスタッピングネジ	
* 9	EX550126	Truss Tapping Screw	4x12 BL	トラスタッピングネジ	
* 10	VG925600	Shutter, White Key		白鍵シャッター	B, E, A
* 10	VH628900	Shutter, White Key		白鍵シャッター	U, C
* 11	VG926100	Shutter, Black Key		黒鍵シャッター	B, E, A
* 11	VH629100	Shutter, Black Key		黒鍵シャッター	U, C

\* New Parts

6. Pedal Sensor Unit

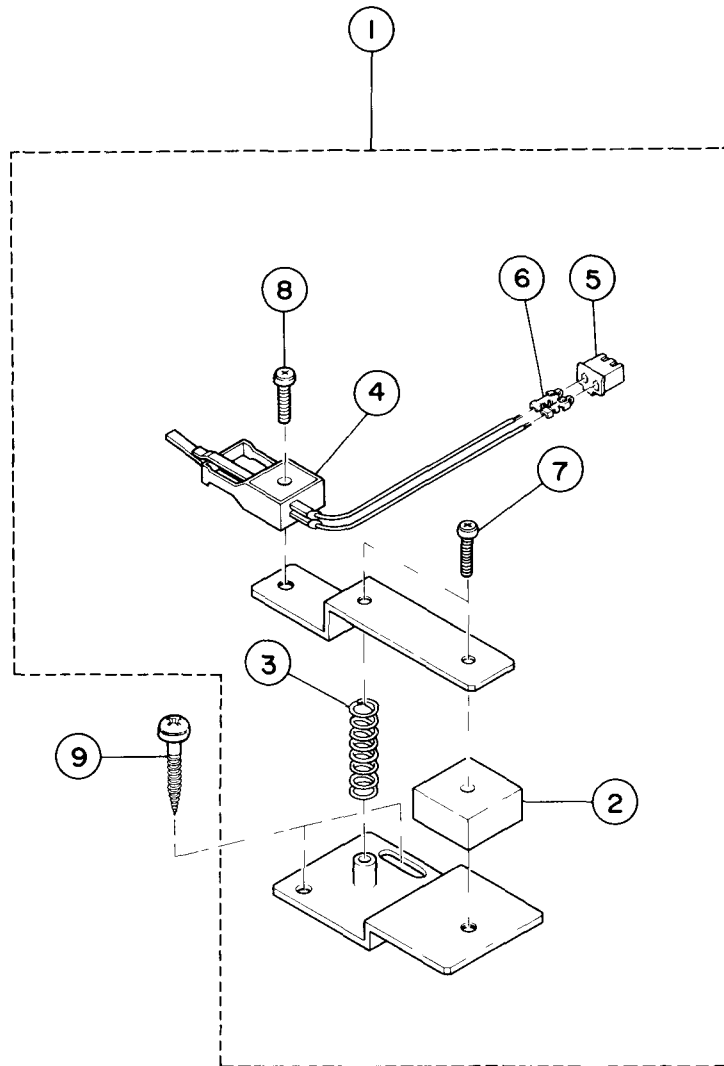

MX80

Ref. No.	Part No.	Description		部品名	Remarks
* 1	VH217100	Pedal Sensor Unit		ペダルセンサーユニット	
* 2	VH445500	Spacer Rubber		ペダルセンサー用ゴム	
* 3	VH445300	Sensor Spring		ペダルセンサー用バネ	
* 4	NB037050	Tablet Switch	M	タブレットスイッチ	
* 5	VC013000	Connector Housing, EH Type	2P	EHハウジング	
6	VC267600	Contact Pin, EH Type		EHコンタクト	
7	ED030166	Bind Head Screw	3x16 YE	バインド小ネジ	
8	ED030126	Bind Head Screw	3x12 YE	バインド小ネジ	
9	EH040168	Truss Tapping Screw	4x16 YE	トラスタッピングネジ	

\* New Parts

MX80 OVERALL CIRCUIT DIAGRAM

MX80

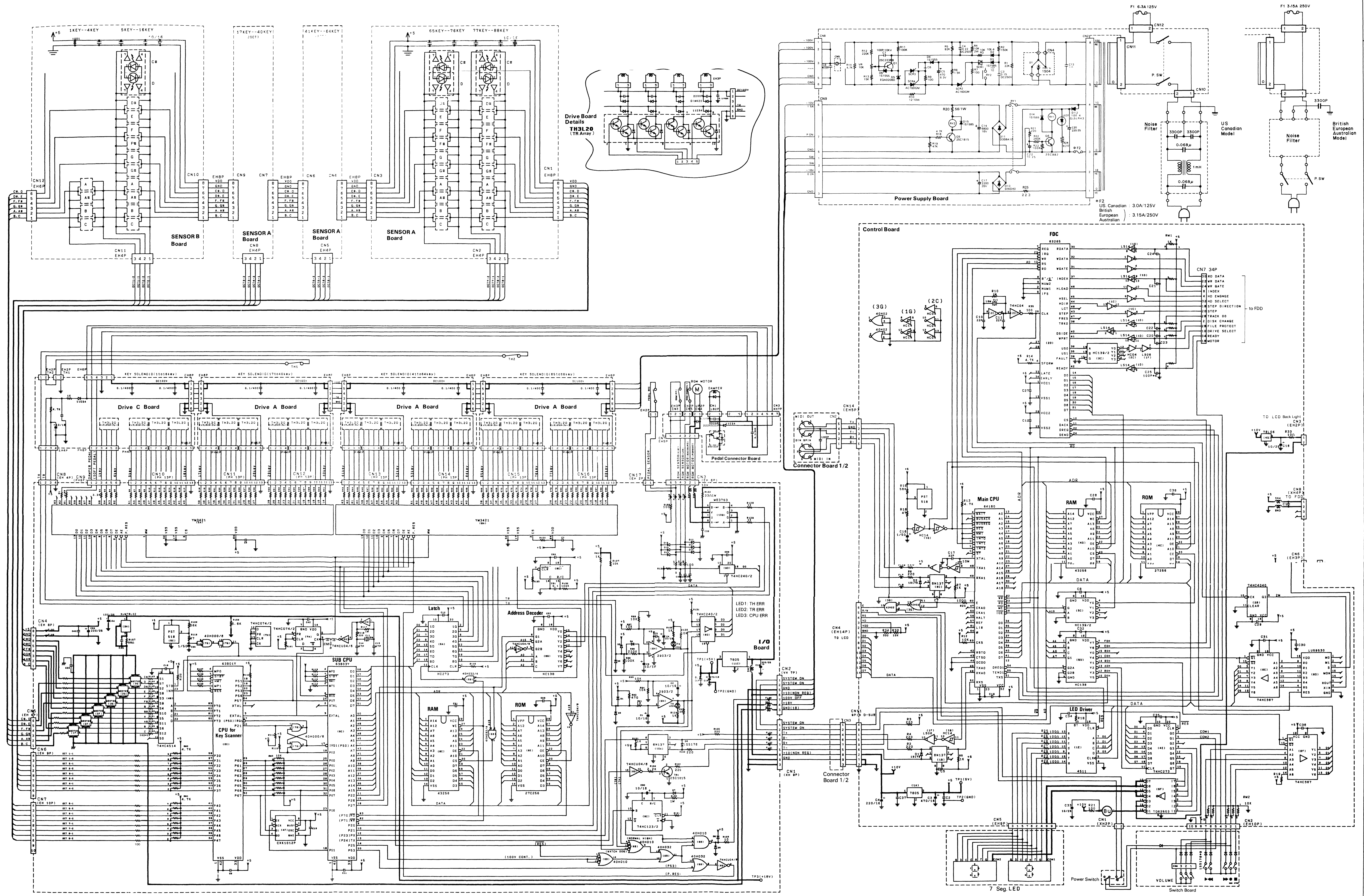

MX80

MX80