

YAMAHA

disklavier

MX-100A

Owner's Manual

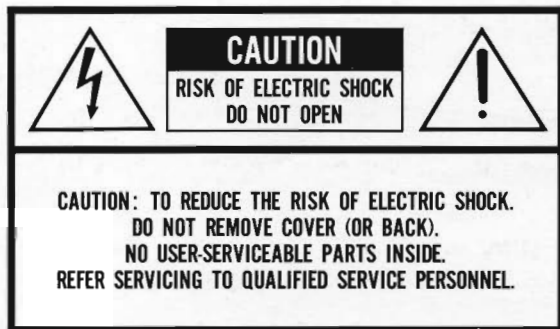

Explanation of Graphical Symbols

The lightning flash with arrowhead symbol, within an equilateral triangle, is intended to alert the user to the presence of uninsulated "dangerous voltage" within the product's enclosure that may be of sufficient magnitude to constitute a risk of electric shock to persons.



The exclamation point within an equilateral triangle is intended to alert the user to the presence of important operating and maintenance (servicing) instructions in the literature accompanying the product.



INFORMATION RELATING TO POSSIBLE PERSONAL INJURY, ELECTRIC SHOCK AND FIRE HAZARD POSSIBILITIES HAS BEEN INCLUDED IN THIS LIST.

WARNING — When using electronic products, basic precautions should always be followed, including the following:

1. Read all Safety and Installation Instructions, Supplemental Marking and Special Message Section data, and any applicable assembly instructions BEFORE using this product.
2. Check unit weight specifications BEFORE you attempt to move this product.
3. Main power supply verification. Yamaha Digital Musical Instrument products are manufactured specifically for use with the main supply voltage used in the area where they are to be sold. The main supply voltage required by these products is printed on the name plate. For name plate location please refer to the graphic in the Special Message section. If any doubt exists please contact the nearest Yamaha Digital Musical Instrument retailer.
4. Some Yamaha Digital Musical Instrument products utilize external power supplies or adapters. Do NOT connect products of this type to any power supply or adapter other than the type described in the owners manual or as marked on the unit.
5. This product may be equipped with a plug having three prongs or a polarized line plug (one blade wider than the other). If you are unable to insert the plug into the outlet, contact an electrician to have the obsolete outlet replaced. Do NOT defeat the safety purpose of the plug. Yamaha products not having three prong or polarized line plugs incorporate construction methods and designs that do not require line plug polarization.
6. **WARNING** — Do NOT place objects on the power cord or place the unit in a position where any one could walk on, trip over, or roll anything over cords of any kind. An improper installation of this type can create the possibility of a fire hazard and/or personal injury.
7. Environment: Your Yamaha Digital Musical Instrument should be installed away from heat sources such as heat registers and/or other products that produce heat.
8. Ventilation: This product should be installed or positioned in a way that its placement or location does not interfere with proper ventilation.
9. Yamaha Digital Musical Instrument products are frequently incorporated into "Systems" which are assembled on carts, stands or in racks. Utilize only those carts, stands, or racks that have been designed for this purpose and observe all safety precautions supplied with the products. Pay special attention to cautions that relate to proper assembly, heavier units being mounted at the lower levels, load limits, moving instructions, maximum usable height and ventilation.
10. Yamaha Digital Musical Instrument products, either alone or in combination with amplification, headphones, or speakers, may be capable of producing sound levels that could cause permanent hearing loss. Do NOT operate at high volume levels or at a level that is uncomfortable. If you experience any discomfort, ringing in the ears, or suspect any hearing loss, you should consult an audiologist.
11. Do NOT use this product near water or in wet environments. For example, near a swimming pool, spa, in the rain, or in a wet basement.
12. Care should be taken so that objects do not fall, and liquids are not spilled into the enclosure.
13. Yamaha Digital Musical Instrument products should be serviced by a qualified service person when:
 - a. The power supply/power adapter cord or plug has been damaged; or
 - b. Objects have fallen, or liquid has been spilled into the products; or
 - c. The unit has been exposed to rain; or
 - d. The product does not operate, exhibits a marked change in performance; or
 - e. The product has been dropped, or the enclosure of the product has been damaged.
14. When not in use, always turn your Yamaha Digital Musical Instrument equipment "OFF". The power supply cord should be unplugged from the outlet when the equipment is to be left unused for a long period of time. NOTE: In this case, some units may lose some user programmed data. Factory programmed memories will not be affected.
15. Electromagnetic Interference (RFI). Yamaha Digital Musical Instruments utilize digital (high frequency pulse) technology that may adversely affect Radio/TV reception. Please read FCC Information (page 35) for additional information.
16. Do NOT attempt to service this product beyond that described in the user maintenance section of the owners manual. All other servicing should be referred to qualified service personnel.

PLEASE KEEP THIS MANUAL FOR FUTURE REFERENCE!

Thank you for purchasing the Yamaha Disklavier. This newly developed device is a highly musical performance system that combines Yamaha's advanced electronics technology with our decades of experience in manufacturing musical instruments.

In order to be able to make full use of the Disklavier's large variety of functions and superior performance as well as to obtain many years of trouble-free enjoyment, please read this instruction manual carefully.

FEATURES

- Using micro-floppy disks as a recording medium, this digital device plays the piano itself during playback, thus ensuring that tonal irregularities, noise and distortion are completely avoided.
- Even the most delicate nuances of touch, from pianissimo to fortissimo, are faithfully recorded and reproduced.
- During playback, volume and tempo adjustment as well as transposition can be carried out as desired. Changing the tempo does not influence the pitch.
- Speedy music selection as well as "fast forward" and "rewind" operations.
- Playing simultaneously with the playback of recorded music is possible.
- A metronome function is built in, thus making it possible to record or practice while listening to the metronome sound.
- The repeat function allows repeated playback of selected music.
- Separate recording and playback of the parts for the left and right hand is also possible.
- MIDI functions are built in. This means that an external MIDI instrument may be played automatically during playback as well as allowing a large variety of MIDI control configurations using sequencers and rhythm machines.

The Disklavier Design

The Disklavier consists of a control unit and a drive unit comprising of a sensor unit, solenoid units, power source unit and I/O control unit.

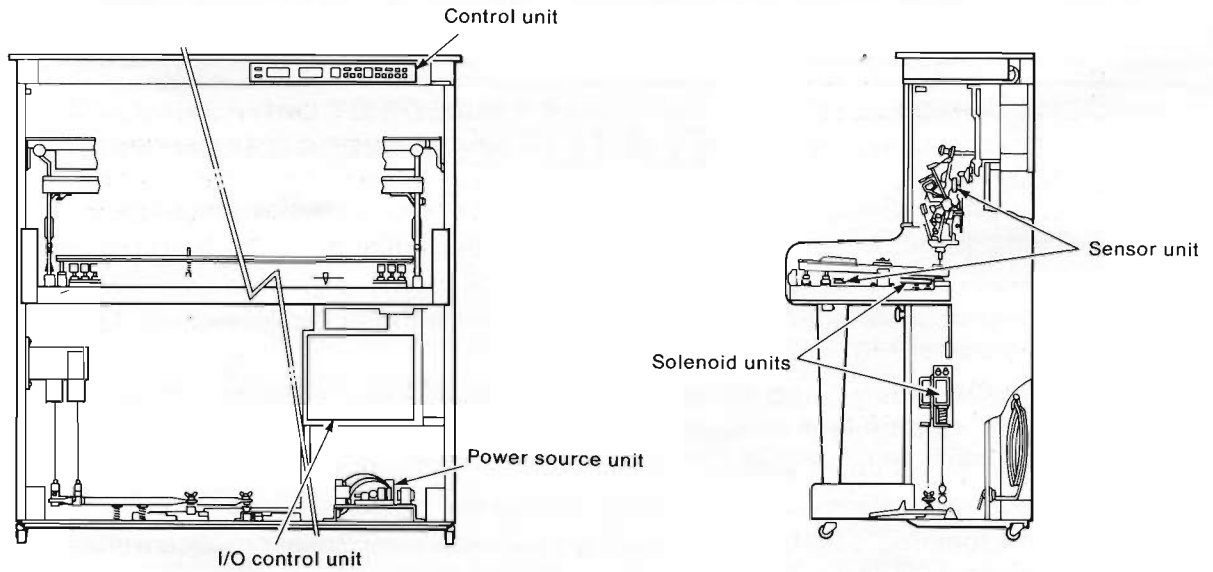

Contents

Before Using Your Disklavier	3	Playback Functions	23
Remote Control Unit Battery Installation	4	Return-FF	23
Playback	5	Playback Pause	23
Names and Functions	8	Altering the Tempo	23
Front Panel	8	Transposition	23
Remote Control Unit	11	Repeat Playback	24
Connectors	13	Return and Stop	25
Floppy Disks	14	Playing Back Music Separately for	
Types of Floppy Disks	14	the Left and Right Hand	25
Handling	14	Playing Back Ensemble Music	26
Recording Erasure Protection	14	Additional Functions	27
Formatting	14	Input of Music and Disk Titles	27
Erasing a Recording	15	Using the Metronome Function Alone ...	30
Convert	16	Deleting Single Pieces of Music	31
Recording	17	MIDI Functions	31
Recording Functions	19	Specifications	32
Record Pause	19	Warning Displays and Error Messages	33
Recording Music Separately for		Troubleshooting	34
the Left and Right Hand	19	FCC Information	35
Recording with Metronome	20		
Rerecording	22		
Recording Ensemble Music	22		

Before Using Your Disklavier



Location

Please avoid using your Disklavier in the following locations as this may lead to malfunctions or damage.

- Near windows and other places exposed to direct sunlight.
- Extremely hot locations such as next to heating appliances.
- Extremely moist or dry places.
- Locations exposed to dust or vibrations.



AC Power Connection

- Disconnect the Disklavier from the AC receptacle when not using it for an extended period of time.



Floppy Disks

Please handle floppy disks with care. (See page xx.)



Do Not Open the Piano's Front Panel!

Please do not open the front panel. If necessary, contact a qualified serviceman.



Handle With Care!

- Do not use excessive force when operating switches and buttons. Avoid pressure on the cabinet.
- Do not place anything on top of the cabinet.
- Take care that cords and cables do not get stuck under the piano.
- Be sure to turn off the power when inserting or removing cords and cables.
- In order to prevent short circuits and wire breakage, always disconnect cords by pulling them out by their plugs.



Do Not Open the Cabinet!

Opening the cabinet and inserting hands or tools can cause both damage and accidents. If something has dropped into the cabinet, disconnect the power cable and contact your dealer.



Beware of Lightning!

During thunderstorms when there is the danger of lightning strikes, disconnect the power plug.



In Case of Water Leakage...

In case the Disklavier has been rained upon or a vase spilled on it, disconnect the power cable and contact your dealer.



Relocation

When relocating or moving the Disklavier, be sure to disconnect all cords and cables so as to avoid short circuits and wire breakage.



Cleaning

- Clean the exterior with a soft, dry cloth.
- Wiping the exterior with benzene, thinner or similar chemicals or using aerosols near it may damage the finish and should be avoided.



Interference Noise in Other Appliances

• The Disklavier uses digital circuitry throughout so it may cause interference noise in radios, television sets, etc., when these are used very close to the unit at the same time. Therefore be sure to keep some distance to such appliances.



Check Again!

When you think there is something wrong with the Disklavier, please check the items listed on p.34 under "Troubleshooting". You may have made a mistake during operation that can be corrected easily.

Remote Control Unit Battery Installation

Use the supplied remote control transmitter unit after having inserted the two supplied UM-3 batteries. Operation during playback is easier with the remote control than with the buttons on control unit. For details, see "Names and Functions".

Inserting the Batteries

① Remove the battery cover from the bottom of the remote control.

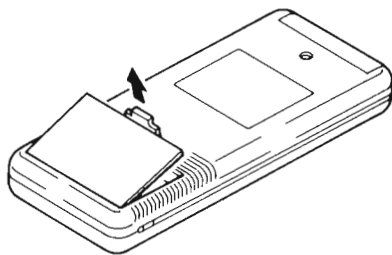

② Insert the two batteries, making sure that (+) and (-) are correctly aligned.

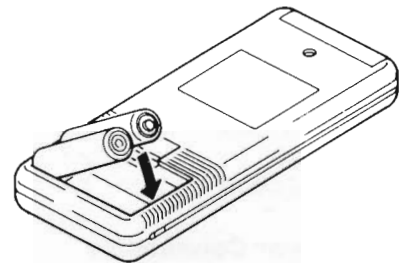

③ Reinstall the battery cover.

Notes:

- Please make sure that the (+) and (-) poles of the batteries correspond to the schematic drawing in the battery compartment.
- When the remote control can no longer be used from greater distances, replace the batteries.
- Replace the batteries with two new ones of the same type.
- When not using the remote control unit for extended periods, remove the batteries in order to prevent damage from leakage.

Playback

First, enjoy playing back the music on the provided floppy disk.

① Connections

Connect the power cable to an AC receptacle.

② Switch on the power.

Pressing the power switch calls up the following message on the front panel liquid crystal display (LCD).

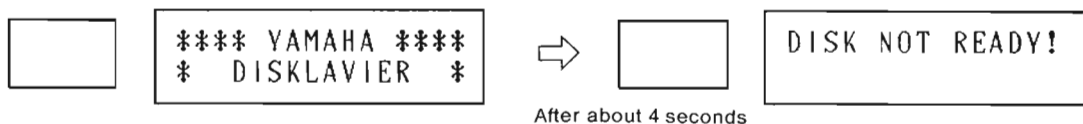

③ Insert the floppy disk.

Carefully insert the supplied floppy disk into the Disklavier in the direction of the arrow with the label facing upward.

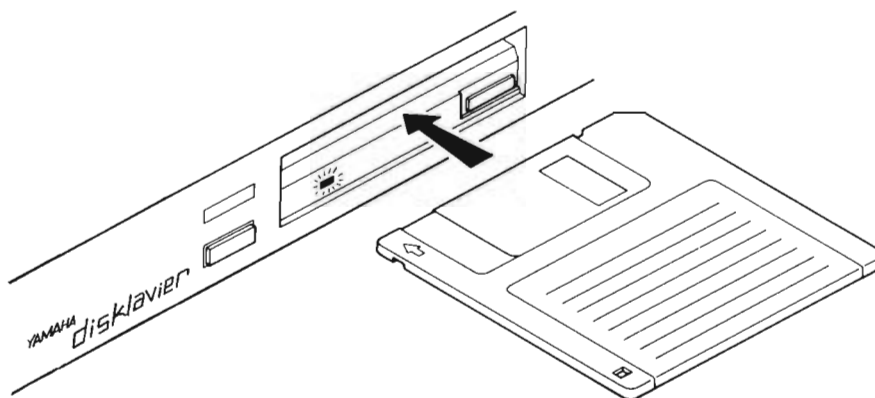

After the floppy disk has been inserted, the display will show the following messages.

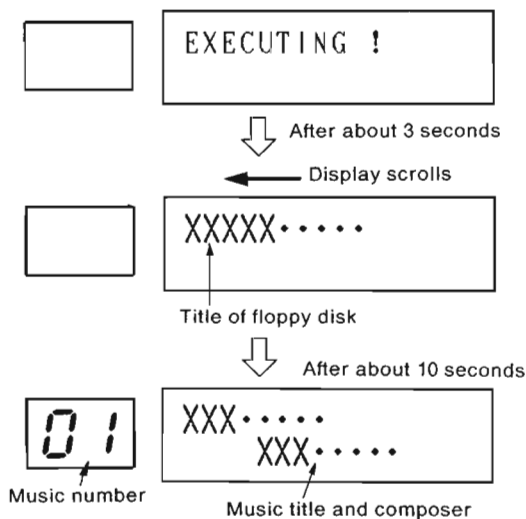

④ **Select the music.**

Select the music you wish to play back. Press the buttons until the number and title of the desired music are displayed.

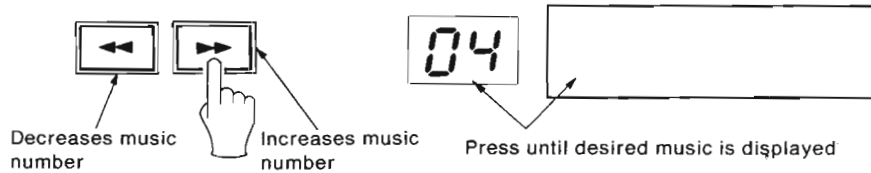

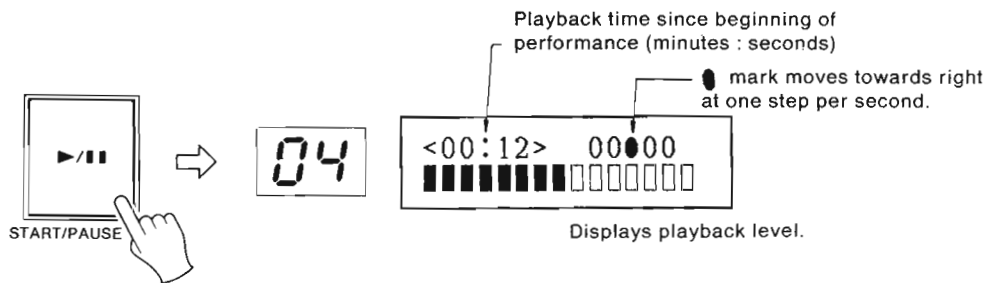

⑤ **Start playback.**

Press the Start/Pause button to start playback. When the music starts, the "time since beginning of performance", "one second count" and "playback level" are displayed on the LCD.



⑥ **Volume adjustment**

To adjust the volume, first make sure that the indicator on the Volume button is on, then use the  and  buttons to achieve the desired listening level. If the Volume button indicator is not lit, press this button to turn it on before carrying out adjustment. During volume adjustment, the display will change as follows.

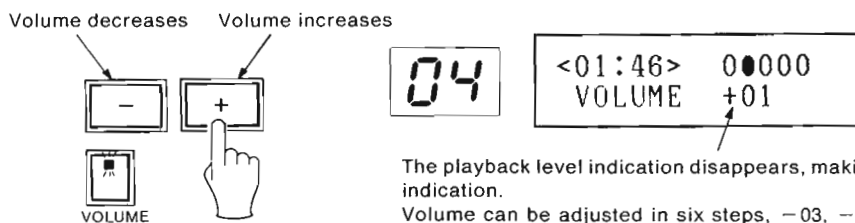

The playback level indication disappears, making way for volume indication.

Volume can be adjusted in six steps, -03, -02, -01, 00, +01, +02. (Approximately 10 seconds after completing volume adjustment, the display will revert to level indication.)

⑦ **Stopping playback.**

Playback continues until the last piece of music has been played. If you wish to stop a performance during playback, press the Stop button.

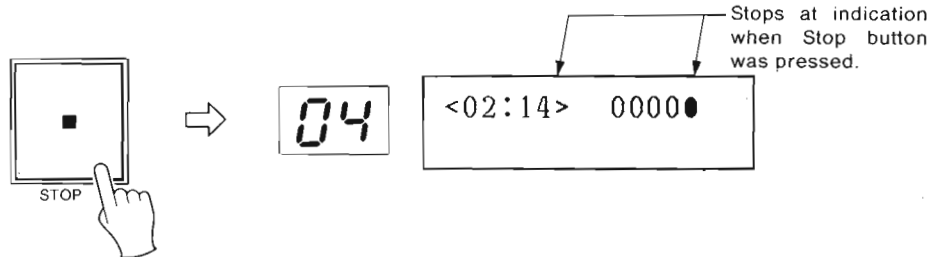

In this condition, the Music Selection/Return/FF buttons may be used again to select a piece of music. Try playing back various numbers.

⑧ **After using the Disklavier...**

After having used your Disklavier, press the Stop button to enter stop mode, then press the Disk Eject button in order to remove the disk, and finally press the power switch to turn it off. When you do not intend to use your Disklavier for any length of time, also disconnect the power cord from the AC receptacle.

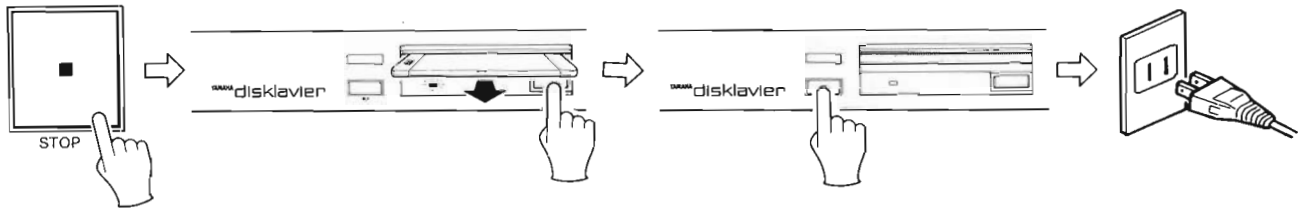

* **There are many other playback functions still to discover. Please read the sections "Names and Functions" and "Playback Functions".**

Names and Functions

● Front Panel

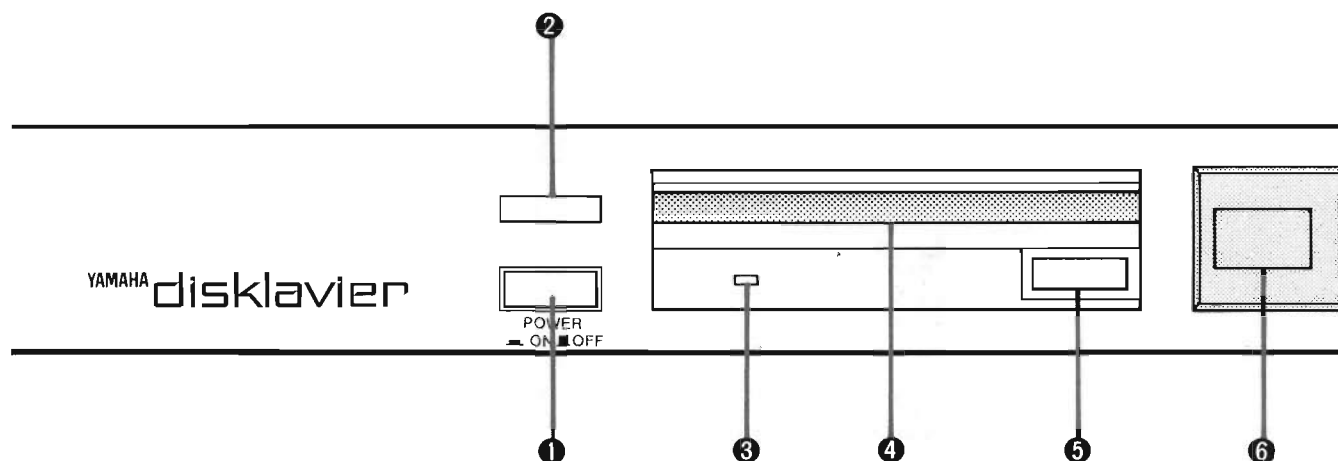

① Power switch

Pressing this switch turns power on, shown by the power indicator ③ and the Volume button indicator ⑬ lighting up. At the same time, the LCD will display the message "DISK NOT READY!".

② Remote control signal window

The infrared signals from the remote control unit are received at this window. Be sure to leave it uncovered so the signals from the remote control unit can be received properly.

③ Power indicator

Lights up when power is turned on.

④ Disk slot

Floppy disks are inserted here.

⑤ Disk Eject button

Press this button when you wish to remove an inserted disk.

* Please do not remove the disk during playback or recording as this will damage the disk drive head and the disk itself.

⑥ Music number indication

Displays the number of the selected piece of music. Confirm this display before you play back or record.

⑦ Liquid Crystal Display (LCD)

The LCD displays a variety of information such as the music title, adjustment values, the time that has elapsed since the beginning of the piece of music, playback and recording levels, and so on.

⑧ Start/Pause button

Press this button when you want to start playback or recording. Also use it when you wish to temporarily stop (pause) or restart a piece of music during playback or recording. (If this button is pressed during fast forward or rewind, playback will recommence from there.)

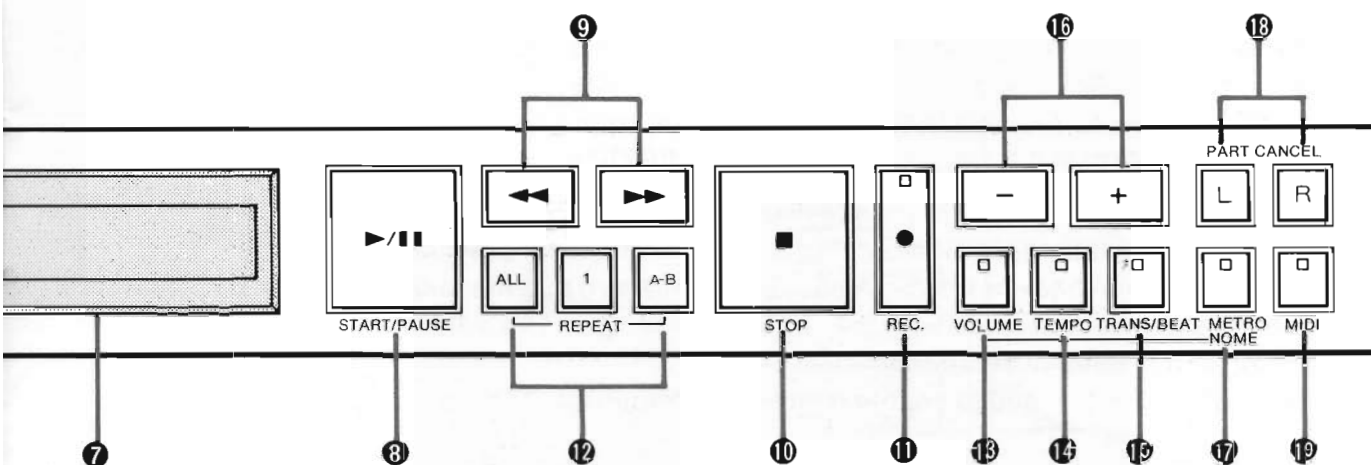

9 Tune Select/Return-FF buttons

In stop or record stand-by mode, the function of these buttons is to select the music number, while they function as Fast Forward or Return buttons during playback. To stop fast forward or rewind operation, press the respective button again. This will restart playback from the point where the button was pressed. If the button is not pressed again, fast forward or Return will stop at the beginning of the next piece of music or the present one respectively.

10 Stop button

This button stops all operations such as playback and recording, fast forward or rewind.

11 Rec. button

Pressing this button causes its indicator to light up, entering record stand-by mode. Recording can now be started by pressing the Start/Pause button.

If you would like to delete part of a recorded piece of music and rerecord something else in its place, first enter record stand-by mode by pressing this button. Then display the number of the respective piece of music with the Music Selection/Return-FF buttons 9 and use the Start/Pause button 8 in order to commence rerecording.

- ★ The number of pieces of music that can be recorded on a single floppy disk is 60 for a total recording time of about 90 minutes. However, this is only an approximation and the actual number of pieces and length of recording time depends on the kind of music recorded.
- ★ If this button is pressed once again during record stand-by mode, the mode will change to "music/disk title entry mode", which is used to input the names of single pieces of music or entire disks. (See the section on "Input of Music and Disk Titles" on page 27.)
- ★ If this button is pressed again twice during record stand-by mode, the mode will change to "split point setting for separate left- and right-hand parts". (See the section on "Recording Music Separately for the Left and Right Hand" on page 19.)

12 Repeat buttons

Operate these buttons when you desire repeated playback of certain pieces of music or sections within them. (See the section on "Repeat Playback" on page 24.)

13 Volume button

In order to adjust the playback volume, press this button in stop mode, during playback or playback pause, making sure that the button's indicator lights up. You can then adjust the volume with the +/– buttons **16**. The adjustment range is from –03 to +02. It is usually set to 00. In addition, this button can be used to turn the metronome sound on or off when the Metronome button **17** has been pressed to select the metronome function.

14 Tempo button

When you want to adjust the tempo (speed) of a piece of music for playback, press this button in stop mode, during playback or playback pause, making sure that the button's indicator lights up. You can then adjust the tempo with the +/– buttons **16**. The adjustment range is from –50% to +20%. It is usually set to 00.

Besides, this button can be used to enable metronome tempo adjustment when the metronome function is on.

15 Trans/Beat

When you want to transpose (change) the key of a piece of music for playback, press this button in stop mode, during playback or playback pause, making sure that the button's indicator lights up. You can then transpose the music with the +/– buttons **16**. The transposition range is from two octaves down to two octaves up. It is usually set to “normal”.

In addition, this button can be used to set the metronome time when the metronome function is on.

16 – / + buttons

These are used for various adjustments and settings such as volume, tempo or transposition. Pressing the “–” button decreases the respective value, pressing “+” increases it. With both buttons, keeping them depressed changes the value continuously while pressing them shortly changes the value in single steps.

17 Metronome button

The Disklavier has a metronome function which allows you to record music while listening to a metronome beat. It is also possible to use the metronome function when not recording. (However, the metronome cannot be used during playback.)

When you wish to use the metronome function, press this button. (On how to adjust the metronome tempo and set the time, see page 20.)

18 Part Cancel buttons

It is possible to cancel either the left-hand or right-hand part by pressing the corresponding Part Cancel button when playing back music recorded separately for the left and right hand. In other words, pressing the button “L” causes only the sound of the keys played by the right hand to be heard, while pressing “R” means that you will hear only the part for the left hand. This function can be used only with pieces of music which have been recorded according to the method described under “Recording Music Separately for the Left and Right Hand” on page 19. This button is also used when you wish to select the part you want to play back in the case of ensemble music.

19 MIDI button

This button is only needed when MIDI signals are being exchanged with other connected MIDI equipment. Pressing this button enters MIDI set-up mode in which the conditions for MIDI communication are established.

★ Should you wish to use MIDI functions, please refer to the separate “MIDI Handbook”.

● Remote Control Unit

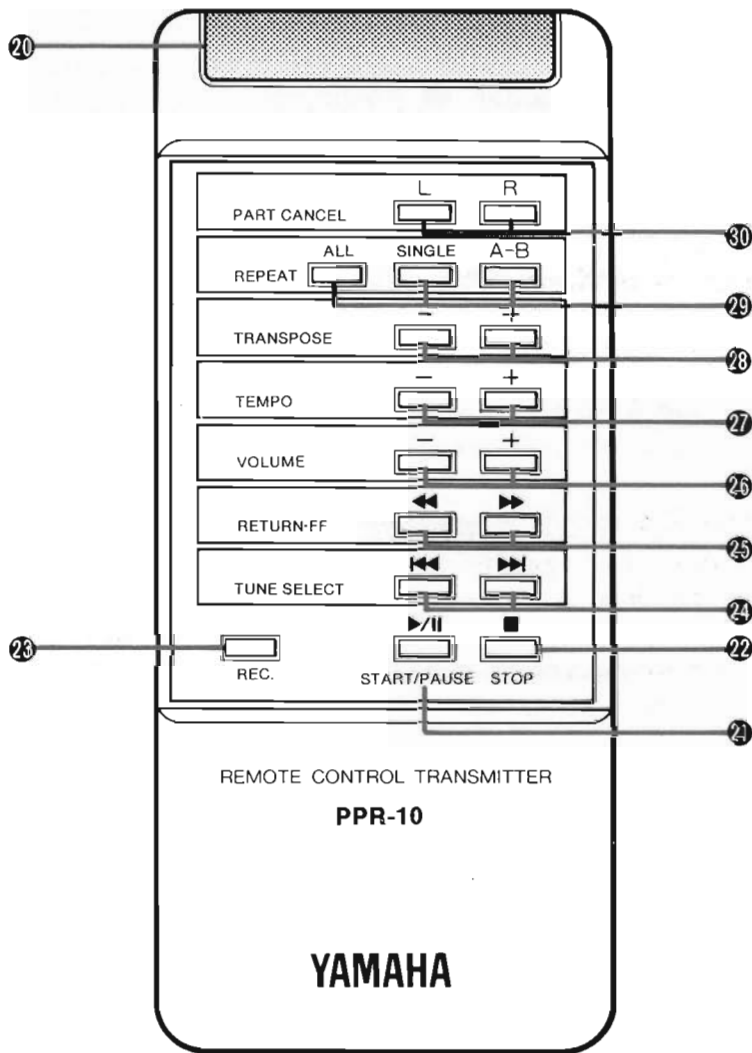

② Remote control signal window

Please operate the remote control while making sure that this infrared signal transmission window is aimed at the corresponding reception window ② on the front panel. The control signals from the remote control unit are transmitted from here.

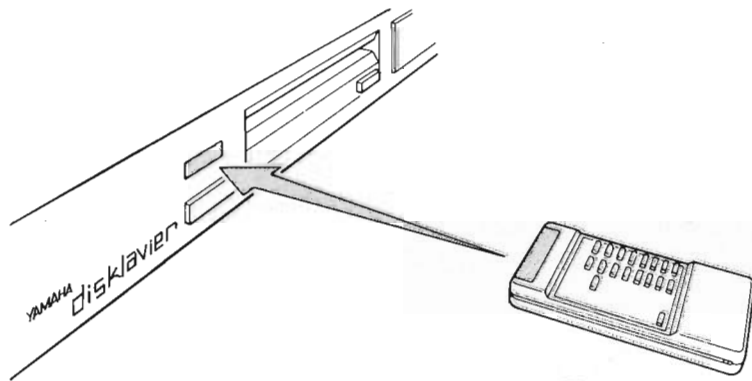

21 Start/Pause button

Has the same functions as the Start/Pause button **8** on the front panel.

22 Stop button

Has the same functions as the Stop button **10** on the front panel.

23 Rec. button

Has the same functions as the Rec. button **11** on the front panel.

24 Tune Select buttons

The function of these buttons is to select the music number in stop mode, during playback or in record stand-by mode.

25 Return-FF buttons

These buttons are for fast forward and rewind. They can be operated in stop mode or during playback. Fast forward or rewind continues until the respective button is pressed again.

26 Volume buttons

These buttons adjust playback volume level. They can be operated in stop mode, during playback or playback pause.

27 Tempo buttons

When you want to adjust the tempo of a piece of music for playback, use these buttons in stop mode, during playback or playback pause.

28 Transpose buttons

When you want to transpose (change the key of) a piece of music for playback, press these buttons in stop mode, during playback or playback pause.

29 Repeat buttons

Operate these buttons when you desire repeated playback. (See the section on "Repeat Playback" on page 24.)

30 Part Cancel buttons

These allow you to cancel either the left-hand or right-hand part for playback of music with separate parts for the left and right hand.

★ Operations that cannot be carried out with the remote control unit:

- Operations with the metronome function on
- Operations in MIDI set-up mode
- Disk formatting, registration

● Connectors

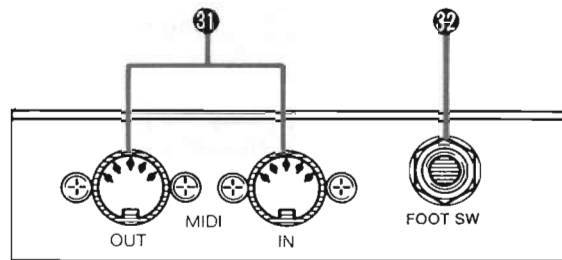

③① MIDI jacks

These jacks are used for MIDI connections. When you want to control other MIDI equipment from the Disklavier or control this unit via other MIDI equipment, these jacks enable MIDI signal communication. (Please refer to the separate “MIDI Handbook” for more information on MIDI functions.)

③② Foot switch jack

If an optional FC-5 foot switch has been connected to this jack, you can start, stop and restart playback or recording with your foot. (The foot switch then has the same functions as the Start/Pause button ⑧ on the front panel.)

Floppy Disks

Floppy disks are a data storage medium using a film coated with magnetic material. Since this magnetic surface is very delicate, please take care when handling floppy disks.

● Types of Floppy Disks

- There are various types of floppy disks available. When purchasing floppy disks for recordings with your Disklavier, please ask for double sided, double density, double track 3.5 inch floppy disks. (We recommend MF2DD disks.)
- Floppy disks must be inserted in the correct direction with the right side up. Please insert them as shown in the illustration on page 5.
- Floppy disks which have been formatted on the Disklavier can be used for recording up to 90 minutes of music per disk (depending on the recording conditions).

● Handling

- Do not slide open the shutter and touch the disk's magnetic surface. Also protect the disk from smoke and aerosols. If the magnetic surface gets soiled or damaged, the disk may become unusable.
- Please use the disk in a comparatively dust-free environment.
- Avoid placing disks near television or radio sets, speakers or other devices generating magnetic fields.
- Disks can be used in the environmental temperature range from 4°C to 52°C. Please do not store them where it gets colder than 4°C or hotter than 52°C.

● Recording Erasure Protection

If the erasure protection tab is slid in the direction shown by the arrow in the following illustration, recording becomes impossible with that floppy disk. You can thus protect valuable music data recordings from accidental erasure.

By returning the erasure protection tab to its original position, you can record again on that disk.

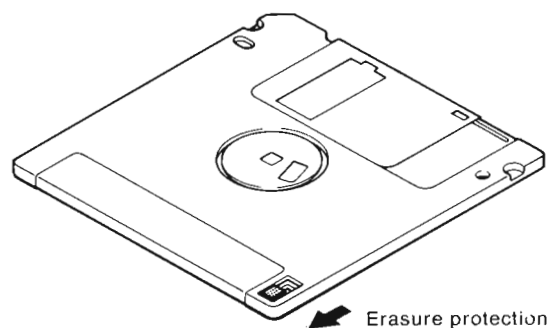

● Formatting

In order to be able to use newly purchased disks with the Disklavier, they first have to be "formatted".

In other words, only disks that have been properly formatted can be used for recording. It is not necessary to format the supplied disk. (Doing so would erase the recorded music!)

— How to Format Disks —

- ① After inserting a disk, press the Rec. button while keeping the Stop button depressed. You can release these buttons when the display reads "FORMAT OK?".

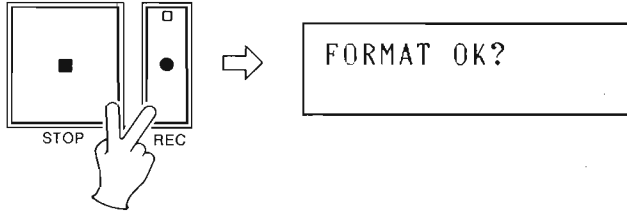

- ② In answer to the above message, press the Start/Pause button. (If you should decide not to proceed with formatting, remove the disk instead.)

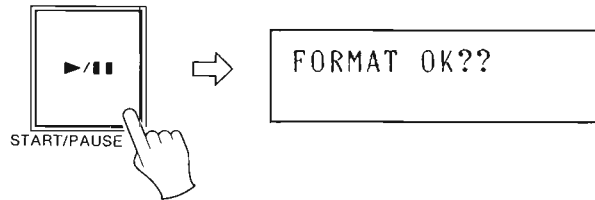

- ③ Reconfirm the above question by again pressing the Start/Pause button. (If you decide not to proceed with formatting, remove the disk instead.)

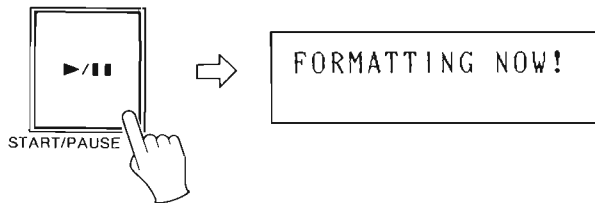

- ④ After a few minutes, formatting is completed and the display will change as follows.

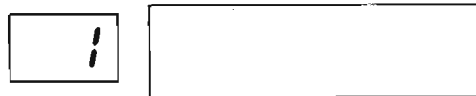

● Erasing recordings

Should you wish to delete all recordings on a disk at once, you can format that disk as described.

● Convert

In order to play back data that have been recorded on another system such as the Yamaha MIDI recorder YRM-301 (MSX), the "Convert" procedure described below must be carried out. (For details, see the MIDI Handbook, 3-7 "Data Compatibility".)

Doing so enables not only playback, but recording as with other formatted disks.

- ① Insert the disk. The following message will appear.



- ② While keeping the  button depressed, press the Stop button. Let go of the button when the display shows "Convert OK?"



- ③ In answer to the above message, press the Start/Pause button. (If you should decide not to proceed with conversion, remove the disk instead.)

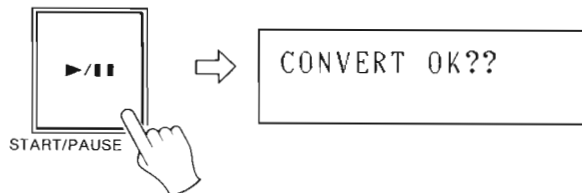

- ④ Reconfirm the above question by again pressing the Start/Stop button. (If you decide not to proceed with conversion, remove the disk instead.)

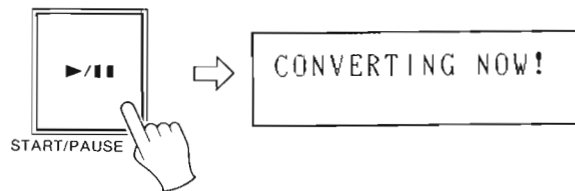

- ⑤ After about thirty seconds, conversion is completed and the display will change as follows.



The name of the first file is displayed on the lower line.

Recording

We will now make a recording. Have a new floppy disk ready.

① Preparation for recording

In preparation for recording, first carry out the basic steps described on page 5 under "Playback", that is, make the proper connections, turn on the power and insert the floppy disk. Should one of the following messages appear on the display after the disk has been inserted, carry out the necessary operations indicated by the message.

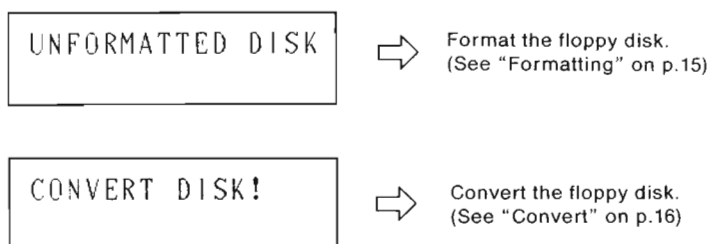

② Record stand-by mode

Press the Rec. button to enter record stand-by mode. Entering this mode calls up the display shown below.

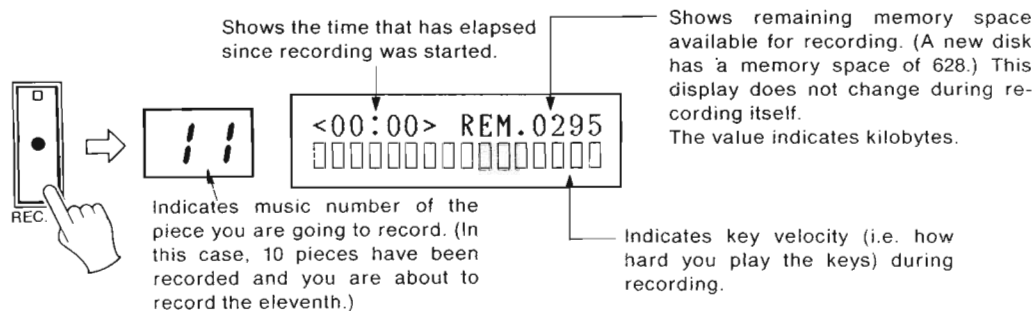

If the following message appears on the display, slide back the erasure protection tab on the floppy disk. (See page 14 for details on "Recording Erasure Protection".)



③ Various function settings

If necessary, set the split point for pieces with separately recorded left and right hand parts, turn on the metronome function or select the number of a piece you wish to rerecord. (See the following section on "Recording Functions".)

④ Start recording

Start recording by pressing the Start/Pause button. Doing so will produce a beeping sound which is the signal for you to start playing.

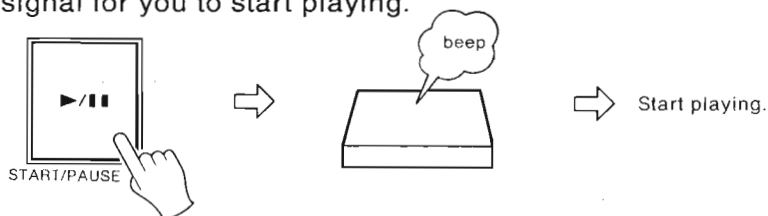

★ As soon as the beep sound is heard, the time display count will commence on the LCD. However, recording itself will not start until you begin to play. There is therefore no need to rush and start playing immediately. Please note though that only pauses of up to twenty seconds will be cut out completely in the recording, while longer pauses will remain as blanks. Also note that a blank of two seconds is automatically inserted at the beginning of each piece of music during playback.

● During recording

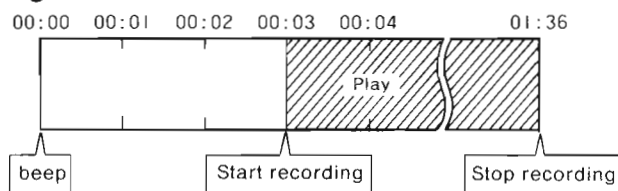

● During playback

Blank spaces at the beginning are cut and playback begins after two seconds.

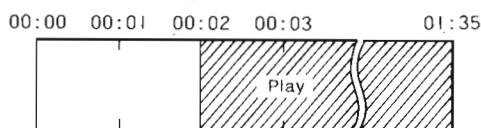

⑤ Stop recording

After you have finished your performance, press the Stop button. The message "EXECUTING!" is displayed, and after two or three seconds, the music number of the recorded piece appears, indicating that recording has been completed.

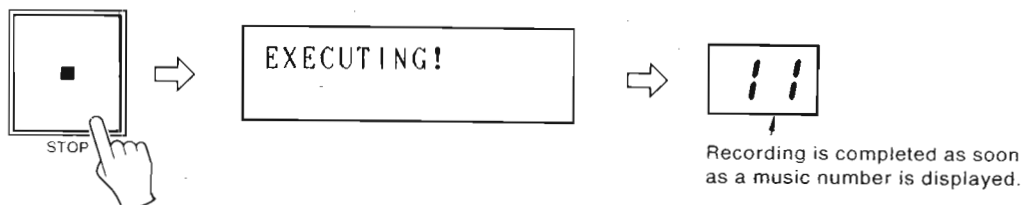

★ Please do not remove the disk or pull out the power plug during recording. Doing so would call up the message "FILE NOT FOUND! RE-CONVERT DISK!", and the music you were playing would not be recorded. (See page 33.)

⑥ Music title input

If necessary, you can input the title of the recorded piece of music. (See page 27 for instructions.)

Recording Functions

This section introduces various functions that have to do with recording.

Record Pause

If the Start/Pause button is pressed during recording, recording is halted temporarily, entering record pause mode. Pressing the Start/Pause button again in this mode allows you to restart recording. However, any blank spaces (without any recording) between the end of the previous and the beginning of the new recording will not be cut out.

Recording Music Separately for the Left and Right Hand

Designating a split point (i.e. the position on the keyboard dividing the sections for the left and right hand) in record stand-by mode lets you record music separately for the left and right hand. If music was recorded in this manner, you can listen to either part individually during playback. (See page 25 for details on "Playing Back Music Separately for the Left and Right Hand".)

● How to record music separately for the left and right hand

① Confirm that the Disklavier is in record stand-by mode.

Pressing the Rec. button enters record stand-by mode.

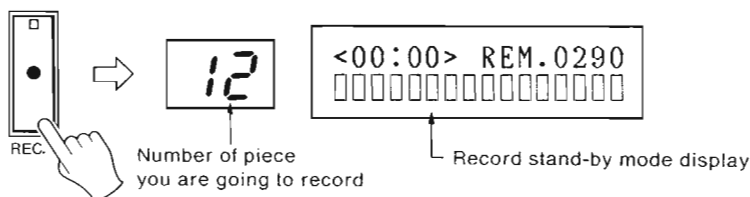

② Enter split point input mode.

Press the Rec. button twice to enter split point input mode.

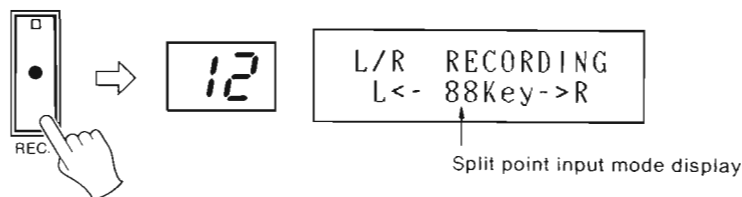

③ Designate the split point.

Hit a key on the keyboard to designate the desired split point. It is usually best to hit the key furthest on the right in the left hand part, thus designating it as the split point.

The designated split point is indicated on the LCD as a key number as shown in the illustration on the right.

For example, designating middle C (key number 40) as the split point calls up the following display.

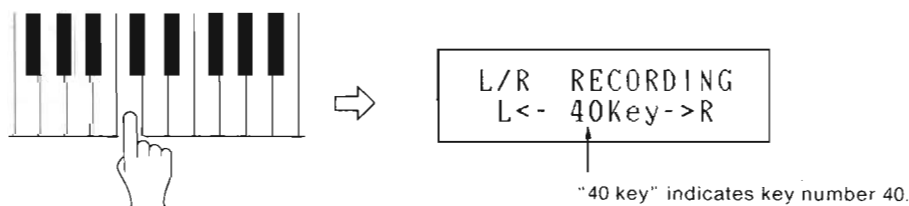

④ Start recording.

Pressing the Start/Pause button starts recording.

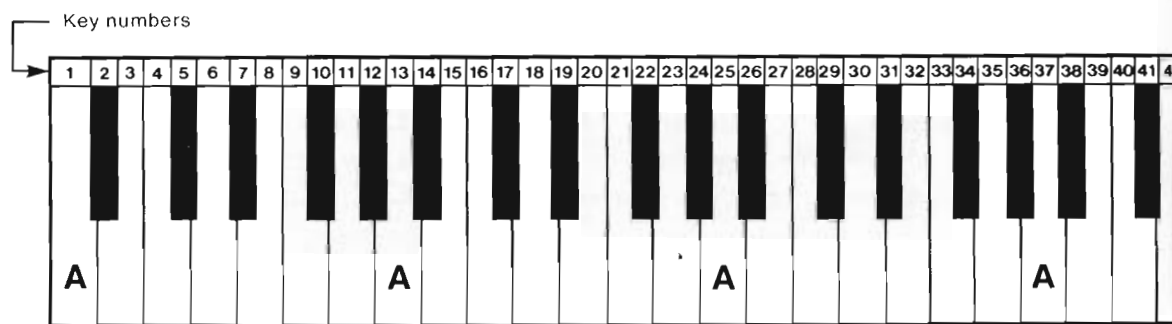

Recording with the Metronome

If the metronome function is turned on during record stand-by mode, you can confirm the correct tempo with your ears and eyes - a practical aid for a perfect recording.

① **Confirm that the Disklavier is in record stand-by mode.**

② **Turn on the metronome function.**

Press the Metronome button to turn on the metronome function.

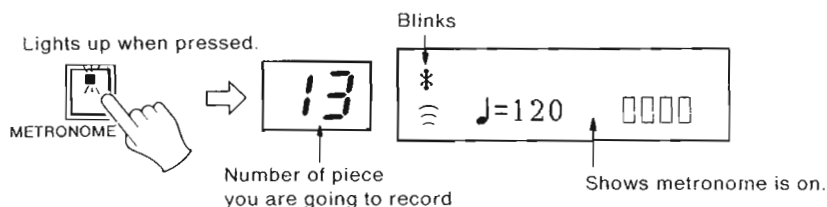

③ **Setting the metronome**

● **Turning the metronome sound on and off.**

Pressing the “-” button after having pressed the Volume button turns off the metronome’s sound. Pressing the “+” button instead turns it back on again. (Remote control is not possible.)

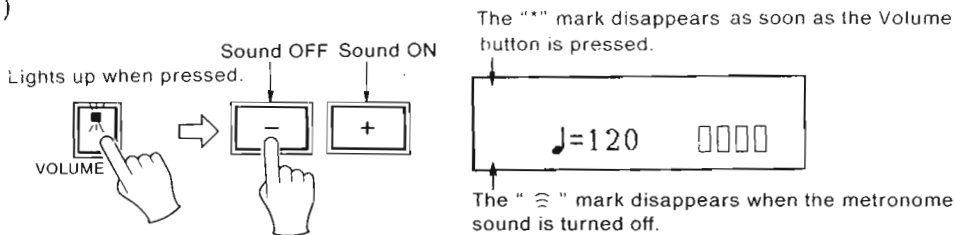

● **Metronome tempo setting**

Pressing the Tempo button allows you to set the metronome tempo with the “-” and “+” buttons. (Remote control is not possible.)

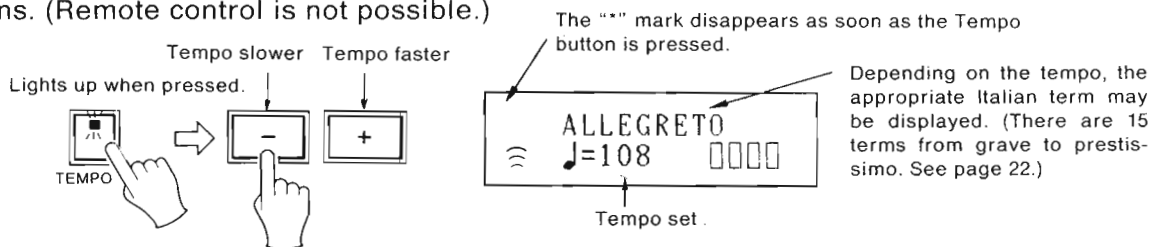

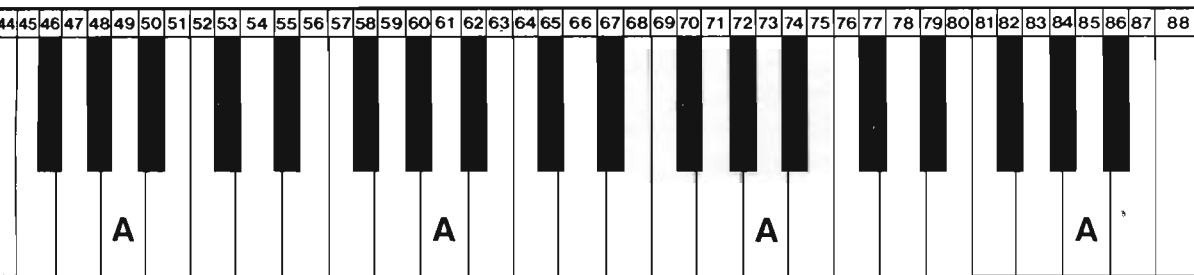

★ When you wish to alter the tempo significantly, press the Tempo button again to make the “*” mark flash. You can now change the tempo over a wide range using the “+” and “-” buttons.

Tempo can be adjusted with the range from ♩ = 40 to ♩ = 230.

● **Setting the metronome time**

Pressing the Trans/Beat button allows you to set the metronome time with the “-” and “+” buttons. Time is indicated in figures marked(Remote control is not possible.)

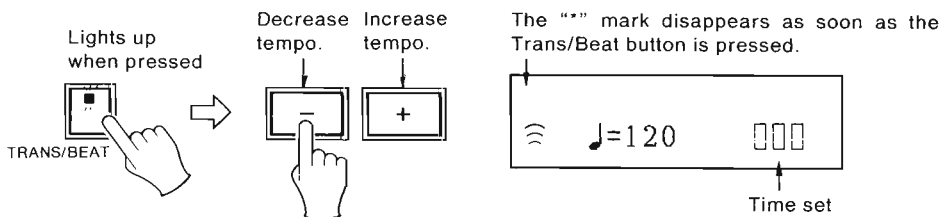

Time can be set to one-, two-, three-, four- or six-part time.

④ **Starting to record**

Pressing the Start/Pause button allows you to commence recording whenever you want.

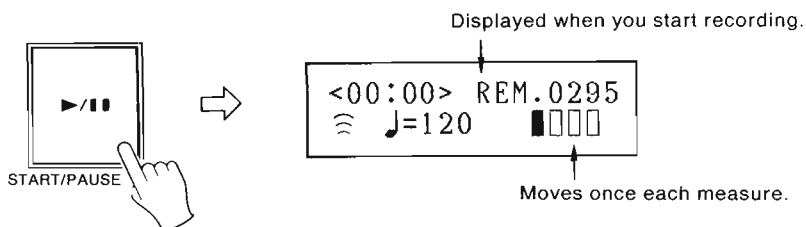

★ The metronome sound has an accent on the first beat of each measure. For example, the metronome will sound as follows in four-four (common time).



★ There is no need to worry that the metronome sound will be recorded.

- ★ The list below shows the Italian expressions corresponding to various speeds.
(These expressions are also used to designate the metronome tempo.)

Tempo	Italian terminology
♩ = 40	GRAVE
46	LARGO
52	LENTO
56	ADAGIO
60	LARGHETTO
69	ANDANTE
80	ANDANTINO
92	MODERATO
108	ALLEGRETTO
132	ALLEGRO
144	ALLEGRO ASSAI
152	ALLEGRO VIVACE
160	VIVACE
184	PRESTO
208	PRESTISSIMO

Rerecording

When you want to delete a recorded piece and record something else in its place, using the same music number, specify the desired music number in record stand-by mode.

- ① **Check whether the Disklavier is in record stand-by mode.**

- ② **Specify the music number of the piece you wish to rerecord.**

Press the appropriate FF button to call up the music number of the piece you want to rerecord on the music number display. (When using the remote control unit, use the Tune Select buttons.)

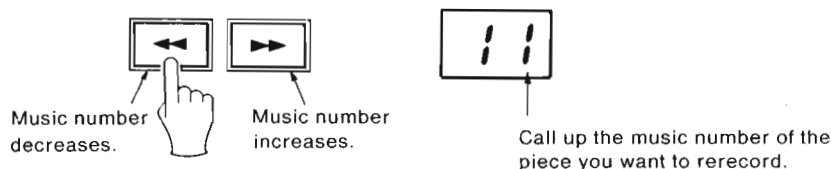

- ③ **Start recording.**

Press the Start/Pause button to start recording.



Recording Ensemble Music

When recording ensemble pieces, use MIDI recorders such as the Yamaha YRM-301 (MSX). See section 3-7 in the MIDI Handbook about compatibility.

Playback Functions

The following section introduces various functions concerning playback.

Return • FF

In stop mode, the Tune Select/Return•FF buttons allow you to designate the music number. During playback, however, these buttons function as Fast Forward and Return buttons. When you wish to move to a later part of the recording with fast forward, press the  button. Should you wish to move to a previous part of the recording with rewind, press the  button. The indication of elapsed time on the LCD will change in accordance with the fast forward or rewind operation. When the desired point is reached, press the respective button again. Playback will start from there.

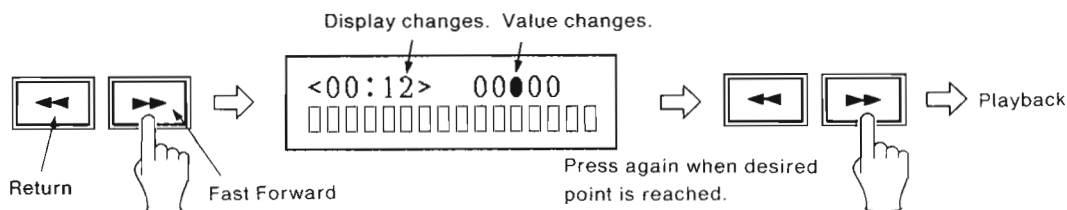

★ Since the remote control unit has special FF and Return buttons, fast forward and rewind are both possible during stop mode as well.

Playback Pause

Pressing the Start/Pause button during playback enters playback pause mode, stopping playback until you press the Start/Pause button again to restart it.

Altering the Tempo

Tempo can be altered during playback. To do so, press the Tempo button in stop mode or during playback, then change the tempo with the “-” or “+” button.

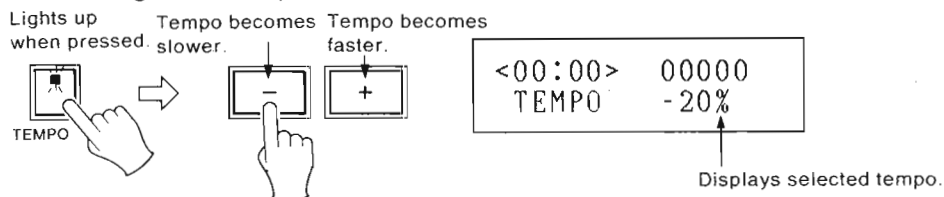

★ Tempo values can be selected from among -50%, -40%, -30%, -20%, -10%, -05%, 00%, +05%, +10% and +20%. 00% indicates normal tempo, i.e. the tempo with which the piece was recorded.

Transposition

You can transpose the key of a piece for playback. In stop mode or during playback, press the Trans/Beat, then use the “-” or “+” button to transpose the key.

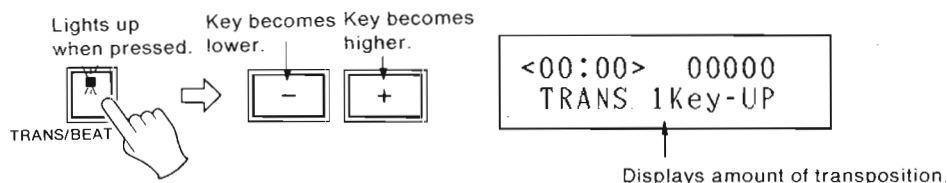

★ Pieces can be transposed in the range from 2oct-down to 2oct-up. “Normal” indicates the key in which the music was recorded, i.e. there is no transposition.

Repeat Playback

When you want to listen repeatedly to all of the music on one floppy disk, or when you want to repeat a single piece or just one part between two designated points, use the practical repeat function. Once the repeat function has been selected, the music is performed repeatedly until repeat is turned off.

• Repeating all music on a disk

Pressing the All Repeat button in stop mode or during playback causes all pieces on the present disk to be repeated until stopped.

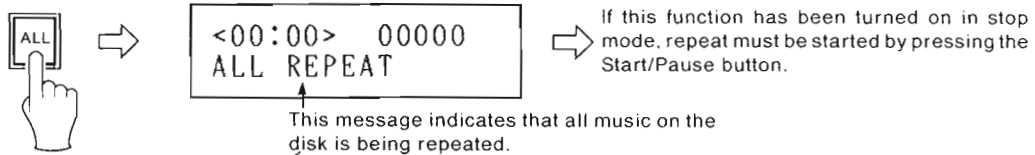

In order to turn off the repeat function, press the All Repeat button once again.

• Repeating single pieces

Pressing the Repeat button in stop mode or during playback causes the piece with the currently selected music number to be repeated until stopped.

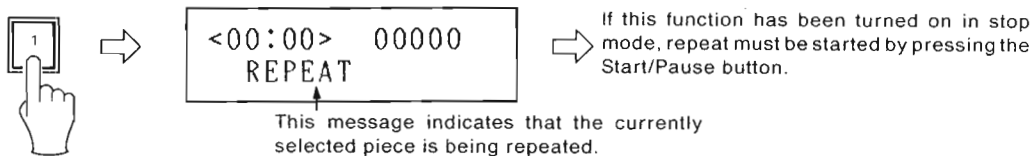

In order to turn off the repeat function, press the Repeat button once again.

• A-B Repeat

A-B repeat means that the part in a piece of music between the two designated points A and B will be repeated. This function can be set as follows.

① Playback the desired piece.

② Designate point A.

When playback reaches the point from which you wish to start repeating, press the A-B Repeat button.

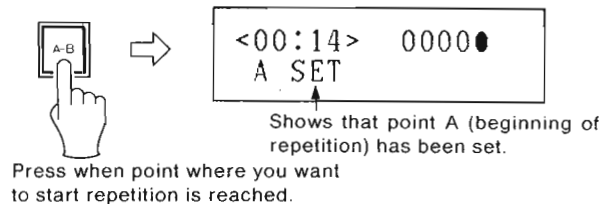

③ Designate point B.

When playback reaches the point where you want the repetition to end, press the A-B Repeat button again.

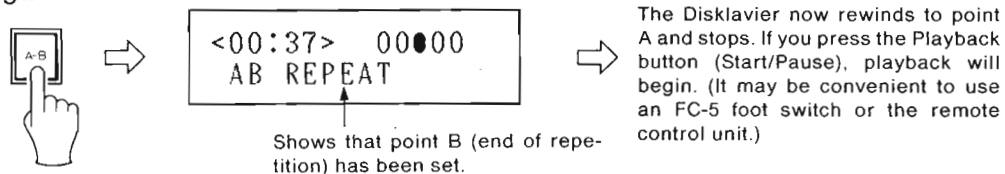

④ Canceling the repeat function

In order to cancel the repeat function, press the A-B Repeat button once again.

★ A-B Repeat cannot be used between points not set in the same piece of music.

Return and Stop

By designating only point A with A-B repeat, it becomes possible to use the Return and Stop function. The Return and Stop function, which is started by pressing the  button, rewinds to point A and stops there.

• Example for Return and Stop

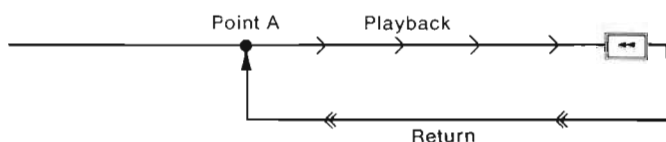

Pressing the Return button returns to point A and stops there.

Playing Back Music Separately for the Left and Right Hand

When playing back music that has been recorded separately for the left and right hand, it is possible to use the Part Cancel function. This function allows you to cut the sound of the left or right hand part during playback. In order to use this function, follow the steps below.

① Select a piece of music that has been recorded separately for the left and right hand.

② Press the Stop button.

When the Stop button is pressed, the following display appears on the LCD for about 10 seconds.

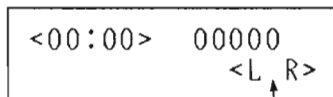

Shows that the piece has been recorded separately for the left and right hand.

③ Set the Part Cancel function.

If you want to cut playback of the left-hand part, press Part Cancel button L.

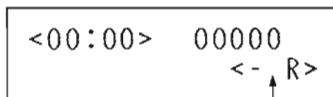
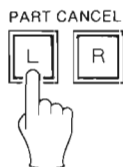

Shows the left-hand part is canceled.

If you want to cut playback of the right-hand part, press Part Cancel button R.

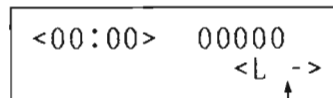
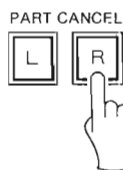

Shows the right-hand part is canceled.

④ Start playback.

Pressing the Start/Pause button starts playback.

- ★ When canceling this function, press this button once more.
- ★ This function is particularly suited to practice since you can have the Disklavier play back the part of one hand and play the other part yourself.
- ★ Using this function together with connected MIDI keyboards or MIDI tone generators allows even more sophisticated applications.

Playing Back Ensemble Music

When playing back ensemble pieces that have been recorded with a MIDI recorder such as the YRM-301, you can choose which part you want played back by following the steps below.

● **How to designate a part**

This shows you how to specify the part to be played back on your piano.

① **Select the ensemble piece you want to play back.**

② **Press the Stop button.**

Pressing the Stop button calls up the following display on the LCD for about 10 seconds.

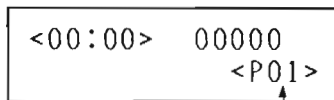

Displayed only when ensemble piece selected.

③ **Designate the part.**

Use the Part Cancel button to designate the part you want to have played back on the piano.

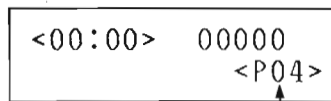
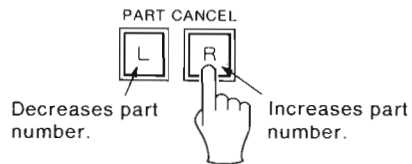

Display the desired part number.

④ **Start playback.**

Press the Start/Pause button. The designated part will be played back on the piano.

* See sections 3-6 and 3-7 in the MIDI Handbook.

Additional Functions

The following section introduces additional functions which have nothing to do with recording or playback.

Input of Music and Disk Titles

Follow the instructions below when you want to input the title of a piece of music or an entire floppy disk. The same procedure can be used to change music or disk titles previously input. The disk title is always displayed for about 10 seconds after a disk has been inserted.

• Music Title Input

① **Enter record stand-by mode.**

Press the Rec. button to enter record stand-by mode.

② **Press the Rec. button again.**

Pressing the Rec. button again allows you to input a music title.

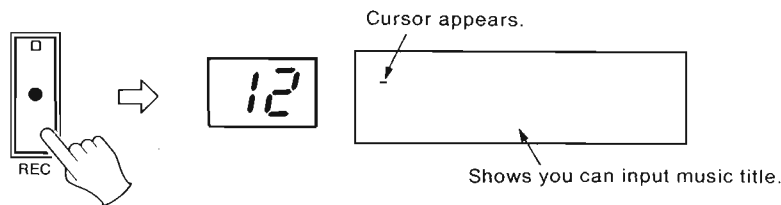

③ **Display the desired music number.**

Use the Tune Select/Return·FF buttons to call up the music number of the piece whose title you wish to input. (When doing this with the remote control, use the Tune Select buttons.)

④ **Input the music title.**

Use the piano keyboard, the loud pedal and soft pedal to input the music title. Which key corresponds to which symbol is shown in the illustration on the next page along with the pedal functions. Input of up to 32 symbols is possible.

If for example you want to input "Prelude 1", proceed as follows.

(1) Press key 53 to display a capital "P", then push down the loud pedal to input this character.



(2) Next, input a small "r".

Press the soft pedal to activate the lowercase mode, and again press key 55 corresponding to "r".



(3) In the same manner, press key 42 to display a small "e" and push down the loud pedal for input.

(4) Finally input the remaining characters "l", "u" "d" and "e" in the same way.

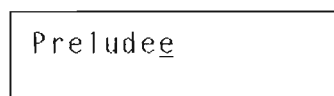

Function of Keys and Pedals for Title Input

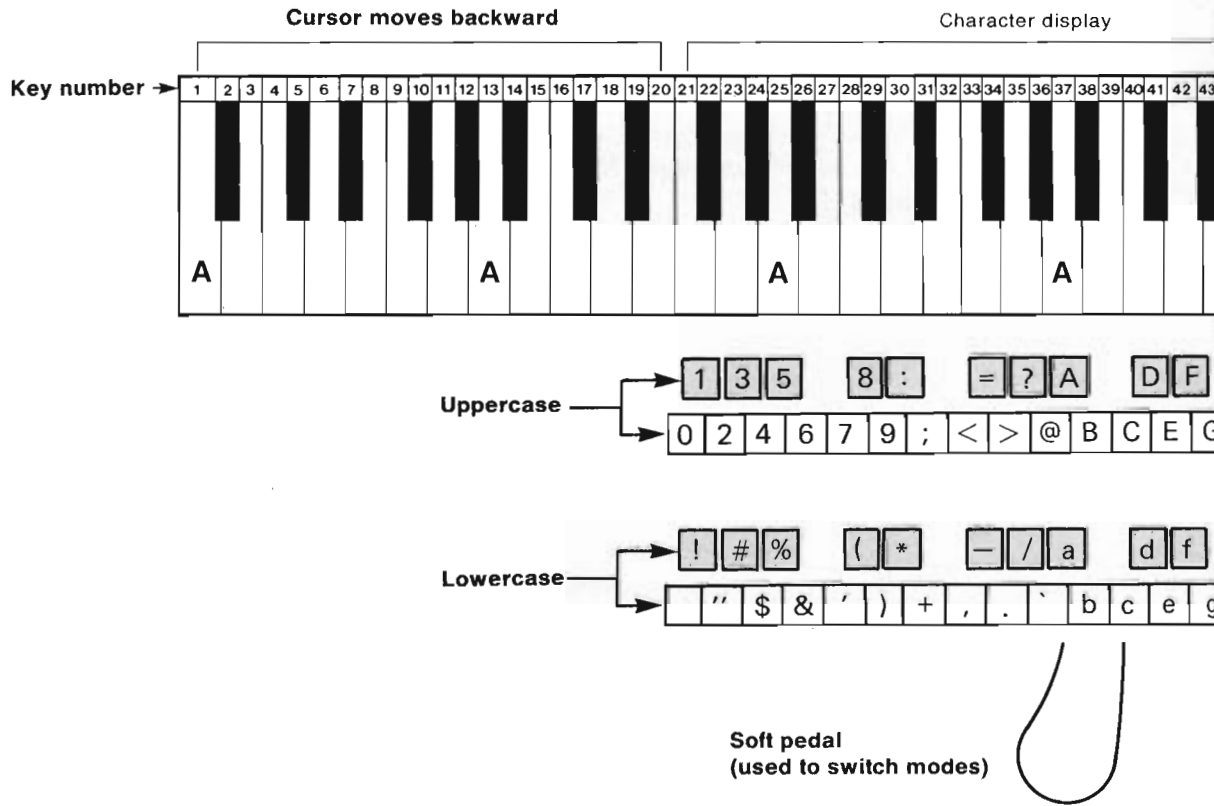

(5) Now enter a space to go between the "e" of "Prelude" and "1".
To do so, press the soft pedal to activate the lowercase mode, and press key number 21 and push down the loud pedal. A space will be input.

(6) Input "1".
Press key number 22 and push down the loud pedal.

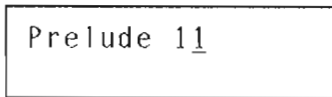

⑤ **Complete input.**
Press the Stop button to complete input.

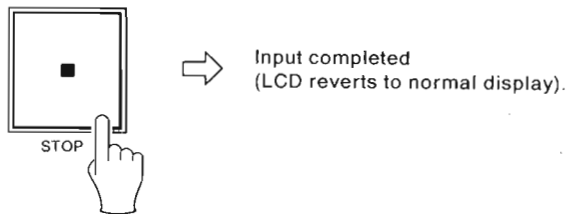

Cursor moves forward

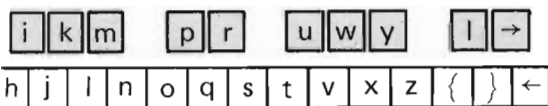
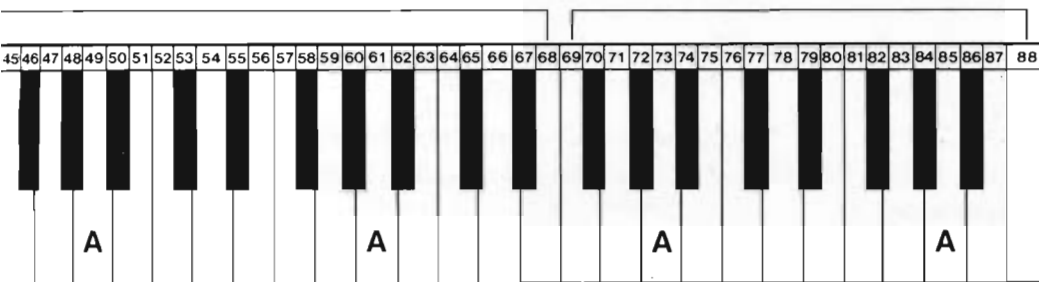

Loud pedal
(used to input characters)

● Disk Title Input

① Enter record stand-by mode.

Press the Rec. button to enter record stand-by mode.

② Press the Rec. button again.

Press the Rec. button again. You could now input a music title.

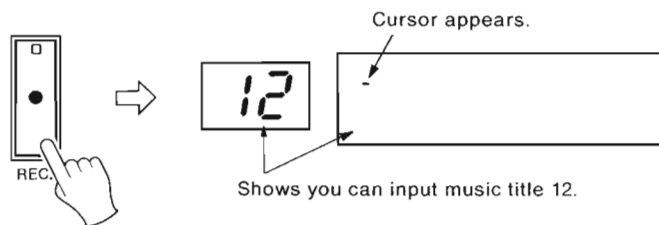

③ Keep the  button depressed.

Keep the Tune Select/Return·FF  button depressed. Since the disk title is input before the first music title, continue pressing this button while the music number display shows increasingly lower numbers (...03, 02, 01) until this display finally goes blank. (When using the remote control unit, press the reverse Tune Select button.)

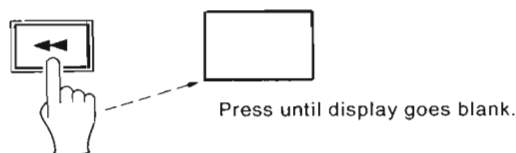

④ **Input the disk title.**

Using the same method as described for music title input, enter the desired disk title. You can use up to 64 characters.

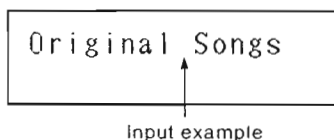

⑤ **Complete input.**

Press the Stop button to complete input.

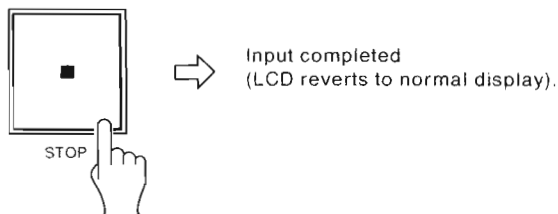

Using the Metronome Function Alone

The metronome function can be used not only during recording, but whenever you want to practice the piano. Follow the instructions below to turn it on.

① **Enter stop mode.**

Press the Stop button to enter stop mode.

② **Turn on the metronome function.**

Press the Metronome button to turn on the metronome function.

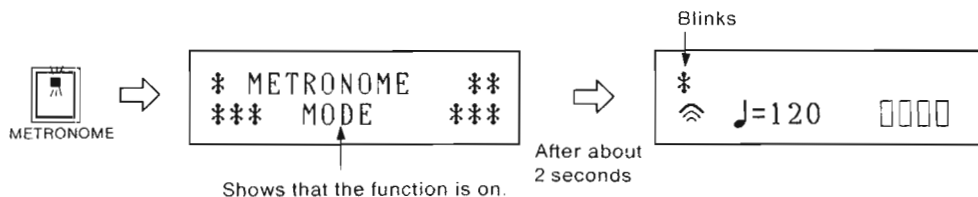

③ **Metronome setting**

Following the steps described on page 20 under "Recording with the Metronome", you can turn the metronome sound on or off and set the tempo and time.

④ **Start the metronome.**

Press the Start/Pause button to start the metronome. (Remote control is not possible.)

★ When you want to stop the metronome, press the Stop button. (Remote control is not possible.)

★ In order to switch off the metronome function, press the Metronome button once again.

Deleting Single Pieces of Music

When you want to delete a recorded piece of music, carry out the following steps. Please note, however, that both the music number and music title of the deleted piece will remain.

① **Enter record stand-by mode.**

Press the Rec. button to enter record stand-by mode.

② **Select the piece of music you wish to delete.**

Press the Tune Select/Return·FF button to call up the number of the piece of music you wish to delete on the music number display. (When using the remote control unit, use the Tune Select buttons.)

③ **Delete**

Press the Start/Pause button. You will hear a beeping sound. When the time display on the LCD starts counting, press the Stop button. This completes deletion of the selected piece.

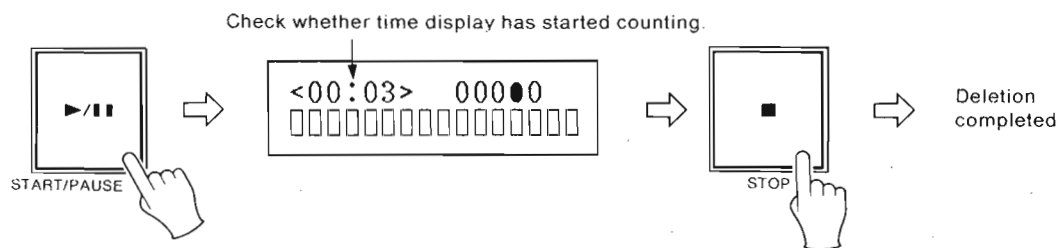

MIDI Functions

Making use of MIDI functions greatly expands the Disklavier's range of applications. All available MIDI functions are introduced in detail in the supplied MIDI Handbook, and we advise you to read them carefully.

Specifications

Design

Control unit	<ul style="list-style-type: none">• Key switches• LCD• LED indicators• LED display• Disk drive• Jacks• Media	18 Dot matrix (16 characters x 2 lines) Power, Record, Volume, Tempo, Transposition, Metronome, MIDI. 7 segments x 2 digits 3.5 inch micro-floppy disk drive MIDI IN/OUT, foot switch phone jack Double sided, double density, double track 3.5 inch microfloppy disks Memory capacity: 628 kbytes Number of pieces: 60 Music titles: 32 characters Disk titles: 64 characters
Solenoid unit	<ul style="list-style-type: none">• Polyphonic voices	16
Sensor unit	<ul style="list-style-type: none">• Polyphonic voices	16

Power supply

<ul style="list-style-type: none">• Power requirement• Ambient temperature	Local AC voltage 4°C ~ 40°C
---	--------------------------------

Standard equipment

- Wireless remote control unit
- Prerecorded floppy disk
- Blank floppy disk

* Specifications and exterior design are subject to change without notice.

Warning Displays and Error Messages

This Disklavier will display warnings and error messages on its LCD when operation has been incorrect or other problems have arisen. Should this happen, please take the appropriate measures after having found out what the trouble is by referring to the table below. Please note that some of these problems are easy to mistake for malfunctions though they are actually very easy to solve by yourself.

Display	Cause	What to do...
DISK NOT READY!	Always displayed when power turned on.	
DISK WRITE PROTECTED!	Floppy disk contents are protected.	When recording or entering a music or disk title, cancel the disk's memory protect function by sliding back the erasure protection tab.
UNFORMATTED DISK	Unformatted disk has been inserted.	When you want to record on a new disk, you must first format it.
CONVERT DISK!	Disk that has been used with other system has been inserted.	In order to use a disk that was previously used with another system, it must be converted.
ERROR OCCURRED!! (PUSH STOP KEY)	Disk defective.	Replace the disk.
	Hardware problem.	Press the Stop key to cancel the error message. If this message appears frequently, contact your dealer or a service center.
MIDI DATA ERROR! (PUSH STOP KEY!)	MIDI data faulty.	Press the Stop key.
	Too large a volume of MIDI data received at once.	Press the Stop key.
	MIDI connections faulty.	After turning off the power for both pieces of equipment, check the connections.
FILE NOT FOUND! RE-CONVERT DISK!	Error occurred during playback or recording.	Reconvert, then rerecord.
	During rerecording, the disk's memory capacity has been exceeded.	Reconvert and record on a different disk.
CANNOT FORMAT!	Disk defective.	Replace the disk.
DISK FULL!	Disk full to capacity.	Record on a different disk.
CANNOT CONVERT!	Disk defective.	Replace the disk.
THIS FILE IS PROTECTED!	A purchased disk contains a piece of music which cannot be rerecorded.	
EXECUTING!	This message appears whenever internal processes take some time during which external operation is not possible. Please do not remove the disk as long as this message is displayed.	
CANNOT RECORD MORE SONGS	Attempt was made to record a 61st piece of music on a disk.	The maximum number of pieces that can be recorded on a single disk is 60.
PUSH STOP KEY	The unit was not operated for 5 minutes.	Press the Stop key.

Troubleshooting

Whenever you have trouble operating the Disklavier, please refer to the table below. If you are still not able to solve the problem or if a malfunction not listed in the following occurs, turn off the power, unplug the power cord and contact your dealer or the nearest Yamaha service center.

Problem	Cause	What to do...
No power.	The power cord or the connection cable has not been connected properly.	Plug in firmly.
Recording not possible.	The power cord or the connection cable has not been connected properly.	Plug in firmly.
	Mistaken operation was attempted.	See previous section on "Warning Displays and Error Messages".
Playback not possible.	The power cord or the connection cable has not been connected properly.	Plug in firmly.
	Mistaken operation was attempted.	See previous section on "Warning Displays and Error Messages".
	Attempt was made to play back a piece of music that has already been deleted.	
	Recording was not carried out because recording operation was mistakenly interrupted.	Rerecord.
Playback is repeated over and over again.	The repeat function is on.	Cancel the repeat function.
Playback is performed at a different volume, a different tempo or a different pitch than the original recording.		Reset the settings for volume, tempo and transposition to "normal".
A note that should not be played is reproduced.	Your fingers slipped during recording.	Rerecord the piece, playing more precisely.
A grating sound is heard from the piano during playback.	Due to the Disklavier's design, the solenoid drive unit internally pushes up the lower rear part of the piano's keys. If the playback volume is too low, the sound of the drive unit touching the back part of the keys may become audible.	
Certain notes are not played back at all.	In pieces containing triplets, trills or other fast passages, the keys are sometimes hit repeatedly before they have been able to return to their original position. In such cases, certain notes may not be reproduced during playback.	
	The tempo setting is too fast.	Reduce the tempo.
	The volume is set too low.	Raise the volume.
	The touch of the performance during recording was too weak.	Rerecord the piece, playing more precisely.
The accentuation during playback is different than the one recorded.	The touch of the performance during recording was too weak.	Rerecord the piece, playing more precisely.

FCC INFORMATION

While the following statements are provided to comply with FCC Regulations in the United States, the corrective measures listed below are applicable worldwide.

This series of Yamaha music equipment uses frequencies that appear in the radio frequency range and if installed in the immediate proximity of some types of audio or video devices (within three meters), interference may occur. This series of Yamaha equipment have been type tested and found to comply with the specifications set for a class B computing device in accordance with those specifications listed in subpart J of part 15 of the FCC rules. These rules are designed to provide a reasonable measure of protection against such interference. However, this does not guarantee that interference will not occur. If your music equipment should be suspected of causing interference with other electronic devices, verification can be made by turning your music equipment off and on. If the interference continues when your equipment is off, the equipment is not the source of interference. If your equipment does appear to be the source of the interference, you should try to correct the situation by using one or more of the following measures:

Relocate either the equipment or the electronic device that is being affected by the interference. Utilize power outlets for the music equipment and the device being affected that are on different branch (circuit breaker or fuse) circuits, or install AC line filters.

In the case of radio or TV interference, relocate the antenna or, if the antenna lead-in is 300 ohm ribbon lead, change the lead-in to the co-axial type cable.

If these corrective measures do not produce satisfactory results, please contact your authorized Yamaha products dealer for suggestions and/or corrective measures.

If you cannot locate a franchised Yamaha products dealer in your general area contact the products Service Department, Yamaha Music Corporation, 6600 Orangethorpe Ave., Buena Park, CA 90620, U.S.A.

If for any reason, you should need additional information relating to radio or TV interference, you may find a booklet prepared by the Federal Communications Commission helpful:

"How to Identify and Resolve Radio -- TV Interference Problems". This booklet is available from the U.S. Government Printing Office, Washington D.C. 20402 -- Stock No. 004-000-00345-4.

MEMO

1871

YAMAHA

YAMAHA

disklavier

MX-100A

MIDI Hand Book

CONTENTS

1. What Is MIDI?	2
2. MIDI Terminals of the Disklavier	2
3. MIDI Control	3
3-1. Reproducing Sound from Ordinary Music through an External Sound Source	3
3-2. Playing Back Music Separately for Left and Right Hand	5
3-3. Producing Sound from an External Sound Source During Performance.....	6
3-4. Using the Disklavier when Playing Back from a Sequencer	12
3-5. Storing Piano Performance Content in the Sequencer	14
3-6. Playback of Ensemble Music	15
3-7. Data Compatibility.....	16
3-8. Starting and Stopping the Rhythm Machine/Sequencer.....	17
4. MIDI Data Format.....	18
5. MIDI Troubleshooting and Know-how	23
6. Block Diagram	25

1. What Is MIDI?

MIDI is the abbreviation for “Musical Instrument Digital Interface”. Literally translated, it could be described as “digital coupling of musical instruments” or “digital communication between musical instruments”. What it means is, if different musical instruments are connected to each other, they can be made to produce sound at the same time, or memorized pieces can be exchanged between them. As a world- standard system, MIDI provides a common standard between instruments of different companies, so that whether a product has already been produced and marketed by another company, or whether it is just now in the process of being marketed, it can be made compatible and used with other instruments through the MIDI standard.

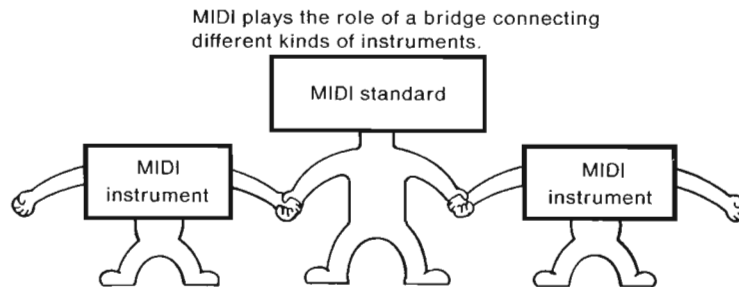

2. MIDI Terminals of the Disklavier

Please take a look at the lower right corner on the front. There are 2 MIDI terminals, called MIDI OUT and MIDI IN.

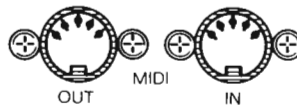

These terminals are used for connecting another MIDI instrument to the Disklavier. Simply described, they operate in the following way:

- **MIDI OUT**

This terminal is used when you are playing the piano and you want to send the piano performance and/or playback contents to a MIDI keyboard or MIDI tone generator at the same time that you are playing. It is also used to record sound and information on another MIDI instrument, such as a MIDI sequencer or a MIDI recorder. By using this terminal, you can start and stop the MIDI rhythm machine and other functions, using a button on the Disklavier.

- **MIDI IN**

This terminal is used to receive material recorded on a MIDI sequencer or MIDI recorder back into the Disklavier, for piano playback.

★ When connecting MIDI units, please use the MIDI cables sold separately.

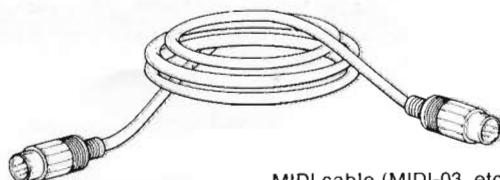

MIDI cable (MIDI-03, etc.)

3. MIDI Control

When MIDI is connected, various kinds of control become possible. These will be explained in this section. (Please use this handbook in conjunction with the user's manuals of the instruments you are connecting.)

3-1. Sound Generation of an External Source while Reproducing Ordinary Music through an External Sound Source

When a MIDI sound source instrument (keyboard, tone generator, etc.) is connected to the MIDI OUT terminal of the Disklavier, the sound of the piano can be reproduced simultaneously with the voice of another instrument when playing ordinary music. When the voices of the two instruments are produced with the same timing, the sound is extremely thick and rich.

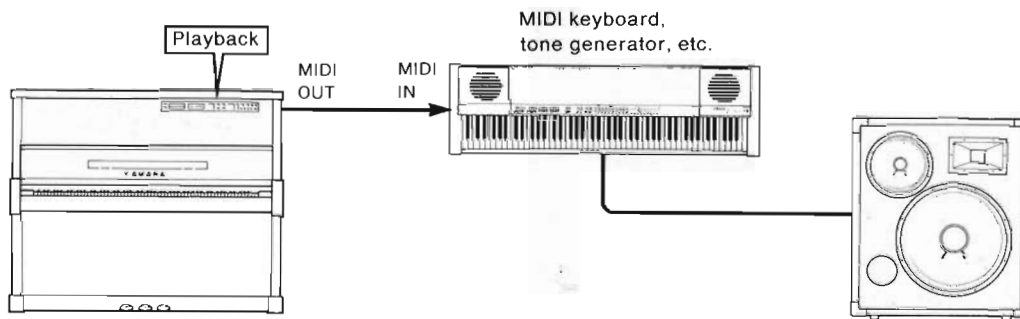

If you connect another instrument to the MIDI THRU terminal of a connected instrument, the voices of all three instruments can be played back at once.

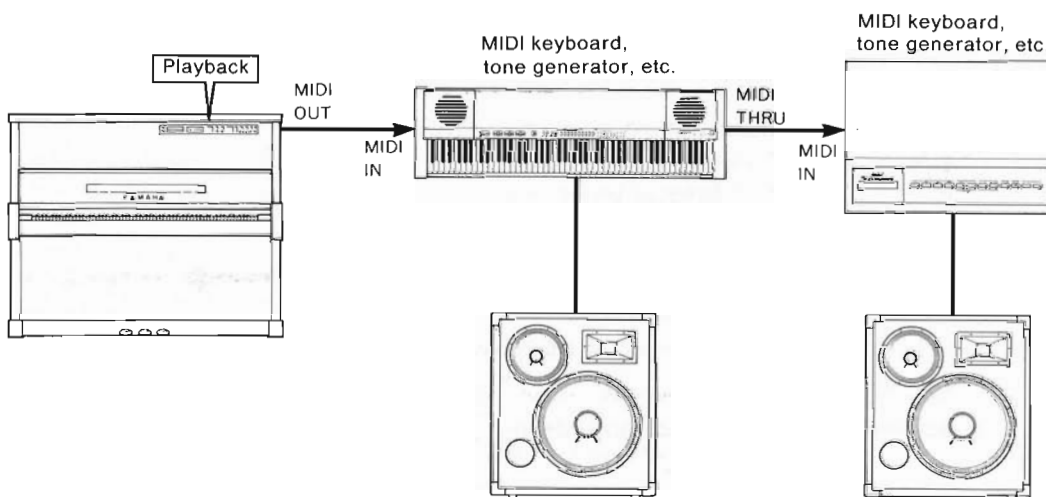

What Is MIDI THRU?

Your Disklavier does not have a MIDI THRU terminal, but some MIDI instruments, such as the MIDI keyboard, are provided with this terminal. The MIDI THRU terminal receives information from the MIDI IN terminal and outputs it without changing it in any way. Using the MIDI THRU terminal, it is possible to connect a variety of instruments.

OPERATION PROCEDURE

① Connections

Make connections as shown on the lefthand page.

② Preparation for playback

After turning on the power switch, insert a floppy disk.

③ Set the MIDI reception channel of the external instrument to 1.

At the time of playback, performance information is sent through the MIDI OUT terminal of the Disklavier using MIDI channel 1. In order for the connected equipment to be able to receive the information, its reception channel must be set to 1.

④ Select the voicing of the external instrument

Select the voicing that you want to be simultaneously reproduced.

⑤ Starting playback

When the Start/Pause button of the Disklavier is pressed, performance begins.

⑥ Adjusting the volume balance

Adjust the balance between the piano volume and the volume of the external instrument.

★ If the playback tempo is changed, the tempo of the external instrument is also changed. However, if the volume of the piano is changed, or if transposition occurs, these changes are not reflected in the external instrument.

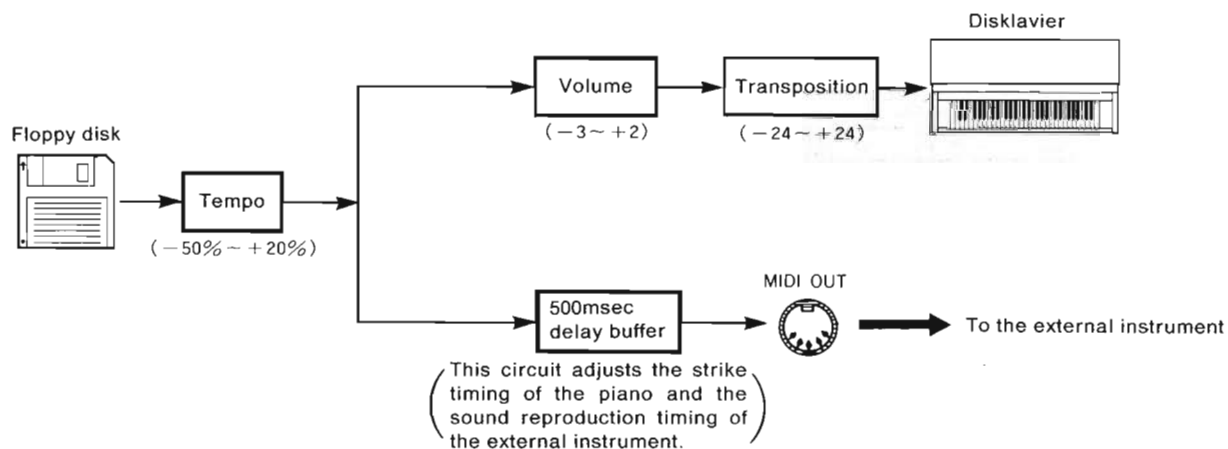

What Is a MIDI Channel?

With MIDI, sometimes various kinds of information are transmitted through the cable at the same time. For example, when an ensemble piece is being played back, information concerning various parts is being output through MIDI OUT at the same time, and sent to the external instrument.

With MIDI, so that the receiving instrument need receive only the information necessary at the time, information is sent with a given channel number. (This is the MIDI channel.) With this system, only information which is necessary at the time will be received. Unnecessary information is differentiated and is not received by the external instrument at the same time.

MIDI channels range from channel 1 to channel 16.

With the Disklavier, if the channel number is not changed by the user, ordinary music is output on channel 1. For music divided for left and right hand, the lefthand part is output through channel 1 and the righthand part through channel 2. For ensemble music, each part is output through a different channel.

3-2. Playing Back Music Separately for Left and Right Hand

For music divided for left and right hand, the lefthand part is output through channel 1 and the righthand part through channel 2. If an instrument that will be the sound source is connected to the MIDI OUT terminal, the lefthand and righthand parts can be played back with different voices.

- **If one instrument is connected** one part is played back with the piano sound, and the other part with the sound of the external instrument.

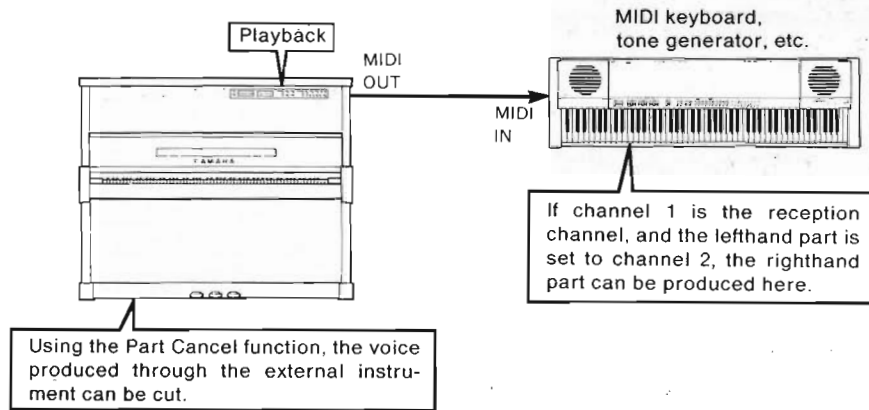

- **If two instruments are connected** both parts can be played back using only the voice of the external instrument.

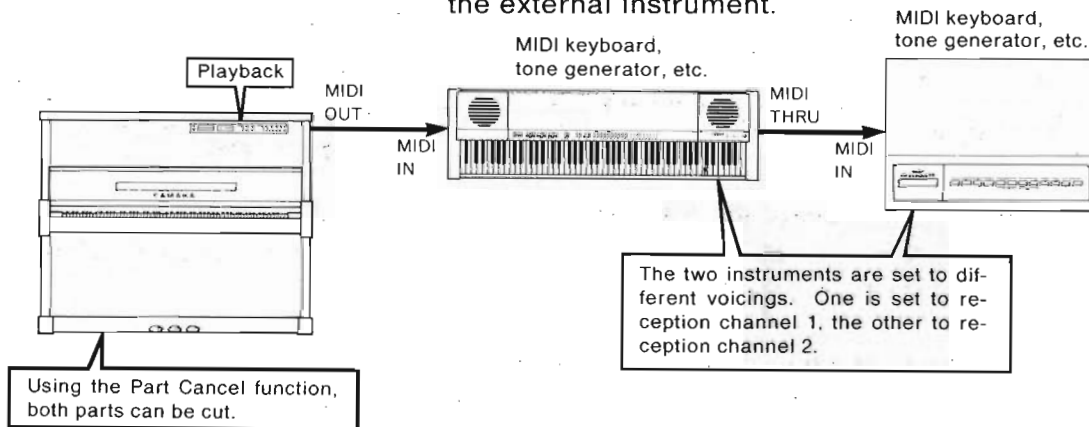

- ★ If the playback tempo is changed, the tempo of the external instrument also changes. However, if the volume is changed or transposition occurs, these changes are not reflected in the external instrument.

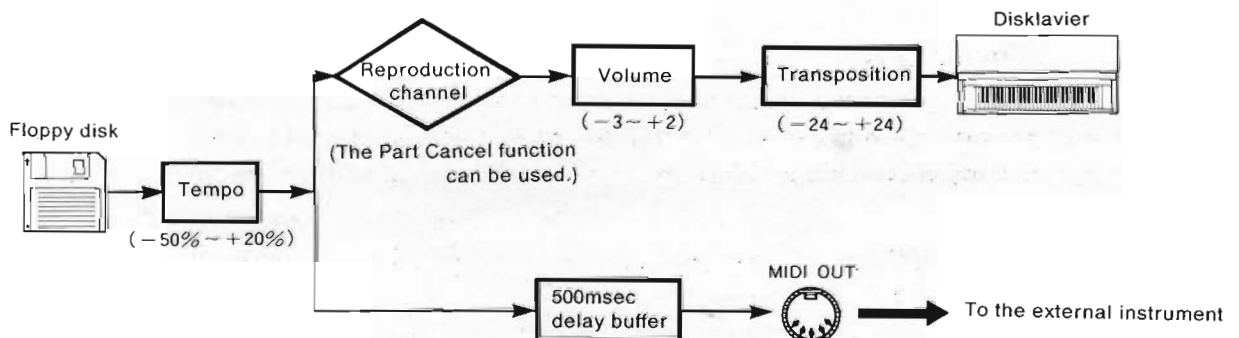

3-3. Producing Sound from an External Sound Source During Performance

In what is called "MIDI Setup Mode", a "DELAY OUT/KEYBOARD OUT Switch" is available. Setting this to KEYBOARD OUT causes sound to be produced from an external sound source during performance.

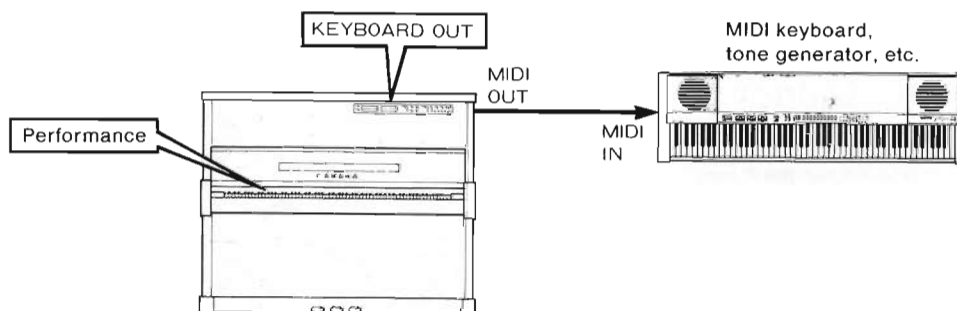

What Is MIDI Setup Mode?

MIDI Setup Mode is a mode that lets you specify conditions for MIDI transmission and reception during MIDI control. For MIDI Setup Mode, suspend disk operation and press the MIDI button. The display changes to the MIDI Setup Mode display.

This lights when pressed.

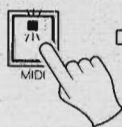

```
** MIDI SETUP **  
*** MODE ***
```

This shows that you are in MIDI Setup Mode.

After about 2 seconds

```
MIDIOUT=DELAYOUT  
MIDI IN VOL.= 00
```

This shows the MIDI Setup Mode display.

What the Various Buttons Do in MIDI Setup Mode

In MIDI Setup Mode, the function of each button changes as shown on the following page.

- * In MIDI Setup Mode, ordinary operations such as playback and storing cannot be performed. Remote control operations are not possible, either.
- * To resume normal operations, press the MIDI button once again. MIDI Setup Mode is cancelled. However, any conditions that you set while in MIDI Setup Mode are maintained as long as the power is not turned off.

The functions used in MIDI Setup Mode are still possible even when you are performing the control operations introduced in sections 3-1 and 3-2. The functions that can be used are explained below.

- The voicing of the external instrument can be changed at the Disklavier.
 - The volume of the external instrument can be lowered at the Disklavier.
 - If you change to KEYBOARD OUT, a split can be output, or trans position can be performed on the external instrument only, or the transmission channel can be changed.
 - Reception channel changes, and settings for volume and transposition.
- * Please cancel MIDI Setup Mode before you begin playback.

- **MIDI OUT setting**

This is used when setting values for MIDI transmission or reception.

- **TRANS**

This is used for transposition on only the instrument connected to the MIDI OUT terminal.

- **MIDI IN Setting**

This is used for playback and for setting values for MIDI reception.

- **SPLIT**

This is used when outputting a split.

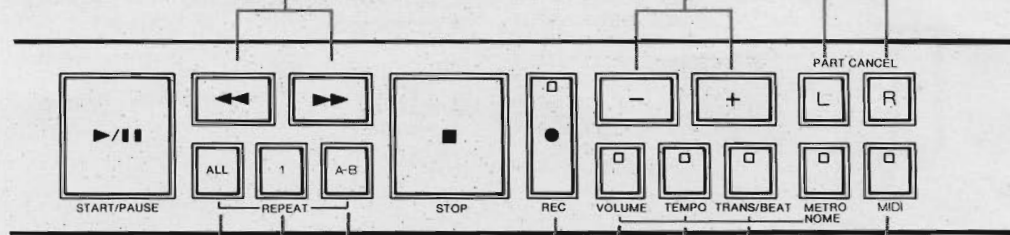

- **MIDI OUT PRG.**

This is used when changing the voice number of an instrument connected to the MIDI OUT terminal.

- **MIDI SETUP**

This is used to call MIDI Setup Mode. When it is pressed once again, normal conditions are resumed.

- **MIDI OUT CH.**

This is used to change the MIDI transmission channel.

- **MIDI IN TRANS**

This is used when transposing during playback or MIDI reception.

- **MIDI OUT VOL.**

This is used to change the volume of an instrument connected to the MIDI OUT terminal.

- **MIDI IN CH.**

This is used when changing the MIDI reception channel (the channel for piano performance).

- **MIDI IN VOL.**

This is used when changing the volume during playback or MIDI reception.

- **DELAY OUT/KEYBOARD OUT Switch**

This is used to direct the output of this unit to KEYBOARD OUT. If it is pressed once again, the system returns to DELAY OUT.

OPERATION PROCEDURES

① Preparation

When all connections have been finished, turn on the power and insert a floppy disk.

② Switching to MIDI Setup Mode

Press the MIDI button to enter MIDI Setup Mode.

③ Switching to KEYBOARD OUT

Press the Record button to switch to KEYBOARD OUT. (If you press it once again, you will return to DELAY OUT.)

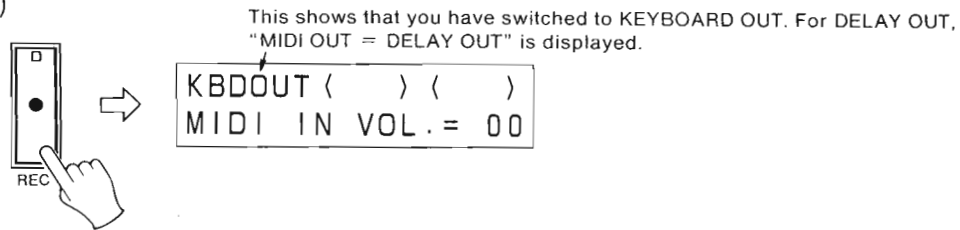

④ Setting the transmission channel

When necessary, it is possible to change the transmission channel from channel 1 to another channel. Use the following procedure for this function.

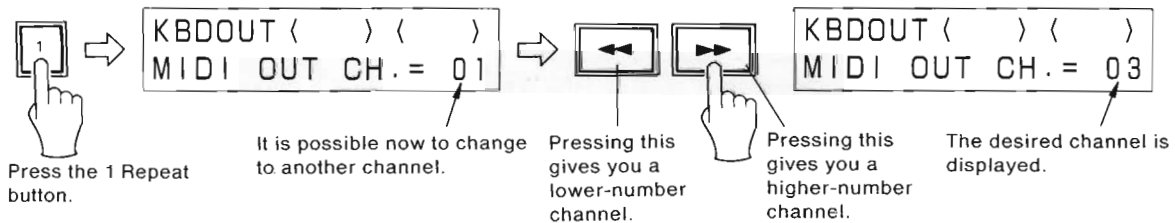

* When using this function during playback, after you finish setting the channel, please cancel MIDI Setup Mode. However, this function will not operate unless "DELAY OUT/KEYBOARD OUT" is set to KEYBOARD OUT.

⑤ Setting the reception channel for the external instrument

Set the reception channel for the external instrument so that it matches the transmission channel of the Disklavier.

⑥ Performance

Try performing something. The following functions can be used as necessary:

• Setting the split function

When necessary, transmission of the upper and lower ranges of the keyboard is possible on different channels. (One is output through the specified transmission channel and the other is output through the next highest channel.) Use the following procedure for this function:

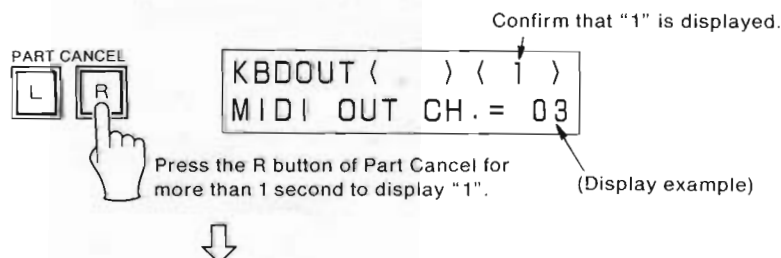

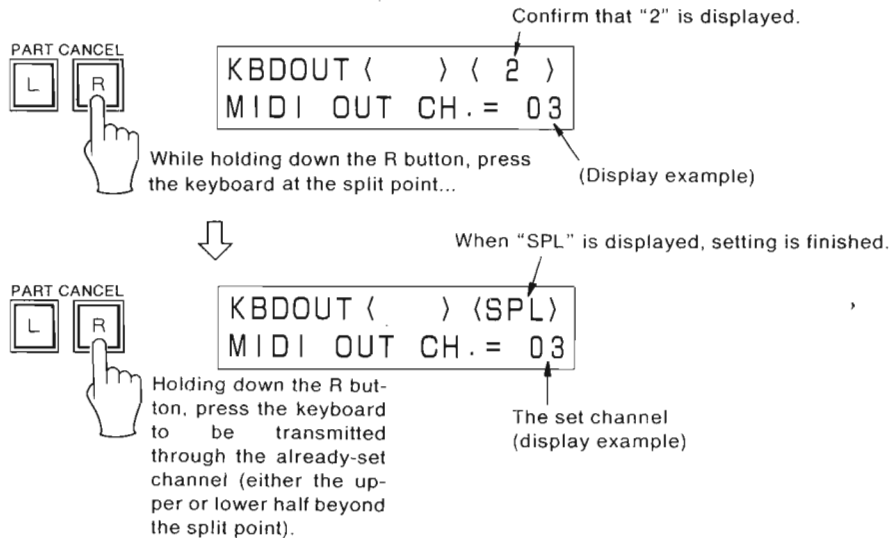

- * When using this function during playback, after setting, please cancel the MIDI Setup Mode. However, this function will not operate unless "DELAY OUT/KEYBOARD OUT" is set to KEYBOARD OUT.
- * If another instrument is connected through the MIDI THRU terminal, its upper and lower keyboard sections can correspond to those already set. Set the respective reception channels to match.
- * To turn off the split function, press the R button of Part Cancel. (During playback, this cannot be set to off unless you are in MIDI Setup Mode.)

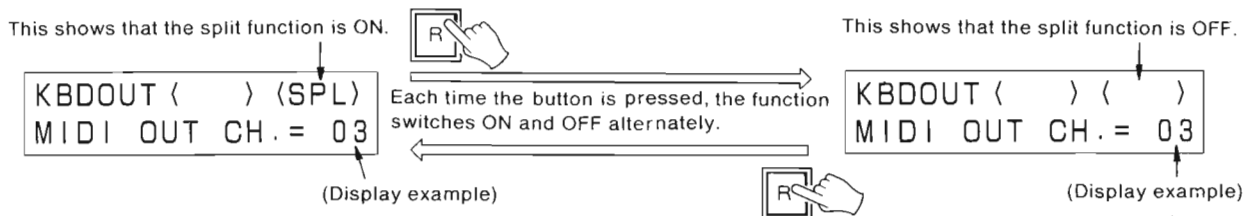

● External Instrument Transposition

When necessary, the information sent to an external instrument can be transposed within a range of ± 5 octaves. However, information cannot be output that extends beyond the keyboard range of the piano. Use the following procedure for this function:

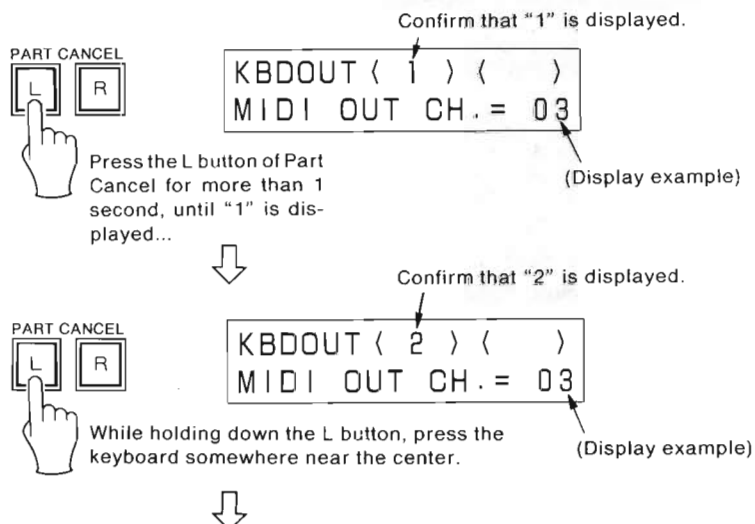

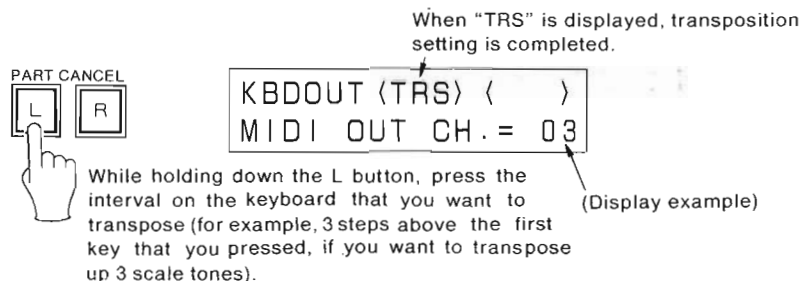

- * When using this function during playback, after setting, please cancel MIDI Setup Mode. However, this function will not operate unless "DELAY OUT/KEYBOARD OUT" is set to KEYBOARD OUT.
- * To turn off the transposition, press the L button of Part Cancel. (During playback, the function cannot be turned off unless you are in MIDI Setup Mode.)

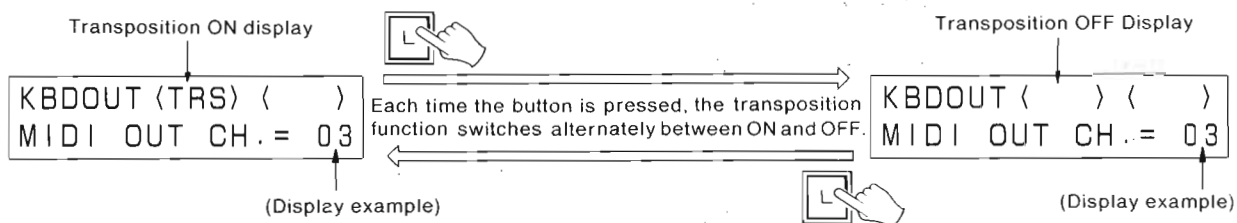

● Volume Adjustment of External Instrument

When necessary, the volume of the external instrument can be adjusted. Use the following procedure for this function:

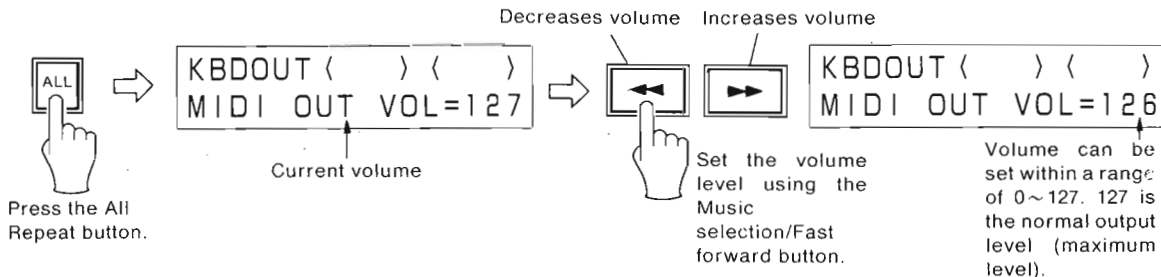

- * When using this function during playback, after setting, please cancel MIDI Setup Mode. This function will operate even when "DELAY OUT/KEYBOARD OUT" is set to DELAY OUT:

● Changing the Voicing of the External Instrument

When necessary, the voicing of the external instrument can be changed at the Disklavier. Use the following procedure for this function.

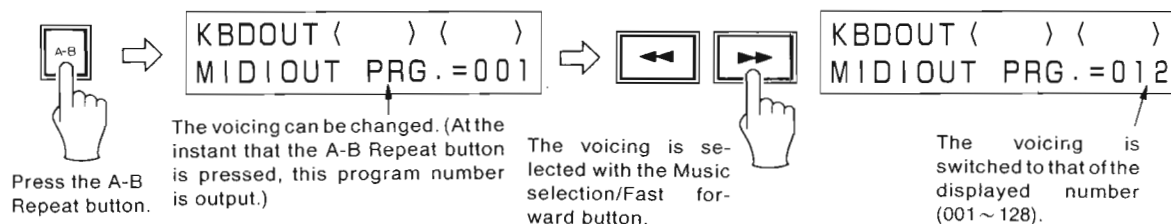

- * When using this function during playback, after switching the voicing, please cancel MIDI Setup Mode. This function will operate even when "DELAY OUT/KEYBOARD OUT" is set to DELAY OUT.

Switching DELAY OUT/KEYBOARD OUT

When switching between DELAY OUT and KEYBOARD OUT, the content of the information transmitted through the MIDI OUT terminal also changes.

- DELAY OUT** If switching is performed, this condition is entered. This is the normal condition for playing back a disk. The playback content of the floppy disk and the information received through the MIDI IN terminal are sent through the MIDI OUT terminal without any changes.

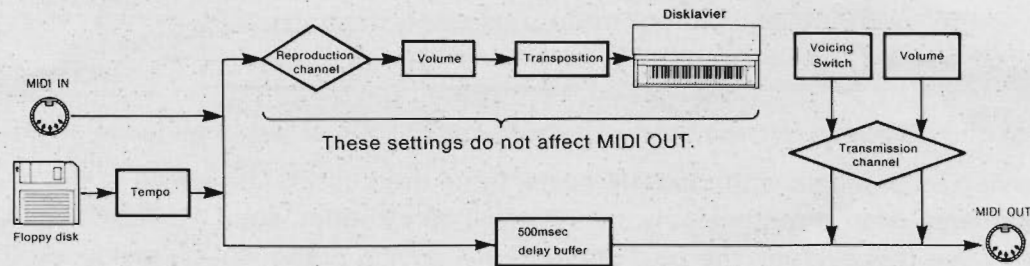

- KEYBOARD OUT** This is the condition for transmission of performance content, or for transmitting only part of piano playback. In other words, the information transmitted through MIDI OUT is the same as the content being produced through the piano.

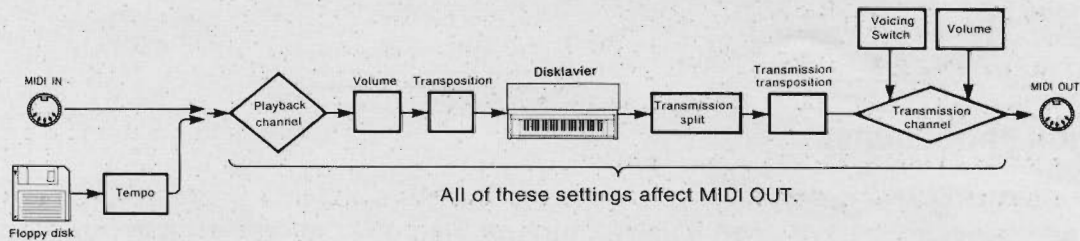

3-4. Using the Disklavier (Piano) when Playing Back from a Sequencer

When playing back contents stored in a sequencer, if the information is input through the MIDI IN terminal of the Disklavier, playback is possible on the piano.

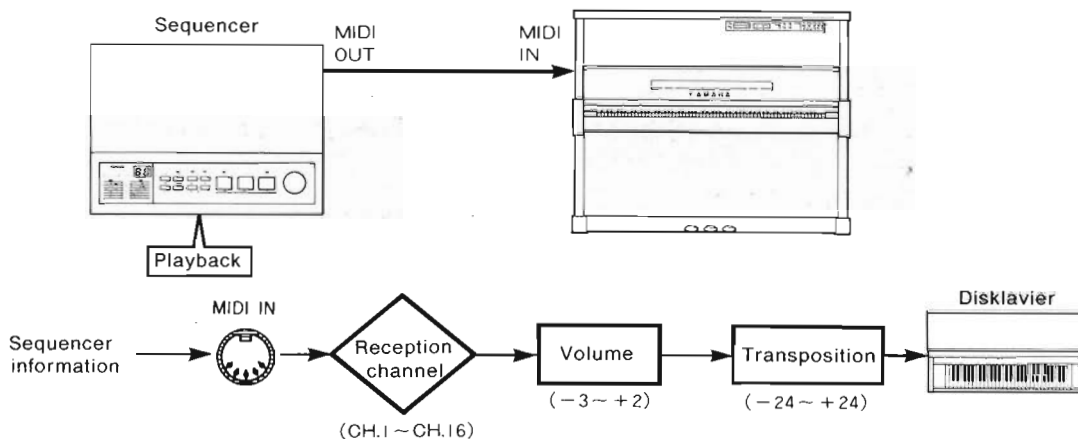

When playing back music with multiple parts, input the information for all of the parts at once to the Disklavier. After directing it via the 500msec delay buffer, send it to the other instruments. If you don't use this system, the part played back on the piano will be produced 0.5 seconds later than the other parts. (On the piano, it takes 0.5 seconds from the time the key information is received to the time the key is struck.)

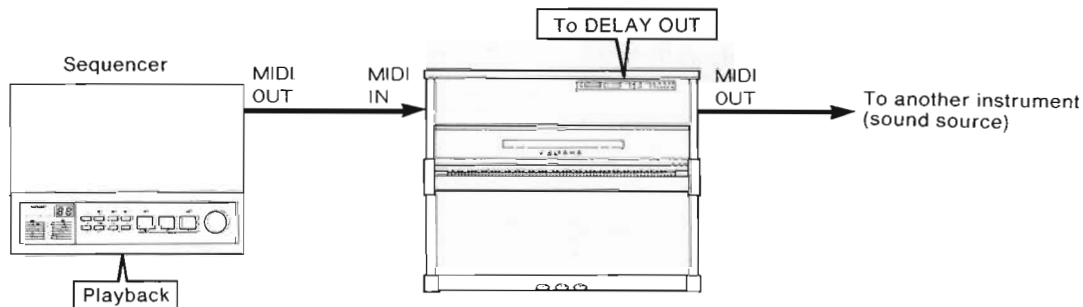

OPERATION PROCEDURES

① Preparation

When all connections have been finished, turn on the power and insert a floppy disk.

② Switch to MIDI Setup Mode

③ Set the Reception Channel

After pressing the Tempo button, the reception channel is set using either the key or the key. Set the reception channel to match the transmission channel of the sequencer.

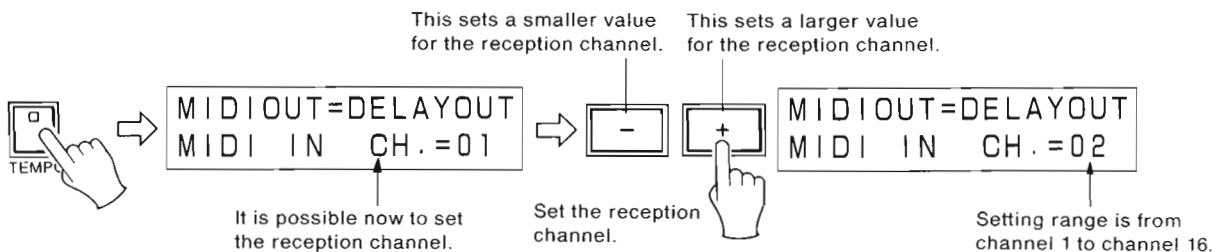

④ Starting Playback

Start the sequencer.

● **Volume adjustment**

The volume can be adjusted either in MIDI Setup Mode or under normal conditions. In MIDI Setup Mode, use the following procedure:

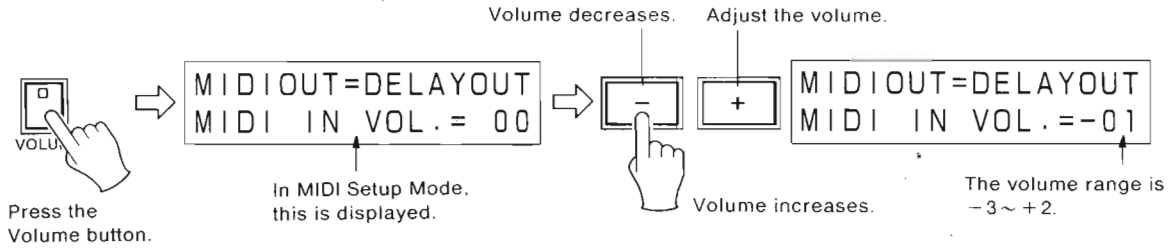

* The value set here is effective even when you return to the normal mode.

● **Transposition**

Transposition is possible either in MIDI Setup Mode or under normal conditions. In MIDI Setup Mode, use the following procedure:

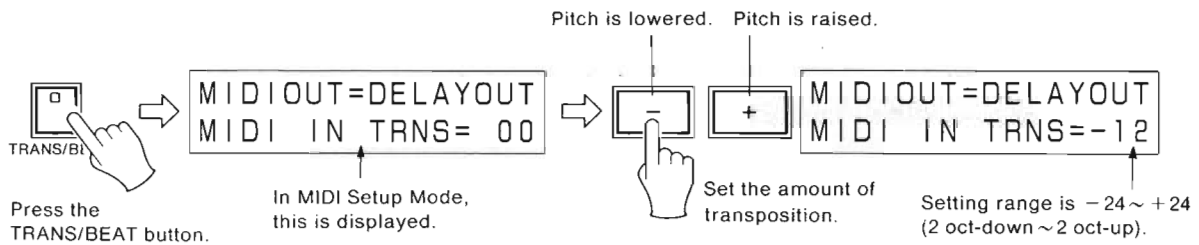

3-5. Storing Piano Performance Content in the Sequencer

Piano performance content can be stored, not only on the Disklavier floppy disk, but in the sequencer as well.

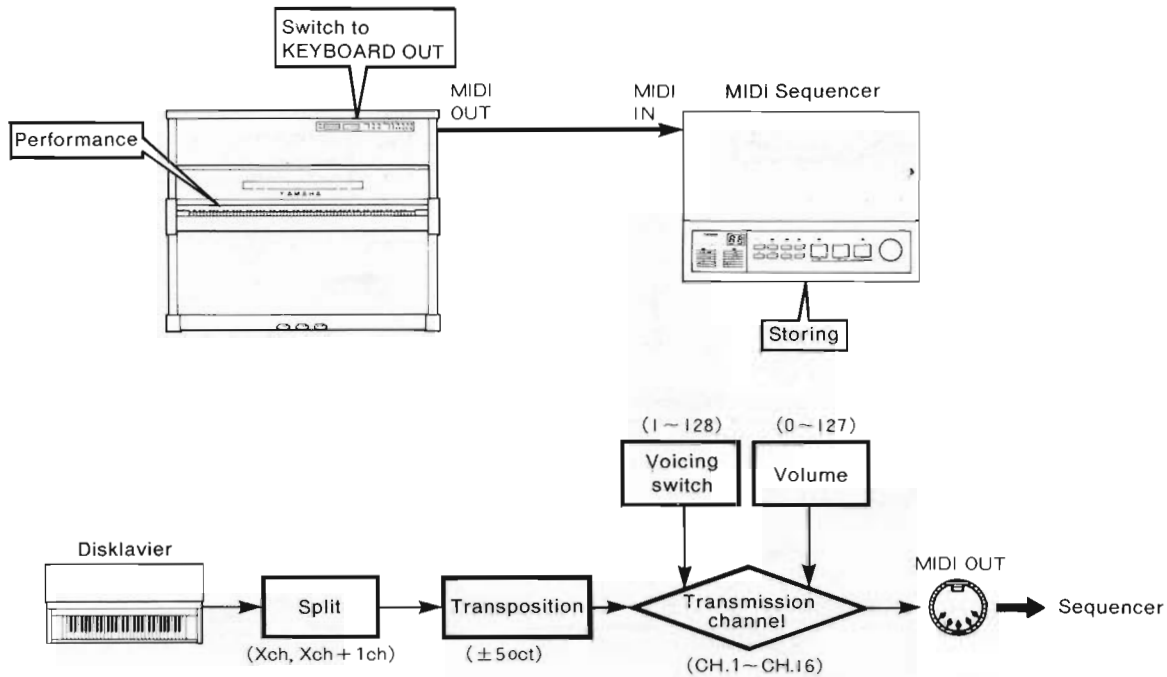

OPERATION PROCEDURES

① Preparation

When all connections have been finished, turn on the power and insert a floppy disk.

② Switch to MIDI Setup Mode.

③ Switch to KEYBOARD OUT.

Switch the "DELAY OUT/KEYBOARD OUT" to KEYBOARD OUT.

④ Set the transmission and reception channels.

Set the transmission channel of the Disklavier and the reception channel of the sequencer so they match.

⑤ Set each of the functions.

Set the split function and adjust the volume output level as necessary.

⑥ Enter Recording Standby mode

Put the sequencer in Recording Standby mode.

⑦ Start recording.

Press the sequencer's Start button, or use the metronome function of the Disklavier to make the sequencer start recording. Start performance.

If you change the voicing after recording has begun, the program change information will also be recorded.

3-6. Playback of Ensemble Music

When playing back ensemble music, if the playback contents are sent through the MIDI OUT terminal, it is possible to play back all of the parts.

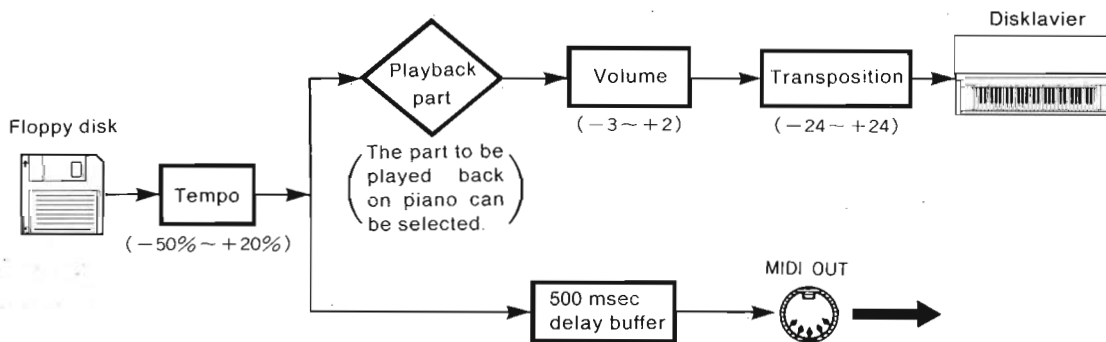
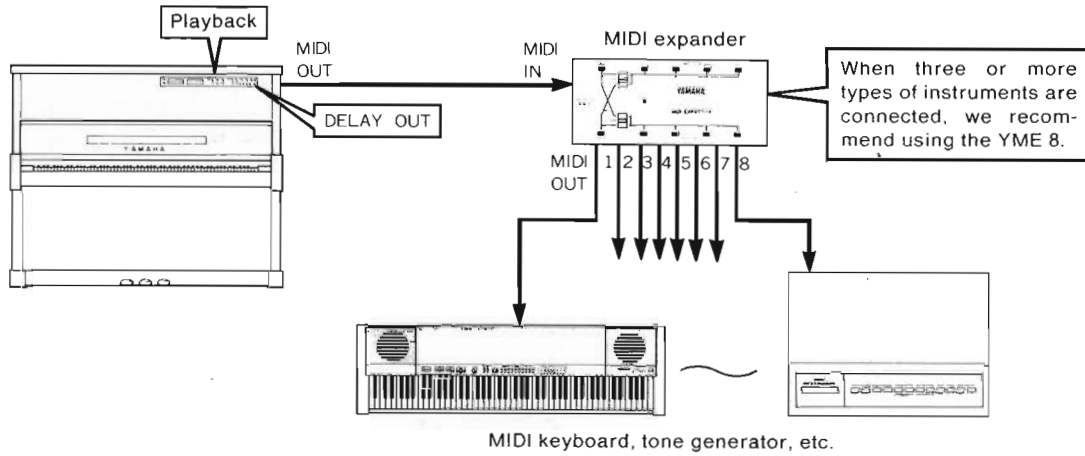

OPERATION PROCEDURE

① Preparation

When all connections have been finished, turn on the power and insert a floppy disk.

② Music selection

Select the ensemble music.

③ Playback part selection

Select the part to be played back by the piano.

④ Setting of each part

Decide the corresponding instrument for the information of each part, and set the reception channel for each one, along with the voicing.

⑤ Start playback

Press the Start/Pause button to start playback.

3-7. Data Compatibility

The Disklavier features compatibility with E-seq instruments. This means that disks recorded with the Disklavier can be played back on those instruments, and disks recorded with those instruments are playable on the Disklavier.

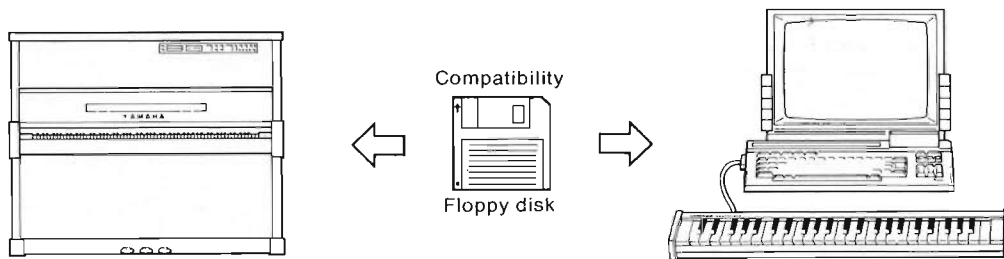

Compatible products that are currently on the market are QX3, the Yamaha MIDI recorder YRM-301 and the Yamaha FM Sound Synthesizer II-SFG-05.

- * The E-seq is a kind of MIDI sequencer meeting the Yamaha standard, that uses a 3.5-inch floppy disk.
- * When recording with a MIDI recorder, in the M mode, please record with Tempo set to 120.
- * To playback music recorded on other instruments on the Disklavier, it is necessary to perform "convert" operations. Music recorded on other instruments is converted as ensemble music.
- * To playback music recorded with the Disklavier on other instruments, please refer to the user's manual of that instrument.

3-8. Starting and Stopping the Rhythm Machine/Sequencer

Using the metronome function of the Disklavier, you can start and stop the rhythm machine and sequencer.

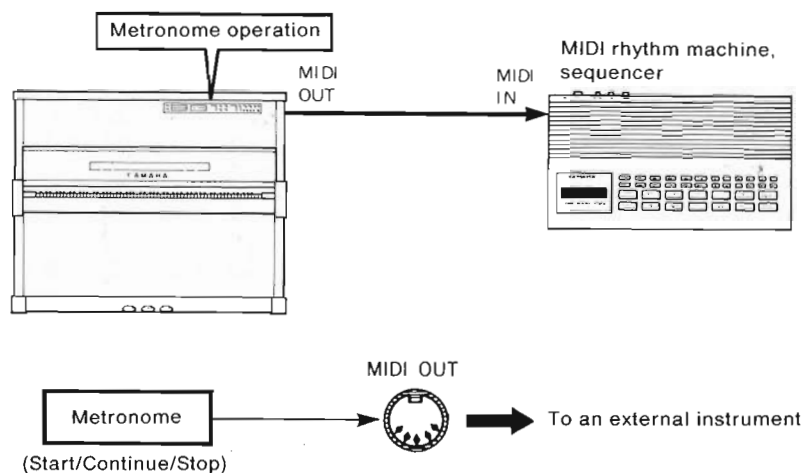

OPERATION PROCEDURE

① Preparation

When all connections have been finished, turn on the power and insert a floppy disk.

② Rhythm selection

Select the rhythm or music to be started/to be stopped.



③ Turning On the Metronome Function

After confirming that the Disklavier is in Stop mode, press the Metronome button to turn on the metronome function.

④ Metronome sound ON/OFF

After pressing the Volume button, turn off the metronome sound by pressing the  button.

⑤ Setting the rhythm tempo

The tempos of the rhythm machine and sequencer can be changed through the Disklavier as necessary. After pressing the Disklavier's Tempo button, set the tempo using the  and  buttons. At this time, set the synchronism of the rhythm machine and sequencer to external synchronism (CLOCK = MIDI, or CLOCK = EXTERNAL).

⑥ Starting the rhythm

When the Disklavier's Start/Stop button is pressed, the rhythm and music will start. Match your performance with the rhythm.

- To stop the rhythm, press the Stop button of the Disklavier.
- After starting the rhythm, each time the Start/Pause button is pressed, the rhythm and music will alternately pause and restart.

* This function can be used with no relation to the "DELAY OUT/KEYBOARD OUT" switch or "MIDI Channel" conditions. It can also be operated with the foot switch.

4. MIDI Data Format

4-1. Transmission Conditions

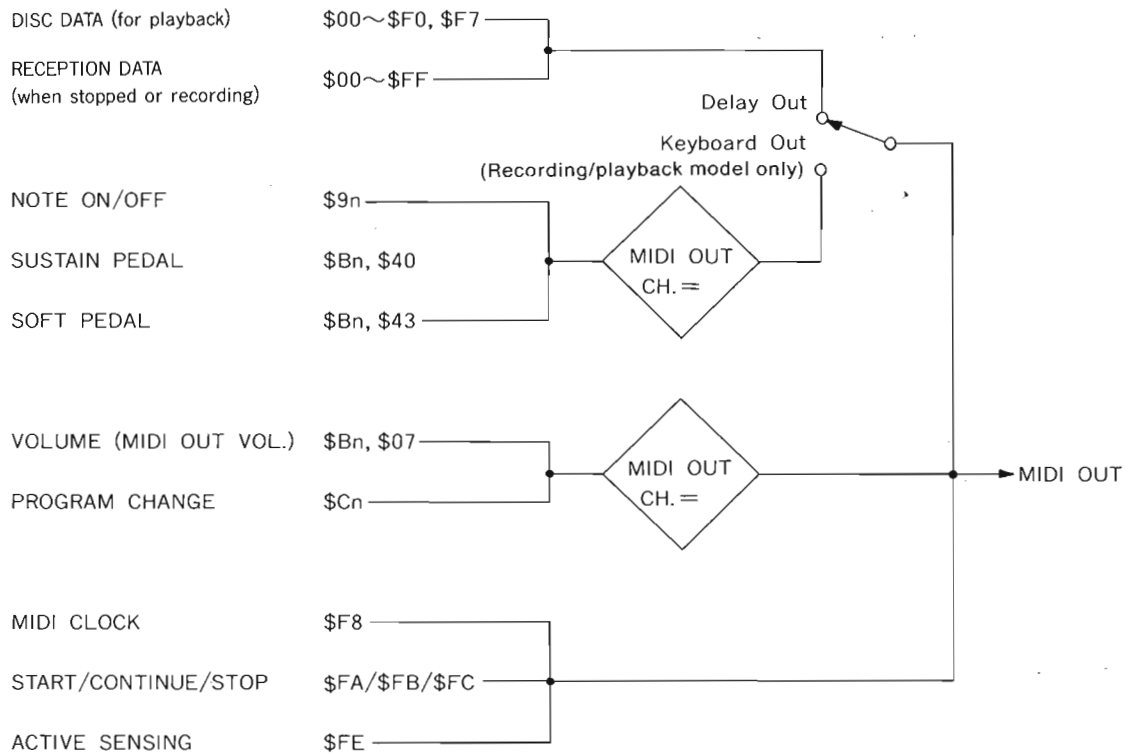

4-2. Transmission Data

• CHANNEL INFORMATION

1) CHANNEL VOICE MESSAGES

① Key On/Off

Status	1 0 0 1 n n n n (9n)	n = channel number (0~15)
Note No.	0 k k k k k k k	k = 21(A-1)~108 (C7): Note 1
Velocity	0 v v v v v v v	v = 0: key off v = 1~127: key on

Note 1: Transposition is also limited to this range.

② Control Change

Status	1 0 1 1 n n n n (Bn)	n = channel number (0~15)
Control No.	0 c c c c c c c	
Control value	0 v v v v v v v	

Control No.	Control value
c = 7 volume (MIDI OUT VOL.)	v = 0~127
c = 64 Sustain pedal	v = 0: off, 31: on
c = 67 Soft pedal	v = 0: off, 31: on

③ Program Change

Status	1 1 0 0 n n n n (Cn)	n = channel number (0~15)
Program No.	0 p p p p p p p	p = 0~127

• SYSTEM INFORMATION

1) SYSTEM REALTIME MESSAGES

① Timing clock

Status	1 1 1 1 1 0 0 0 (F8): Note 2
--------	------------------------------

Note 2: The clock tempo can be changed within a variable range of ♩ = 40~230.

② Start

Status	1 1 1 1 1 0 1 0 (FA)
--------	----------------------

③ Continue

Status	1 1 1 1 1 0 1 1 (FB)
--------	----------------------

④ Stop

Status	1 1 1 1 1 1 0 0 (FC)
--------	----------------------

⑤ Active sensing

Status	1 1 1 1 1 1 1 0 (FE): Note 3
--------	------------------------------

Note 3: When the preferred data, including active sensing, has been transmitted, if data is not transmitted within an interval of approximately 80 milli seconds, the main clock is transmitted.

- * The system realtime messages Timing Clock, Start, Continue, and Stop can be transmitted only when the metronome function is ON.
- * When playing back a disk recorded on another system (E-seq), all system information as well as system exclusive messages can be transmitted.
- * In MIDI OUT = DELAY OUT conditions, and also in Stop or Recording mode, delay the data received through MIDI IN by 500msec, and merge it with MIDI OUT without any changes.

4-3. Reception Conditions

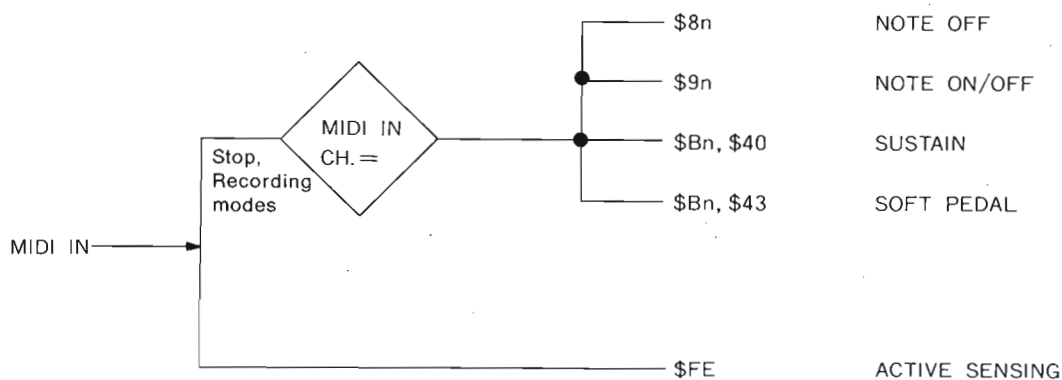

4-4. Reception Data

• CHANNEL INFORMATION

1) CHANNEL VOICE MESSAGES

① Key Off

Status	1 0 0 0 n n n n (8n)	n = channel number (0~15)
Note No.	0 k k k k k k k	k = 21 (A-1) ~ 108 (C7)
Velocity	0 v v v v v v v	v = ignored

② Key On/Off

Status	1 0 0 1 n n n n (9n)	n = channel number
Note No.	0 k k k k k k k	k = 21 (A-1) ~ 108 (C7)
Velocity	0 v v v v v v v	v = 0: key off v = 1 ~ 127: key on

③ Control Change

Status	1 0 1 1 n n n n (Bn)	n = channel number (0~15)
Control No.	0 c c c c c c c	
Control Value	0 v v v v v v v	
Control No.		Control Value
c = 64 Sustain pedal		v = 0: off, 31: on
c = 67 Soft pedal		v = 0: off, 31: on

• SYSTEM INFORMATION

1) SYSTEM REALTIME MESSAGES

① Active Sensing

Status	1 1 1 1 1 1 1 0 (FE): Note 4
--------	------------------------------

Note 4: When this code is received, sensing begins. If there is neither status nor data for an interval of 300msec, the piano keyboard and pedals become OFF, as do the Note ON of MIDI OUT and the Sustain Pedal ON.

4-5. MIDI Implementation Chart

[DISKLAVIER] Date :2/4,1986
 Model MX100A MIDI Implementation Chart Version :1.0

Function ...	Transmitted	Recognized	Remarks
:Basic Default	: 1	: 1	:
:Channel Changed	: 1 - 16	: 1 - 16	:
:Default	: 3	: 3	:
:Mode Messages	: x	: x	:
:Altered	: *****	: x	:
:Note	: 21 - 108	*1: 21 - 108	:
:Number : True voice	: *****	: 21 - 108	:
:Velocity Note ON	: o 9nH,v=1-127	: o v=1-127	:
:Note OFF	: x 9nH,v=0	*1: x	:
:After Key's	: x	: x	:
:Touch Ch's	: x	*1: x	:
:Pitch Bender	: x	*1: x	:
:Control	: 7 : o	: x	:
	: 64 : o	: o	:
	: 67 : o	: o	:
:Change	:	:	:
	:	*1:	:
	:	:	:
	:	:	:
	:	:	:
	:	:	:
	:	:	:
	:	:	:
:Prog	: o 0 - 127	*1: x	:
:Change : True #	: *****	:	:
:System Exclusive	: x	*1: x	:
:System : Song Pos	: x	: x	:
: : Song Sel	: x	: x	:
:Common : -Tune	: x	: x	:
:System :Clock	: o	: x	:if Metronome is
:Real Time :Commands	: o	: x	: used
:Aux :Local ON/OFF	: x	: x	:
: :All Notes OFF	: x	: x	:
:Mes- :Active Sense	: o	: o	:
:sages:Reset	: x	: x	:
:Notes: All recognized data are transmitted 500msec later			
: if controler mode is STOP or RECORD and DELAYOUT mode is on.			
:			
: *1 = All data are enabled to transmitted as record data			
: if other E_seq disk is used and DELAYOUT mode is on.			
:			
Mode 1 : OMNI ON, POLY	Mode 2 : OMNI ON, MONO	o : Yes	
Mode 3 : OMNI OFF, POLY	Mode 4 : OMNI OFF, MONO	x : No	

5. MIDI Troubleshooting and Know-how

When MIDI is connected, there are a few mistakes and problems that occur frequently.

- ① **A sound source instrument has been connected to the MIDI OUT terminal, but no sound is produced by the external instrument.**
 - Are you sure the MIDI cable is firmly connected between the MIDI OUT terminal of the Disklavier and the MIDI IN of the external instrument?
 - Does the reception channel of the external instrument match the transmission channel of the Disklavier?
 - If you are performing, is the MIDI OUT switched to KEYBOARD OUT?
 - During playback, is the MIDI OUT switched to DELAY OUT? (In this case, the transmission channel of the Disklavier cannot be changed.) Or, if it is KEYBOARD OUT, is the volume setting of the MIDI OUT VOL. or the piano volume too low?
- ② **A keyboard or sequencer is connected to the MIDI IN terminal, and performance took place on the external instrument, but the piano keys were not struck.**
 - Is the MIDI cable firmly connected between the MIDI OUT terminal of the external instrument and the MIDI IN of the Disklavier?
 - Is the power on, and has a floppy disk been inserted?
 - Does the reception channel of the Disklavier match the transmission channel of the external instrument?
 - Is the volume setting of the piano (MIDI IN VOL.) too low?
- ③ **A keyboard or sequencer is connected to the MIDI IN terminal of the Disklavier, and performance took place on the external instrument, but the piano keys were struck with delay.**
 - It takes about 0.5 seconds from the time the information is received until the time the piano keys are struck.
- ④ **There is a difference in pitch between the piano and the external instrument.**
 - Is the transposition function on?
 - Is the TRANS/BEAT set to something other than "normal"?
- ⑤ **The voicing of the external instrument can not be changed.**
 - Does the transmission channel of the Disklavier match the reception signal of the external instrument? (If they do not match, the voicing cannot be changed.)
- ⑥ **The MIDI OUT VOL. function does not operate for the external instrument.**
 - Does the transmission channel of the Disklavier match the reception channel of the external instrument? (If they do not match, switching is not possible.)
- ⑦ **During performance or playback on the piano, there is no problem with the piano, but the upper or lower tones are not produced on another keyboard.**
 - Are you playing music separated for left and right hand?
 - Is the split function on?

-
- ⑧ **Split, transposition functions do not work on the external instrument.**
- Is the MIDI OUT set to DELAY OUT? (If it is not set to KEYBOARD OUT, these functions will not operate.)
 - Does the transmission channel of the Disklavier match the reception channel of the external instrument?
- ⑨ **When playing ensemble music, the external instrument receives all parts.**
- Is the reception channel of the external instrument set to OMNI ON?
- ⑩ **The MIDI OUT CH. was specified, but information is not output through the specified channel.**
- Is the MIDI OUT set to DELAY OUT? (If the performance information transmission channel was set to KEYBOARD OUT only, you can change to the original channel and transmit.)
- ⑪ **Voicing data was dumped from the keyboard or other instrument connected to the MIDI IN terminal of the Disklavier to the keyboard or instrument connected to the MIDI OUT terminal of the Disklavier, but on the Disklavier, "MIDI DATA ERROR" is displayed and the command is not implemented.**
- If a large volume of data is transmitted, dump without sending the data via the Disklavier.
- ⑫ **You recorded ensemble music yourself, but when you play it back, the rhythm goes haywire.**
- Sometimes if the amount of data is too large, the rhythm goes haywire.
To protect the piano, avoid sending overly large amounts of data. Also, avoid entering quick repeated notes or successive or long scores as much as possible.
- ⑬ **The piano repeats the same note over and over.**
- Is there a loop in the wiring of the MIDI cable?
- ⑭ **Playback is started on the Disklavier, and you wanted to start the rhythm machine and sequencer simultaneously by using system realtime messages, but cannot start them.**
- Timing Clock, Start, Continue, and Stop can be transmitted only in Stop or Recording mode, when the metronome function is ON.

6. Block Diagram

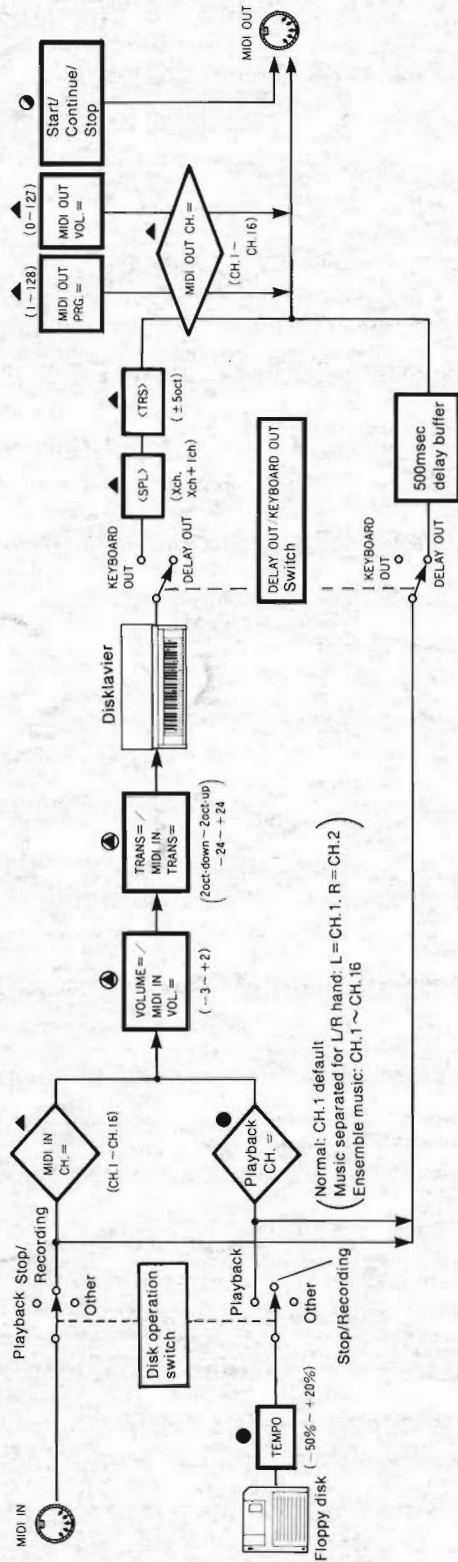

* This block diagram shows the MIDI functions in block form.

- ◐ : Can be set in normal mode or MIDI Setup Mode.
- ◑ : Can be set in normal mode.
- ◒ : Can be set in MIDI Setup Mode.
- ◓ : Produced during metronome operation.

MX100A // MX100B Disklavier Piano

Unpublished Functions

TEST PROGRAM MODE

Turn on the power switch with both the [L] and [R] buttons depressed to enter TEST PROGRAM mode.

MIDI DATA RECORDER (MDR) MODE

Turn on the power switch with [VOL] [TEMPO] and [TRANS] buttons depressed to enter MIDI DATA RECORDER mode.

You can store data being received MIDI IN directly to the floppy in this mode. You cannot use it to record data from the Disklavier piano directly.

All songs recorded in this mode are treated as Ensemble song.

MIDI OUT DELAY TIME CONTROL MODE

While in MIDI mode and with "MIDIOUT=DELAYOUT" displayed, you can enter DELAY TIME CONTROL mode by depressing [START/PAUSE] and [STOP] for a few seconds.

LCD will display "DELAY TIME=500ms"

You can change the DELAY TIME with the [STOP] and [START/PAUSE] buttons.

[STOP] button — increment by 4msec step
[START/PAUSE] button — decrement by 4msec step

The adjustable range is 0 — 700msec.

TO PLAY TWO DISKLAVIER PIANOS SIMULTANEOUSLY - Set "DELAY TIME = 000msec" on the "master" Disklavier (the one playing the disk.) Connect one end of a MIDI cable to the MIDI OUT port of the "master" Disklavier and the other end to the MIDI IN port of the second Disklavier.

REALTIME MIDI-IN MODE

Power up with the [MIDI] key depressed. Continue depressing the [MIDI] key until LCD displays "MIDIOUT=DELAYOUT". (For this mode, inserting a disk into the disk drive is not necessary.)

Release the [MIDI] key and press the [METRONOME] key. The LED on the [METRONOME] key will light — the LCD display will not change. You are now in REALTIME MIDI-IN mode.

To exit this mode, turn the power off.

MIDI-IN DELAY SCHEDULE:	MIDI VELOCITY	ON	OFF
	01	212ms	64ms
	10	212	64
	20	212	64
	28	152	64
	30	68	40
	40	44	36
	7F	32	32

NOTE: To quickly determine whether or not the ROM version installed has this capability, try powering up with the [MIDI] key depressed with no disk in the disk drive. If LCD displays "INSERT DISK" only, you will need to exchange the existing ROM. Only ROM versions V1.30A880514 or V1.4A881119 (or later) will allow MIDI-IN REALTIME capability.